

Agenda



Regular Board Meeting of the Board of Directors

Meeting Location:

**Basin Transit Operations Center
62405 Verbena Road
Joshua Tree, CA 92252**

It is the intention of Basin Transit to comply with the Americans with Disabilities Act in all respects. If you have a disability and need accommodation to participate in the meeting, please call the Assistant Board Secretary at 760-366-2986 or email michal@basin-transit.com for assistance so the necessary arrangements can be made.

Public comments may be submitted via email to the Assistant Board Secretary at michal@basin-transit.com prior to November 20, 2024, at 5:00 PM with your name, telephone number, and subject of your public comment (agenda item or non-agenda item). If you send written comments, your comments will be made part of the official record of the proceedings and read into the record if they are received by the deadline above.

Board of Directors

Jeff Drozd, Chair
Daniel L. Mintz, Sr., Vice Chair
Merl Abel
Jennifer Henning
Dawn Rowe (Danielle Harrington Designee)
William Sasnett, Jr.
McArthur Wright

Officers

Cheri Holsclaw, Board Secretary
Michal Brock, Assistant Board Secretary



REGULAR MEETING OF THE BOARD OF DIRECTORS

AGENDA

Thursday, November 21, 2024
62405 Verbena Road, Joshua Tree CA 92252
5:00 PM

1.0 CALL TO ORDER

PLEDGE OF ALLEGIANCE

ROLL CALL: Board Members: Abel, Harrington, Henning, Mintz, Sasnett, Wright and Chair Drozd

2.0 SPECIAL RECOGNITIONS AND PRESENTATIONS

2.1 Employee of the Quarter

3.0 PUBLIC COMMENTS

3.1 This is a time for comments from the public on any subject not on the agenda. The Brown Act prohibits the Basin Transit Board of Directors from responding at length to questions on matters not on the agenda. Matters may, however, be referred to staff for scheduling on a future agenda. Comment time is limited to three minutes.

3.2 Public comments on specific agenda items will be deferred until consideration of the item on the agenda. Comment time is limited to three minutes.

4.0 CONSENT CALENDAR—All matters listed under the Consent Calendar are to be considered routine by the Basin Transit Board and will be enacted by one motion in the form listed. Any item may be removed from the Consent Calendar and considered separately by the Board under item 6.0 on the agenda. The public may comment on Consent Calendar items prior to Board action (roll call vote).

4.1 [Minutes of the September 26, 2024 Board Meeting](#)
Staff Recommendation: Approve Minutes

4.2 [Treasurer's Report for August and September 2024](#)
Staff Recommendation: Approve Treasurer's Reports

4.3 [Warrant Register through September 30, 2024](#)
Staff Recommendation: Approve Warrant Register

- 4.4 [Ridership Reports](#)
Staff Recommendation: Receive and File
- 4.5 [Financial Reports](#)
Staff Recommendation: Receive and File
- 4.6 [Taxi Report](#)
Staff Recommendation: Receive and File
- 4.7 [General Manager's Reports](#)
Staff Recommendation: Receive and File
- 4.8 [Operations Report](#)
Staff Recommendation: Receive and File
- 4.9 [Transit Operating, Capital Plan \(TOCP\) Reallocation](#)
Staff Recommendation: Approve TOCP Reallocation; Authorize Staff to File Transit Claim
- 4.10 [End-of-Year Employee Recognition](#)
Staff Recommendation: Approve \$100 end-of-year recognition to each Basin Transit employee

ACTION: Move _____ 2nd _____ Roll Call Vote

5.0 ITEMS REMOVED FROM CONSENT CALENDAR FOR DISCUSSION AND/OR PARTICIPATION AND/OR ADDED AGENDA ITEMS

6.0 OLD BUSINESS

NONE

7.0 NEW BUSINESS

- 7.1 [Short Range Transit Plan](#)
Staff Recommendation: Discuss as Necessary
- 7.2 [35-Year Anniversary Update](#)
Staff Recommendation: Discuss as Necessary
- 7.3 [Bus Stop Improvement IFB #24-01](#)
Staff Recommendation: Approve IFB #24-01, Bus Turnout and Shelter; Authorize Staff to Award Project to Lowest Responsive Bidder

ACTION: Move _____ 2nd _____ Roll Call Vote

7.4 [Clean Energy Amended Agreement](#)

Staff Recommendation: Authorize General Manager to Execute Clean Energy Amended Agreement

ACTION: Move _____ 2nd _____ Roll Call Vote

8.0 CLOSED SESSION

NONE

9.0 GENERAL MANAGER UPDATE

10.0 FUTURE BOARD INITIATED AGENDA ITEMS

11.0 BOARD MEMBER COMMENTS - This is the time for comments from the Board members on any subject.

12.0 ADJOURNMENT - The next regularly scheduled board meeting will be held on Thursday, January 23, 2025, at 5:00 PM at the Basin Transit Operations Center, 62405 Verbena Road, Joshua Tree CA 92252.

All items appearing on this Agenda, whether or not expressly listed for action, may be deliberated and may be subject to action by the Board. **This agenda is certified to have been posted on or before November 18, 2024, at 5:00 PM.**



Michal Brock, Assistant Board Secretary

11/18/2024
Date

BASIN TRANSIT

TO: Board of Directors

FROM: Cheri Holsclaw, General Manager

DATE: November 21, 2024

RE: Minutes of the September 26, 2024 Board Meeting

STAFF RECOMMENDATION: APPROVE MINUTES

ITEM 4.1

BASIN TRANSIT

**REGULAR MEETING OF
THE BOARD OF DIRECTORS**

Thursday, September 26, 2024 5:00 p.m.
Basin Transit Operations Center
62405 Verbena Road
Joshua Tree, CA 92252

ACTION MINUTES

1.0 CALL TO ORDER – Chair Drozd called the meeting to order at 5:00 p.m.

PLEDGE OF ALLEGIANCE – Sara Hudson

ROLL CALL

Members Present:

Jeff Drozd
Jennifer Henning
Ben Sasnett

Danielle Harrington
Dan Mintz
McArthur Wright

Members Absent:

Merl Abel

2.0 SPECIAL RECOGNITIONS AND PRESENTATIONS

NONE

3.0 PUBLIC COMMENTS

NONE

4.0 CONSENT CALENDAR

4.1 Minutes of the July 25, 2024 Board Meeting

4.2 Treasurer's Report for June 2024 and July 2024

4.3 Warrant Register through July 31, 2024

4.4 Ridership Reports

4.5 Financial Reports

4.6 Taxi Report

4.7 General Manager's Report(s)

4.8 Operations Report

4.9 Drug & Alcohol Policy Update

ACTION: Vice Chair Mintz moved to approve the Consent Calendar (items 4.1 - 4.9); seconded by Board Member Wright: motion passed by Roll Call Vote (6-0).

5.0 ITEMS REMOVED FROM CONSENT CALENDAR FOR DISCUSSION AND/OR PARTICIPATION AND/OR ADDED AGENDA ITEMS

NONE

6.0 OLD BUSINESS

NONE

7.0 NEW BUSINESS

7.1 Approve Transportation Assistance Grant (TAG) Awards

The following TAG award applicants expressed their gratitude to the Board for considering their projects for grant awards:

Linda Murphy, Pacific Clinics
Robin Schlosser, Reach Out Morongo Basin
Astrid Johnson, Morongo Basin Arch
Sandy Smith, Copper Mountain College Foundation
Benita Brown, The Way Station

Joe Meer requested that the Board revise the TAG budget and approve TAG awards as listed in the staff report.

ACTION: Vice Chair Mintz moved to revise the TAG budget and approve TAG awards as listed in the staff report; seconded by Board Member Henning: motion passed by Roll Call Vote (6-0).

After the vote Chair Drozd thanked the grant recipients for all they do for the Morongo Basin and Board Member Sasnett commented that the TAG awarding vote is his favorite meeting of the year.

7.2 Short Range Transit Plan (SRTP) Discussion

Cheri introduced the SRTP consulting staff to the Board and handed over the floor to Manuel Soto of Jarrett Walker & Associates who gave a presentation and

discussed the SRTP's concepts, purposes, and development processes with the Board.

7.3 Heat Illness Prevention Plan

Cheri Holsclaw provided a brief oral report and requested that the Board adopt Basin Transit's Heat Illness Prevention Plan.

ACTION: Board Member Wright moved to approve Basin Transit's Heat Illness Prevention Plan; seconded by Board Member Harrington, motion passed by Roll Call Vote (6-0).

7.4 Safety Procedures of Sharp Objects

Cheri Holsclaw explained the purpose of the newly developed safety procedures for disposing of sharp objects and requested that the Board adopt them.

ACTION: Board Member Sasnett moved to adopt Basin Transit's safety procedures for the disposal of sharp objects; seconded by Board Member Wright, motion passed by Roll Call Vote (6-0).

8.0 CLOSED SESSION

NONE

9.0 GENERAL MANAGER UPDATE

Cheri thanked the Marketing Committee (Chair Drozd and Board Member Henning) for meeting the previous week to discuss Basin Transit's marketing activities. Cheri also shared that the Committee decided to cut the logo out of the jackets that the vendor incorrectly sent in the wrong color. A patch will be placed over the cut out and donated locally to those in need. Before moving forward with that project, Cheri offered a jacket to each of them.

10.0 FUTURE BOARD INITIATED AGENDA ITEMS

NONE

11.0 BOARD MEMBER COMMENTS

The following Board Members made comments:

Vice Chair Mintz

Board Member Sasnett

Board Member Wright

12.0 ADJOURNMENT

The meeting adjourned at 5:57 p.m. Thursday, September 26, 2024.

Respectfully submitted,

A handwritten signature in black ink, appearing to read 'Michal Brock', written over a horizontal line.

Michal Brock, Assistant Board Secretary

BASIN TRANSIT

TO: Board of Directors

FROM: Cheri Holsclaw, General Manager

DATE: November 21, 2024

RE: Treasurer's Reports for August 2024 and September 2024

STAFF RECOMMENDATION: APPROVE TREASURER'S REPORTS

BASIN TRANSIT
TREASURER'S REPORT
August 31, 2024

Beginning Balance:	July 31, 2024	8,107,806
Receipts		1,610,159
Disbursements		955,915
Interest Received		136
Ending Balance:	August 31, 2024	<u>8,762,186</u>

LOCATION OF FUNDS:	BALANCE	INTEREST EARNED	INTEREST RATE
US Bank General	\$ 60,707	-	0.00%
US Bank Class E	\$ - \$	-	0.00%
Pacific Western Bank Procurement Fees	\$ 1,521,937 \$	-	0.00%
US Bank MAIN	\$ 2,802,597 \$	-	0.00%
Pacific Western Bank	\$ 201,191 \$	-	0.00%
LAIF	\$ 3,455,203 \$	-	0.00%
US Bank PTMISEA	\$ 238,569 \$	-	0.00%
US Bank LCTOP	\$ 343,754 \$	-	0.00%
US Bank SGR (SB1)	\$ 138,227 \$	-	0.00%
	\$	-	0.00%
TOTAL INVESTMENTS	\$ 8,762,186	\$ -	

BASIN TRANSIT
TREASURER'S REPORT
September 30, 2024

Beginning Balance:	August 31, 2024	8,762,186
Receipts		441,716
Disbursements		764,731
Interest Received		262
Ending Balance:	September 30, 2024	<u>8,439,433</u>

LOCATION OF FUNDS:	BALANCE	INTEREST EARNED	INTEREST RATE
US Bank General	\$ 60,621	-	0.00%
US Bank Class E	\$ - \$	-	0.00%
Pacific Western Bank Procurement Fees	\$ 1,541,479 \$	-	0.00%
US Bank MAIN	\$ 2,558,251 \$	-	0.00%
Pacific Western Bank	\$ 152,489 \$	-	0.00%
LAIF	\$ 3,455,203 \$	-	0.00%
US Bank PTMISEA	\$ 238,573 \$	-	0.00%
US Bank LCTOP	\$ 343,780 \$	-	0.00%
US Bank SGR (SB1)	\$ 89,037 \$	-	0.00%
	\$	-	0.00%
TOTAL INVESTMENTS	\$ 8,439,433	\$ -	

BASIN TRANSIT

TO: Board of Directors

FROM: Cheri Holsclaw, General Manager

DATE: November 21, 2024

RE: Warrant Register through September 30, 2024

STAFF RECOMMENDATION: APPROVE WARRANT REGISTER

**BASIN TRANSIT
WARRANT REGISTER
As of August 31, 2024**

<u>Date</u>	<u>Name</u>	<u>Memo</u>	<u>Paid Amount</u>
08/01/2024	BURRTEC	UTILITIES	-85.16
08/01/2024	BURRTEC	UTILITIES	-223.25
08/01/2024	JOE MEER	TRAININGS/MEETINGS	-449.47
08/01/2024	US BANK	CREDIT CARD PYMNT	-3,968.24
08/01/2024	CLEAN ENERGY	CNG MAINTENANCE	-5,338.83
08/01/2024	DIAMOND ENVIRONMENTAL SERVICES	UTILITIES	-122.87
08/01/2024	FRONTIER COMMUNICATIONS	TELEPHONE	-608.16
08/01/2024	GILLIG LLC	PARTS	-547.86
08/01/2024	GOVERNMENT FINANCE OFFICERS ASSOCIATION	TRAININGS/MEETINGS	-135.00
08/01/2024	MODEL 1 COMMERCIAL VEHICLES, INC.	PARTS	-1,990.23
08/01/2024	PRUDENTIAL OVERALL SUPPLY	UNIFORMS & FACILITY SUPPLIES	-299.35
08/01/2024	ADP	OUTSIDE SERVICES	-208.35
08/01/2024	BURRTEC	UTILITIES	-245.97
08/02/2024	SPECTRUM	TELEPHONE	-134.99
08/02/2024	[EMPLOYEE]	WAGES	-2,892.68
08/02/2024	PACIFIC WESTERN BANK	IN DISPUTE	-18,900.00
08/03/2024	SENTINEL BENEFITS	OUTSIDE SERVICES	-25.00
08/05/2024	SOUTHERN CALIFORNIA EDISON	UTILITIES	-16,184.36
08/05/2024	ADP	OUTSIDE SERVICES	-597.94
08/05/2024	CALPERS HEALTH/RETIREMENT	HEALTH INSURAANCE	-27,517.77
08/06/2024	ARCO	FUEL	-276.68
08/09/2024	NOEMI ADDERLEY	SAFETY INCENTIVE PRGM	-100.00
08/09/2024	SYLVIA L ARAIZA	SAFETY INCENTIVE PRGM	-100.00
08/09/2024	ROBERT ARVIZU	SAFETY INCENTIVE PRGM	-100.00
08/09/2024	MATTHEW ATKINS	SAFETY INCENTIVE PRGM	-100.00
08/09/2024	PAULA BALDWIN	SAFETY INCENTIVE PRGM	-100.00
08/09/2024	KIMBERLY BERNARD	SAFETY INCENTIVE PRGM	-100.00
08/09/2024	ANDREW BERNSTEIN	SAFETY INCENTIVE PRGM	-100.00
08/09/2024	SHEMIKA BORTEE	SAFETY INCENTIVE PRGM	-100.00
08/09/2024	DAWN BOSTROM	SAFETY INCENTIVE PRGM	-100.00
08/09/2024	MICHAL BROCK	SAFETY INCENTIVE PRGM	-100.00
08/09/2024	GARY COOPER	SAFETY INCENTIVE PRGM	-100.00
08/09/2024	BLAS CRUZ	SAFETY INCENTIVE PRGM	-100.00
08/09/2024	ROY DAVIS	SAFETY INCENTIVE PRGM	-100.00
08/09/2024	CORY DOUGLASS	SAFETY INCENTIVE PRGM	-100.00
08/09/2024	PATRICK FERREE	SAFETY INCENTIVE PRGM	-100.00
08/09/2024	SABRINA FRANKLIN	SAFETY INCENTIVE PRGM	-100.00
08/09/2024	SYMON GARCIA	SAFETY INCENTIVE PRGM	-100.00
08/09/2024	JOSE GIRON	SAFETY INCENTIVE PRGM	-100.00
08/09/2024	CHRISTINA GUTIERREZ	SAFETY INCENTIVE PRGM	-100.00
08/09/2024	GEORGE HALLAS	SAFETY INCENTIVE PRGM	-100.00
08/09/2024	THOMAS HATHAWAY	SAFETY INCENTIVE PRGM	-100.00
08/09/2024	CHERI HOLSCRAW	SAFETY INCENTIVE PRGM	-100.00
08/09/2024	DOUG HUNTER	SAFETY INCENTIVE PRGM	-100.00

BASIN TRANSIT
WARRANT REGISTER
As of August 31, 2024

08/09/2024	GARY JOHNSON	SAFETY INCENTIVE PRGM	-100.00
08/09/2024	LYDIA KNUDSON	SAFETY INCENTIVE PRGM	-100.00
08/09/2024	CYNTHIA LOPEZ	SAFETY INCENTIVE PRGM	-100.00
08/09/2024	NICHOLAS LUTRELL	SAFETY INCENTIVE PRGM	-100.00
08/09/2024	HECTOR MANZANO	SAFETY INCENTIVE PRGM	-100.00
08/09/2024	ADAH MARTINEZ	SAFETY INCENTIVE PRGM	-100.00
08/09/2024	JOE MEER	SAFETY INCENTIVE PRGM	-100.00
08/09/2024	JAMES MITCHELL	SAFETY INCENTIVE PRGM	-100.00
08/09/2024	SCOTT NOBEN	SAFETY INCENTIVE PRGM	-100.00
08/09/2024	JUAN OYOLA	SAFETY INCENTIVE PRGM	-100.00
08/09/2024	NICHOLAS PACO	SAFETY INCENTIVE PRGM	-100.00
08/09/2024	MICHAEL PADILLA	SAFETY INCENTIVE PRGM	-100.00
08/09/2024	RENEE PAYNE	SAFETY INCENTIVE PRGM	-100.00
08/09/2024	ANITA PETKE	SAFETY INCENTIVE PRGM	-100.00
08/09/2024	CHRISTOPHER RASMUSSEN	SAFETY INCENTIVE PRGM	-100.00
08/09/2024	JANUARY RODRIGUEZ	SAFETY INCENTIVE PRGM	-100.00
08/09/2024	ESMERALDA VILLA	SAFETY INCENTIVE PRGM	-100.00
08/09/2024	JAMES WATSON	SAFETY INCENTIVE PRGM	-100.00
08/09/2024	CITY OF TWENTYNINE PALMS	OUTSIDE SERVICES	-50.00
08/09/2024	COPPER MOUNTAIN BROADCASTING	MARKETING/PROMOTIONS	-460.00
08/09/2024	FORENSIC DRUG TESTING	TELEPHONE	-168.95
08/09/2024	GOLD MOUNTAIN CALIFORNIA NEW MEDIA INC.	MARKETING/PROMOTIONS	-744.75
08/09/2024	NAPA	PARTS, SHOPS SUPPLIES, FLUIDS	-666.95
08/09/2024	PALM SPRINGS MOTORS	PARTS	-314.41
08/09/2024	PARKHOUSE TIRES	TIRES	-945.49
08/09/2024	PRO SECURITY SYSTEMS	OUTSIDE SERVICES	-166.00
08/09/2024	PRUDENTIAL OVERALL SUPPLY	UNIFORMS & FACILITY SUPPLIES	-96.86
08/09/2024	RUTAN & TUCKER, LLP	PROFESSIONAL SERVICES	-533.40
08/09/2024	SONSRAY FLEET SERVICES	PARTS	-921.12
08/09/2024	ALLIANT INSURANCE SERVICES	INSURANCE	-40,509.19
08/09/2024	THOMAS HATHAWAY	EMPLOYEE EXPENSE	-14.67
08/09/2024	JUAN OYOLA	EMPLOYEE EXPENSE	-51.71
08/09/2024	SCOTT NOBEN	UNIFORM REIMBURSEMENT	-107.73
08/09/2024	KIMBERLY BERNARD	RETIREMENT LOAN OVRPYMNT	-402.52
08/09/2024	ADP	WAGES	-75,445.62
08/09/2024	ADP	WAGES	-14,808.25
08/09/2024	CALPERS 457 PROGRAM	SUPPL RETIREMENT	-4,747.51
08/09/2024	CALPERS HEALTH/RETIREMENT	RETIREMENT	-9,644.07
08/09/2024	CALPERS HEALTH/RETIREMENT	RETIREMENT	-5,237.14
08/09/2024	ADP	OUTSIDE SERVICES	-213.55
08/09/2024	PACIFIC WESTERN BANK	IN DISPUTE	-4,750.50
08/10/2024	BURRTEC	UTILITIES	-85.16
08/10/2024	BURRTEC	UTILITIES	-223.25
08/10/2024	NEC CLOUD COMMUNICATIONS AMERICA, INC.	TELEPHONE	-530.26
08/10/2024	BURRTEC	UTILITIES	-245.97

BASIN TRANSIT
WARRANT REGISTER
As of August 31, 2024

08/13/2024	ARCO	FUEL	-194.91
08/13/2024	AIS	PRINTING & REPRODUCTION	-78.25
08/13/2024	BROADLUX INC.	CNG MAINTENANCE	-662.00
08/13/2024	CARQUEST - YUCCA VALLEY	PARTS	-188.77
08/13/2024	CLEAN ENERGY	CNG MAINTENANCE	-3,000.00
08/13/2024	DESERT ARC	OUTSIDE SERVICES	-270.00
08/13/2024	FRONTIER COMMUNICATIONS	TELEPHONE	-287.30
08/13/2024	FRONTIER COMMUNICATIONS	TELEPHONE	-58.99
08/13/2024	PALM SPRINGS MOTORS	PARTS	-707.47
08/13/2024	PRUDENTIAL OVERALL SUPPLY	UNIFORMS & FACILITY SUPPLIES	-253.03
08/13/2024	SUNNY AND SONS	OUTSIDE SERVICES	-99.00
08/13/2024	THE GAS COMPANY	FUEL	-15,978.64
08/13/2024	VISUAL EDGE IT	CREDIT APPLIED	0.00
08/13/2024	VOYAGER	FUEL	-7,554.32
08/13/2024	HECTOR MANZANO	EMPLOYEE EXPENSE	-46.09
08/13/2024	SPECTRUM	TELEPHONE	-136.24
08/13/2024	PACIFIC WESTERN BANK	IN DISPUTE	-3,870.12
08/15/2024	TWENTYNINE PALMS WATER DISTRICT	UTILITIES	-51.54
08/15/2024	TWENTYNINE PALMS WATER DISTRICT	UTILITIES	-22.98
08/15/2024	HI DESERT WATER DISTRICT	UTILITIES	-188.93
08/15/2024	HI DESERT WATER DISTRICT	UTILITIES	-59.15
08/15/2024	CALPERS HEALTH/RETIREMENT	CERBT	-14,165.00
08/15/2024	CALPERS HEALTH/RETIREMENT	CEPPT	-10,034.00
08/15/2024	VISION SERVICE PLAN	VISION INSURANCE	-487.30
08/20/2024	JOSHUA BASIN WATER DISTRICT	UTILITIES	-242.90
08/20/2024	JOSHUA BASIN WATER DISTRICT	UTILITIES	-426.28
08/20/2024	ARCO	FUEL	-162.52
08/20/2024	JOSHUA TREE LANDSCAPE & GROUNDS MAINT	OUTSIDE SERVICES	-1,433.00
08/22/2024	ACE ALTERNATORS	PARTS	-288.19
08/22/2024	AIRWAVE COMMUNICATIONS	RADIO EXPENSE	-665.00
08/22/2024	BUSINESS RADIO LICENSING	RADIO EXPENSE	-115.00
08/22/2024	C&S ELECTRICAL	OUTSIDE SERVICES	-125.00
08/22/2024	CHARLES ABBOTT & ASSOCIATES INC.	PROFESSIONAL SERVICES	-2,280.00
08/22/2024	CLEAN ENERGY	CNG MAINTENANCE	-199.50
08/22/2024	FRONTIER COMMUNICATIONS	TELEPHONE	-73.32
08/22/2024	FRONTIER COMMUNICATIONS	TELEPHONE	-109.98
08/22/2024	PALM SPRINGS MOTORS	PARTS	-261.00
08/22/2024	PRUDENTIAL OVERALL SUPPLY	UNIFORMS & FACILITY SUPPLIES	-96.86
08/22/2024	QUILL CORPORATION	OFFICE SUPPLIES	-756.42
08/22/2024	RUSSELL AIR CONDITIONING INC.	OUTSIDE SERVICES	-6,500.00
08/22/2024	SAFELITE	OUTSIDE SERVICES	-1,578.32
08/22/2024	SCHROEDER PLUMBING	OUTSIDE SERVICES	-165.00
08/22/2024	VERIZON	TELEPHONE	-200.05
08/22/2024	YUCCA VALLEY TOWING INC	OUTSIDE SERVICES	-265.00
08/22/2024	DOUG HUNTER	UNIFORM REIMBURSEMENT	-30.44

BASIN TRANSIT
WARRANT REGISTER
As of August 31, 2024

08/22/2024	LYDIA KNUDSON	UNIFORM REIMBURSEMENT	-72.79
08/22/2024	MICHAL BROCK	TRAININGS/MEETINGS	-457.16
08/23/2024	ADP	WAGES	-78,880.33
08/23/2024	ADP	WAGES	-14,771.99
08/23/2024	AREG ABARYANTS	TREP MILEAGE REIMBURSEMENT	-120.00
08/23/2024	CALPERS 457 PROGRAM	SUPPL RETIREMENT	-5,113.18
08/23/2024	CALPERS HEALTH/RETIREMENT	RETIREMENT	-10,415.38
08/23/2024	CALPERS HEALTH/RETIREMENT	RETIREMENT	-5,244.45
08/23/2024	ADP	OUTSIDE SERVICES	-314.95
08/24/2024	SPECTRUM	TELEPHONE	-308.19
08/24/2024	TREP	TREP MILEAGE REIMBURSEMENT	-3,097.40
08/25/2024	THE GAS COMPANY	UTILITIES	-15.78
08/25/2024	JOSHUA TREE LANDSCAPE & GROUNDS MAINT	OUTSIDE SERVICES	-833.75
08/27/2024	ARCO	FUEL	-211.61
08/29/2024	CALPERS HEALTH/RETIREMENT	PROFESSIONAL SERVICES	-700.00
08/31/2024	[EMPLOYEE]	HRA REIMBURSEMENTS	-425.00
08/31/2024	[EMPLOYEE]	HRA REIMBURSEMENTS	-920.27
08/31/2024	[EMPLOYEE]	HRA REIMBURSEMENTS	-718.36
08/31/2024	[EMPLOYEE]	HRA REIMBURSEMENTS	-843.00
08/31/2024	[EMPLOYEE]	HRA REIMBURSEMENTS	-690.96
08/31/2024	[EMPLOYEE]	HRA REIMBURSEMENTS	-1,384.83
08/31/2024	[EMPLOYEE]	HRA REIMBURSEMENTS	-20.00
08/31/2024	[EMPLOYEE]	HRA REIMBURSEMENTS	-261.64
			<hr/>
			-447,126.02
			<hr/>
			-447,126.02
			<hr/>

BASIN TRANSIT
WARRANT REGISTER
 As of September 30, 2024

<u>Date</u>	<u>Name</u>	<u>Memo</u>	<u>Paid Amount</u>
09/01/2024	VISION SERVICE PLAN	VISION INSURANCE	487.30
09/02/2024	SPECTRUM	TELEPHONE	-161.24
09/02/2024	SPECTRUM	TELEPHONE	-136.24
09/03/2024	ARCO	FUEL	-106.81
09/03/2024	SENTINEL BENEFITS	OUTSIDE SERVICES	-25.00
09/04/2024	WEDNESDAY VEGAS	EMPLOYEE EXPENSE	-4,962.00
09/05/2024	SOUTHERN CALIFORNIA EDISON	UTILITIES	-15,276.99
09/05/2024	CALPERS HEALTH/RETIREMENT	HEALTH INSURANCE	-22,208.51
09/05/2024	ADP	OUTSIDE SERVICES	-591.40
09/06/2024	ADP	WAGES	-81,522.51
09/06/2024	ADP	WAGES	-15,410.01
09/06/2024	ADP	OUTSIDE SERVICES	-208.35
09/06/2024	CALPERS 457 PROGRAM	SUPPL RETIREMENT	-5,167.72
09/06/2024	CALPERS HEALTH/RETIREMENT	RETIREMENT	-10,470.68
09/06/2024	CALPERS HEALTH/RETIREMENT	RETIREMENT	-5,245.85
09/10/2024	ARCO	FUEL	-236.35
09/10/2024	BURRTEC	UTILITIES	-85.16
09/10/2024	BURRTEC	UTILITIES	-223.25
09/10/2024	BURRTEC	UTILITIES	-245.97
09/10/2024	NEC CLOUD COMMUNICATIONS AMERICA, INC.	TELEPHONE	-522.54
09/12/2024	ACE ALTERNATORS	PARTS	-205.54
09/12/2024	AVALON URGENT CARE	OUTSIDE SERVICES	-800.00
09/12/2024	BATTERY SYSTEMS	PARTS	-285.77
09/12/2024	BENEFIT COORDINATORS CORP	DENTAL INSURANCE	-1,438.70
09/12/2024	BROADLUX INC.	CNG MAINTENANCE	-662.00
09/12/2024	CLEAN ENERGY	CNG MAINTENANCE	-451.50
09/12/2024	COPPER MOUNTAIN BROADCASTING	MARKETING & PROMOTION	-440.00
09/12/2024	DIAMOND ENVIRONMENTAL SERVICES	UTILITIES	-122.87
09/12/2024	FORENSIC DRUG TESTING	EMPLOYEE EXPENSE	-528.85
09/12/2024	FRONTIER COMMUNICATIONS	TELEPHONE	0.00
09/12/2024	GEYSER EQUIPMENT LLC	PARTS	-412.03
09/12/2024	GOLD MOUNTAIN CALIFORNIA NEW MEDIA INC.	MARKETING & PROMOTION	-1,489.50
09/12/2024	KCDZ	MARKETING & PROMOTION	-920.00
09/12/2024	KK RENTS LLC	OUTSIDE SERVICES	-266.04
09/12/2024	MODEL 1 COMMERCIAL VEHICLES, INC.	PARTS	-288.38
09/12/2024	NAPA	PARTS	-767.16
09/12/2024	O'REILLY AUTO PARTS	PARTS	-100.09
09/12/2024	OLS SERVICE, INC.	OUTSIDE SERVICES	-1,639.95
09/12/2024	PALM SPRINGS MOTORS	PARTS	-919.23
09/12/2024	PARKHOUSE TIRES	TIRES	-3,052.62
09/12/2024	PRUDENTIAL OVERALL SUPPLY	UNIFORMS & SHOP SUPPLIES	-1,739.67
09/12/2024	QUILL CORPORATION	OFFICE SUPPLIES	-769.72

BASIN TRANSIT
WARRANT REGISTER
 As of September 30, 2024

09/12/2024	RUSSELL AIR CONDITIONING INC.	OUTSIDE SERVICES	-575.00
09/12/2024	RUTAN & TUCKER, LLP	PROFESSIONAL FEES	-315.20
09/12/2024	SAFETY-KLEEN	FLUIDS	-1,084.24
09/12/2024	THE GAS COMPANY	FUEL	-16,905.64
09/12/2024	VOYAGER	FUEL	-2,928.30
09/12/2024	KIMBERLY BERNARD	SUPPL RETIREMENT LOAD REFUND	-0.51
09/12/2024	NOEMI ADDERLEY	MILEAGE REIMBURSEMENT	-84.42
09/12/2024	ESMERALDA VILLA	EMPLOYEE EXPENSE	-10.00
09/12/2024	CHRISTINA GUTIERREZ	EMPLOYEE EXPENSE	-10.00
09/12/2024	NICHOLAS LUTRELL	EMPLOYEE EXPENSE	-10.00
09/12/2024	NICHOLAS LUTRELL	UNIFORM REIMBURSEMENT	-72.80
09/12/2024	NICHOLAS LUTRELL	EMPLOYEE EXPENSE	-75.00
09/12/2024	US BANK	CREDIT CARD PAYMENT	-3,251.93
09/12/2024	FRONTIER COMMUNICATIONS	TELEPHONE	-608.16
09/12/2024	FRONTIER COMMUNICATIONS	TELEPHONE	-287.30
09/15/2024	TWENTYNINE PALMS WATER DISTRICT	UTILITIES	-61.06
09/15/2024	TWENTYNINE PALMS WATER DISTRICT	UTILITIES	-22.98
09/15/2024	HI DESERT WATER DISTRICT	UTILITIES	-52.66
09/15/2024	HI DESERT WATER DISTRICT	UTILITIES	-188.93
09/15/2024	CALPERS HEALTH/RETIREMENT	CERBT	-14,165.00
09/15/2024	CALPERS HEALTH/RETIREMENT	CEPPT	-10,034.00
09/15/2024	VISION SERVICE PLAN	VISION INSURANCE	-451.94
09/17/2024	ARCO	FUEL	-182.15
09/19/2024	AIS	PRINTING & REPRODUCTION	-66.68
09/19/2024	CHARLES ABBOTT & ASSOCIATES INC.	PROFESSIONAL FEES	-5,405.00
09/19/2024	CITY OF TWENTYNINE PALMS	PROFESSIONAL FEES	-50.00
09/19/2024	DESERT ARC	OUTSIDE SERVICES	-270.00
09/19/2024	FRONTIER COMMUNICATIONS	TELEPHONE	-74.62
09/19/2024	FRONTIER COMMUNICATIONS	TELEPHONE	-73.32
09/19/2024	FRONTIER COMMUNICATIONS	TELEPHONE	-109.98
09/19/2024	MCCS	MARKETING & PROMOTION	-1,200.00
09/19/2024	NAPA	PARTS	-54.35
09/19/2024	PRO SECURITY SYSTEMS	OUTSIDE SERVICES	-156.00
09/19/2024	PRUDENTIAL OVERALL SUPPLY	UNIFORMS & SHOP SUPPLIES	-96.86
09/19/2024	QUILL CORPORATION	OFFICE SUPPLIES	-122.76
09/19/2024	SUNNY AND SONS	OUTSIDE SERVICES	-149.00
09/19/2024	TWENTYNINE PALMS WATER DISTRICT	UTILITIES	-30.00
09/19/2024	VERIZON	TELEPHONE	-200.05
09/19/2024	VISUAL EDGE IT	CREDIT APPLIED	0.00
09/19/2024	CHRISTINA GUTIERREZ	EMPLOYEE EXPENSE	-75.00
09/20/2024	JOSHUA BASIN WATER DISTRICT	UTILITIES	-1,304.43
09/20/2024	JOSHUA BASIN WATER DISTRICT	UTILITIES	-242.90
09/20/2024	[EMPLOYEE]	WAGES	-70.09

BASIN TRANSIT WARRANT REGISTER

As of September 30, 2024

09/20/2024	ADP	WAGES	-78,851.08
09/20/2024	ADP	WAGES	-14,760.51
09/20/2024	CALPERS HEALTH/RETIREMENT	RETIREMENT	-10,313.20
09/20/2024	CALPERS HEALTH/RETIREMENT	RETIREMENT	-5,158.84
09/20/2024	CALPERS 457 PROGRAM	SUPPL RETIREMENT	-5,152.28
09/20/2024	ADP	OUTSIDE SERVICES	-208.35
09/24/2024	ARCO	FUEL	-147.46
09/24/2024	SPECTRUM	TELEPHONE	-308.19
09/25/2024	THE GAS COMPANY	UTILITIES	-15.29
09/25/2024	JOSHUA TREE LANDSCAPE & GROUNDS MAINT	OUTSIDE SERVICES	-833.75
09/26/2024	ACE ALTERNATORS	PARTS	-288.19
09/26/2024	CARQUEST - YUCCA VALLEY	PARTS	-21.58
09/26/2024	CLEAN ENERGY	CNG MAINTENANCE	-3,000.00
09/26/2024	DEPARTMENT OF JUSTICE	EMPLOYEE EXPENSE	-96.00
09/26/2024	DIAMOND HILLS	PARTS	-156.85
09/26/2024	FRONTIER COMMUNICATIONS	TELEPHONE	-622.33
09/26/2024	GEYSER EQUIPMENT LLC	OUTSIDE SERVICES	-1,293.92
09/26/2024	GILLIG LLC	PARTS	-189.30
09/26/2024	JARRETT WALKER & ASSOCIATES	PROFESSIONAL FEES	-9,150.83
09/26/2024	NAPA	PARTS	-1,268.29
09/26/2024	PALM SPRINGS MOTORS	PARTS	-690.67
09/26/2024	PARKHOUSE TIRES	TIRES	-1,534.77
09/26/2024	PRUDENTIAL OVERALL SUPPLY	UNIFORMS & SHOP SUPPLIES	-257.62
09/26/2024	QUILL CORPORATION	OFFICE SUPPLIES	-107.74
09/26/2024	SAN BERNARDINO COUNTY FIRE PROTECTION	OUTSIDE SERVICES	-272.00
09/26/2024	SOUTHWEST NETWORKS	PROFESSIONAL FEES	-3,171.00
09/26/2024	THE TIRE HOUSE LLC	TIRES	-1,885.39
09/26/2024	YUCCA VALLEY TOWING INC	OUTSIDE SERVICES	-700.00
09/26/2024	CHRISTINA GUTIERREZ	UNIFORM REIMBURSEMENT	-85.85
09/27/2024	AREG ABARYANTS	TREP MILEAGE REIMBURSEMENT	-120.00
09/27/2024	TREP	TREP MILEAGE REIMBURSEMENTS	-3,480.40
09/30/2024	[EMPLOYEE]	HRA REIMBURSEMENT	-500.00
09/30/2024	[EMPLOYEE]	HRA REIMBURSEMENT	-457.27
09/30/2024	[EMPLOYEE]	HRA REIMBURSEMENT	-640.82
09/30/2024	[EMPLOYEE]	HRA REIMBURSEMENT	-1,799.96
09/30/2024	[EMPLOYEE]	HRA REIMBURSEMENT	-511.80
09/30/2024	[EMPLOYEE]	HRA REIMBURSEMENT	-55.00
09/30/2024	[EMPLOYEE]	HRA REIMBURSEMENT	-1,064.07
09/30/2024	[EMPLOYEE]	HRA REIMBURSEMENT	-296.67
09/30/2024	[EMPLOYEE]	HRA REIMBURSEMENT	-544.90
09/30/2024	BEN SASNETT	BOARD STIPEND	-100.00
			-390,859.33
			-390,859.33

BASIN TRANSIT

TO: Board of Directors
FROM: Cheri Holsclaw, General Manager
DATE: November 21, 2024

RE: Ridership Reports

Year-to-date, staff is still continuing to see an increase from the previous year with 3,436 (7%) more passengers in the first quarter. At over 47,000 passengers during the first quarter, we are on track to meet our FY25 Target of 154,0000.

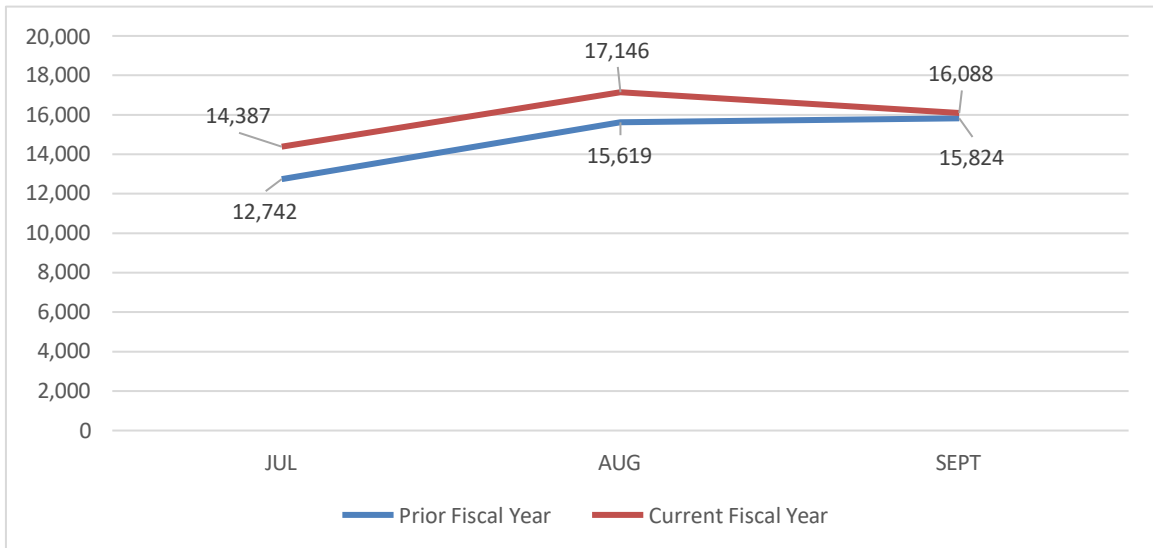

STAFF RECOMMENDATION: RECEIVE AND FILE

Performance Indicators & Data	Prior Year Total	Current Year Target	Current Year To Date	1st Qtr	2nd Qtr	3rd Qtr	4th Qtr	Year To Date Performance
Farebox Recovery Ratio	7.95%		8.10%	8.10%				Fails to Meet Target
Operating Costs Per Revenue Hour	\$138.19		\$142.73	\$142.73				Exceeds Target
Passenger Revenue Per Revenue Hour (a)	\$10.98		\$11.56	\$11.56				
Subsidy Per Revenue Hour	\$127.21		\$131.17	\$131.17				
Operating Cost Per Revenue Mile	\$7.00		\$7.07	\$7.07				Exceeds Target
Passenger Revenue Per Revenue Mile	\$0.56		\$0.57	\$0.57				
Subsidy Per Revenue Mile	\$6.45		\$6.50	\$6.50				
Operating Costs Per Passenger	\$23.93		\$23.99	\$23.99				Exceeds Target
Passenger Revenue Per Passenger (Avg Fare) (a)	\$1.90		\$1.94	\$1.94				
Subsidy Per Passenger	\$22.03		\$22.04	\$22.04				
Operating Cost Per Passenger Mile								
Passenger Revenue Per Passenger Mile (a)								
Subsidy Per Passenger Mile								
Passengers Per Revenue Hour	5.8		6.0	6.0				Fails to Meet Target
Passengers Per Revenue Mile	0.29		0.29	0.29				
Revenue Miles Between NTD Reportable Accidents (b)								
Percentage of Trips On Time	98.3%		98.1%	98.1%				
Passengers Served Between Complaints	5,477		15,874	15,874				
Complaints Per 100,000 Passengers	18.26		6.30	6.30				
Revenue Miles Between NTD System Failures (c)			53,822	53,822				
Total Miles Between Total NTD System Failures (c)			58,727	58,727				
Total Miles Between Major NTD System Failures (d)								
Passengers	186,234		47,621	47,621				Fails to Meet Target
Passenger Miles								
Revenue Hours	32,251		8,003	8,003				
Total Hours	35,302		8,795	8,795				
Revenue Miles	636,416		161,466	161,466				
Total Miles	694,193		176,180	176,180				
Operating Costs	\$4,456,627		\$1,142,244	\$1,142,244				
Passenger Revenue (a)	\$354,111		\$92,529	\$92,529				
Operating Subsidy	\$4,102,517		\$1,049,715	\$1,049,715				
NTD Reportable Accidents (b)	0		0	0				
Total Roadcalls (NTD System Failures) (c)	0		3	3				
Major Mechanical Failures (Roadcalls) (d)	0		0	0				
Complaints	34		3	3				
Trips On Time	15,278		3,785	3,785				
On-Time Performance Trips Sampled	15,544		3,860	3,860				

(a) Includes Auxiliary Revenues and other Local Support related to reduced fares. (b) Collision Accidents reportable per NTD Definition. (c) Total System Failures per NTD Definition. (d) Major System Failures per NTD Definition.

Total (All Day Types)

Service	Passengers		Passengers Per Revenue Hour		Farebox Recovery Ratio	
	Prior Year	Current Year	Prior Year	Current Year	Prior Year	Current Year
Route Subtotals						
1	6,893	7,739	8.4	9.7	21.74%	23.27%
12	466	337	2.8	2.3	14.28%	10.21%
15	92	147	1.8	2.1	4.02%	2.59%
1X	80	150	3.0	5.5	3.52%	8.39%
21	836	949	3.7	4.7	9.51%	2.63%
3A	1,366	1,525	5.8	6.8	7.04%	7.18%
3B	1,630	1,694	6.6	7.5	22.35%	7.40%
7A	1,556	1,691	6.5	7.8	12.81%	12.42%
7B	1,472	1,612	6.2	7.4	9.68%	9.01%
RR30	402	428	2.4	2.6	21.86%	19.71%
RR31	171	133	2.1	2.2	17.41%	16.72%
RR31/36		104		2.3		16.59%
RR34	279	266	2.3	2.3	19.03%	16.61%
RR36	50		1.4		12.17%	
RR50	326	371	1.8	2.2	16.06%	16.34%
Program Subtotals						
Commuter Service	558	484	2.6	2.2	11.67%	7.66%
Demand Response	1,228	1,302	2.1	2.4	18.25%	17.44%
Neighborhood Shuttles	13,833	15,360	6.8	8.0	16.09%	14.26%
System Total	15,619	17,146	5.5	6.4	16.09%	14.22%



FY 2025 -- Monthly Performance Statistics
Systemwide Summary
All Routes

Performance Statistics for August

<i>Level Item</i>	<i>Passengers</i>	<i>Revenue Hours</i>	<i>Operating Costs</i>	<i>Passenger Revenue</i>	<i>Passengers Per Rev. Hour</i>	<i>Operating Cost Per Passenger</i>	<i>Operating Cost Per Rev. Hour</i>	<i>Passenger Revenue Per Passenger</i>	<i>Passenger Revenue Per Rev. Hour</i>	<i>Farebox Recovery Ratio</i>
Reporting Route #:										
1	7,739	797.2	\$119,306	\$27,757	9.7	\$15.42	\$149.65	\$3.59	\$34.82	23.27%
1X	150	27.3	\$4,138	\$347	5.5	\$27.58	\$151.38	\$2.31	\$12.70	8.39%
3A	1,525	224.1	\$32,345	\$2,323	6.8	\$21.21	\$144.35	\$1.52	\$10.37	7.18%
3B	1,694	225.5	\$31,921	\$2,364	7.5	\$18.84	\$141.54	\$1.40	\$10.48	7.40%
7A	1,691	217.6	\$30,972	\$3,846	7.8	\$18.32	\$142.34	\$2.27	\$17.67	12.42%
7B	1,612	218.9	\$31,640	\$2,851	7.4	\$19.63	\$144.56	\$1.77	\$13.03	9.01%
12	337	149.7	\$26,224	\$2,678	2.3	\$77.82	\$175.24	\$7.95	\$17.90	10.21%
15	147	71.8	\$13,191	\$342	2.1	\$89.73	\$183.71	\$2.33	\$4.77	2.59%
21	949	202.1	\$32,510	\$855	4.7	\$34.26	\$160.83	\$0.90	\$4.23	2.63%
RR30	428	164.6	\$22,201	\$4,375	2.6	\$51.87	\$134.92	\$10.22	\$26.59	19.71%
RR31	133	59.6	\$8,134	\$1,360	2.2	\$61.15	\$136.47	\$10.22	\$22.81	16.72%
RR31/36	104	45.3	\$6,409	\$1,063	2.3	\$61.62	\$141.63	\$10.22	\$23.49	16.59%
RR34	266	115.0	\$16,370	\$2,719	2.3	\$61.54	\$142.39	\$10.22	\$23.65	16.61%
RR50	371	169.9	\$23,216	\$3,792	2.2	\$62.58	\$136.62	\$10.22	\$22.32	16.34%
Program:										
Commuter Service	484	221.5	\$39,415	\$3,021	2.2	\$81.44	\$177.99	\$6.24	\$13.64	7.66%
Demand Response	1,302	554.3	\$76,328	\$13,309	2.4	\$58.62	\$137.70	\$10.22	\$24.01	17.44%
Neighborhood Shuttles	15,360	1,912.8	\$282,833	\$40,342	8.0	\$18.41	\$147.87	\$2.63	\$21.09	14.26%
Mode:										
Bus (Motorbus)	15,360	1,912.8	\$282,833	\$40,342	8.0	\$18.41	\$147.87	\$2.63	\$21.09	14.26%
Commuter Bus	484	221.5	\$39,415	\$3,021	2.2	\$81.44	\$177.99	\$6.24	\$13.64	7.66%
Demand Response	1,302	554.3	\$76,328	\$13,309	2.4	\$58.62	\$137.70	\$10.22	\$24.01	17.44%
System Total:	17,146	2,688.5	\$398,576	\$56,672	6.4	\$23.25	\$148.25	\$3.31	\$21.08	14.22%



Monthly Ridership Report
September, FY 2025

Total (All Day Types)

Service	Passengers		Passengers Per Revenue Hour		Farebox Recovery Ratio	
	Prior Year	Current Year	Prior Year	Current Year	Prior Year	Current Year
Route Subtotals						
1	7,504	7,627	9.9	10.0	7.69%	13.35%
12	429	333	2.9	2.3	13.11%	12.86%
15	176	111	2.6	1.6	7.31%	4.05%
1X	72	224	2.7	6.5	0.96%	5.80%
21	790	834	4.1	4.6	2.70%	1.03%
3A	1,271	1,448	5.9	6.5	1.75%	4.06%
3B	1,555	1,621	7.3	7.1	4.21%	4.00%
7A	1,358	1,358	6.2	6.4	3.25%	5.86%
7B	1,458	1,387	6.6	6.5	2.40%	4.47%
RR30	374	344	2.6	2.3	2.93%	1.23%
RR31	151	94	2.0	2.2	2.17%	1.14%
RR31/36		100		2.4		1.21%
RR34	297	250	2.8	2.1	2.90%	1.02%
RR36	45		1.2		1.58%	
RR50	344	357	2.1	2.4	2.35%	1.23%
Program Subtotals						
Commuter Service	605	444	2.8	2.1	11.24%	9.97%
Demand Response	1,211	1,145	2.3	2.3	2.55%	1.17%
Neighborhood Shuttles	14,008	14,499	7.6	7.8	4.86%	7.89%
System Total	15,824	16,088	6.1	6.3	5.08%	6.87%



FY 2025 -- Monthly Performance Statistics
Systemwide Summary
All Routes

Performance Statistics for September

<i>Level Item</i>	<i>Passengers</i>	<i>Revenue Hours</i>	<i>Operating Costs</i>	<i>Passenger Revenue</i>	<i>Passengers Per Rev. Hour</i>	<i>Operating Cost Per Passenger</i>	<i>Operating Cost Per Rev. Hour</i>	<i>Passenger Revenue Per Passenger</i>	<i>Passenger Revenue Per Rev. Hour</i>	<i>Farebox Recovery Ratio</i>
Reporting Route #:										
1	7,627	761.0	\$111,584	\$14,896	10.0	\$14.63	\$146.64	\$1.95	\$19.58	13.35%
1X	224	34.5	\$5,075	\$294	6.5	\$22.66	\$147.18	\$1.31	\$8.53	5.80%
3A	1,448	222.6	\$31,231	\$1,266	6.5	\$21.57	\$140.29	\$0.87	\$5.69	4.06%
3B	1,621	228.8	\$31,945	\$1,278	7.1	\$19.71	\$139.61	\$0.79	\$5.59	4.00%
7A	1,358	212.5	\$29,090	\$1,704	6.4	\$21.42	\$136.88	\$1.25	\$8.02	5.86%
7B	1,387	212.4	\$29,281	\$1,309	6.5	\$21.11	\$137.89	\$0.94	\$6.16	4.47%
12	333	144.4	\$24,097	\$3,098	2.3	\$72.36	\$166.84	\$9.30	\$21.45	12.86%
15	111	67.9	\$11,742	\$475	1.6	\$105.78	\$173.01	\$4.28	\$7.00	4.05%
21	834	181.6	\$28,313	\$292	4.6	\$33.95	\$155.91	\$0.35	\$1.61	1.03%
RR30	344	147.6	\$19,220	\$236	2.3	\$55.87	\$130.20	\$0.69	\$1.60	1.23%
RR31	94	43.8	\$5,671	\$64	2.2	\$60.33	\$129.53	\$0.69	\$1.47	1.14%
RR31/36	100	41.9	\$5,671	\$69	2.4	\$56.71	\$135.39	\$0.69	\$1.64	1.21%
RR34	250	117.5	\$16,862	\$171	2.1	\$67.45	\$143.51	\$0.69	\$1.46	1.02%
RR50	357	152.0	\$19,972	\$245	2.4	\$55.94	\$131.44	\$0.69	\$1.61	1.23%
Program:										
Commuter Service	444	212.3	\$35,839	\$3,573	2.1	\$80.72	\$168.81	\$8.05	\$16.83	9.97%
Demand Response	1,145	502.7	\$67,396	\$785	2.3	\$58.86	\$134.06	\$0.69	\$1.56	1.17%
Neighborhood Shuttles	14,499	1,853.3	\$266,520	\$21,039	7.8	\$18.38	\$143.81	\$1.45	\$11.35	7.89%
Mode:										
Bus (Motorbus)	14,499	1,853.3	\$266,520	\$21,039	7.8	\$18.38	\$143.81	\$1.45	\$11.35	7.89%
Commuter Bus	444	212.3	\$35,839	\$3,573	2.1	\$80.72	\$168.81	\$8.05	\$16.83	9.97%
Demand Response	1,145	502.7	\$67,396	\$785	2.3	\$58.86	\$134.06	\$0.69	\$1.56	1.17%
System Total:	16,088	2,568.4	\$369,755	\$25,397	6.3	\$22.98	\$143.97	\$1.58	\$9.89	6.87%

BASIN TRANSIT

TO: Board of Directors
FROM: Cheri Holsclaw, General Manager
DATE: November 21, 2024

RE: Financial Report

At the conclusion of September, Basin Transit expenses were \$117,846 (9%) below budget.

Passenger Fares were \$19,791 (27%) higher than anticipated.

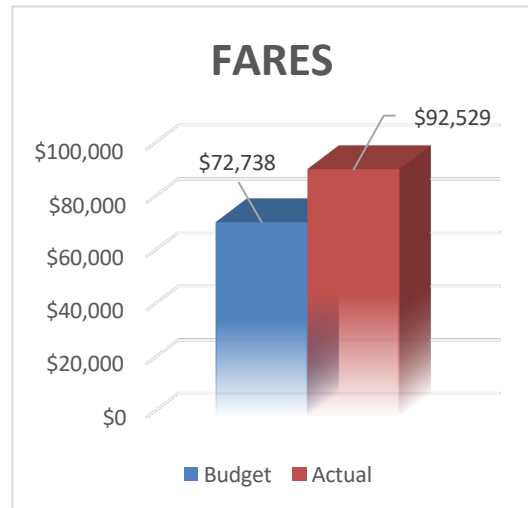
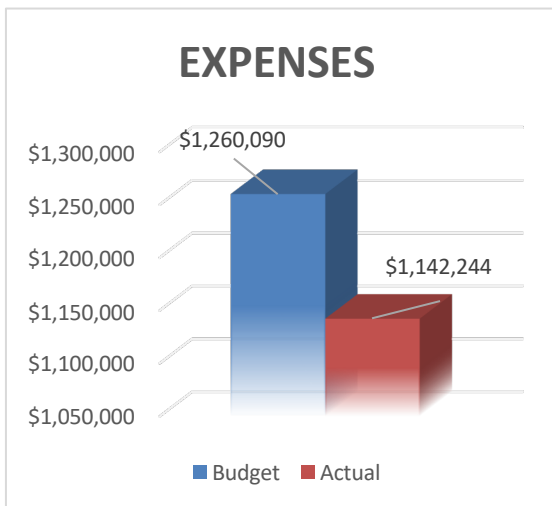

STAFF RECOMMENDATION: RECEIVE AND FILE

BASIN TRANSIT
Statement of Expenditures - Cash Basis
During Fiscal Year ending 06/30/2025
For Period Ending 8/31/2024

Line	Administrative Exp.	FY 24/25 Budget	AUGUST		Year to Date		Year to Date Variance	%
			Budget	Actual	Budget	Actual		
1	Mgmt. Salaries	\$ 148,086.00	\$ 11,391.23	\$ 11,358.41	\$ 22,782.46	\$ 22,636.47	\$ 145.99	1%
2	Office Salaries	\$ 177,168.00	\$ 13,628.31	\$ 11,603.01	\$ 27,256.62	\$ 25,474.33	\$ 1,782.29	7%
3	Board Members	\$ 4,200.00	\$ -	\$ -	\$ 700.00	\$ 700.00	\$ -	0%
4	Payroll Taxes	\$ 11,880.00	\$ 913.85	\$ 551.77	\$ 1,827.69	\$ 1,136.59	\$ 691.10	38%
5	Health & Welfare	\$ 76,833.00	\$ 6,402.75	\$ 7,334.89	\$ 12,805.50	\$ 18,936.48	\$ (6,130.98)	-48%
6	Retirement:PERS	\$ 52,666.00	\$ 4,051.23	\$ 4,425.60	\$ 8,102.46	\$ 8,833.60	\$ (731.14)	-9%
7	Mileage	\$ 5,000.00	\$ 416.67	\$ 256.63	\$ 833.33	\$ 383.26	\$ 450.07	54%
8	Outside Services	\$ 31,228.00	\$ 2,602.33	\$ 20,901.52	\$ 5,204.67	\$ 20,746.75	\$ (15,542.08)	-299%
9	Prof. Fees	\$ 78,507.00	\$ 6,542.25	\$ 3,563.40	\$ 13,084.50	\$ 8,092.40	\$ 4,992.10	38%
10	Utilities	\$ 178,760.00	\$ 14,896.67	\$ 18,423.55	\$ 29,793.33	\$ 31,754.39	\$ (1,961.06)	-7%
11	Marketing/Promotions	\$ 50,493.00	\$ 4,207.75	\$ 1,204.75	\$ 8,415.50	\$ 3,619.14	\$ 4,796.36	57%
12	Office Supplies	\$ 16,882.00	\$ 1,406.83	\$ 1,234.79	\$ 2,813.67	\$ 2,557.39	\$ 256.28	9%
13	Postage	\$ 2,503.00	\$ 208.58	\$ 93.79	\$ 417.17	\$ 223.35	\$ 193.82	46%
14	Printing/Reproduction	\$ 14,425.00	\$ 1,202.08	\$ 78.25	\$ 2,404.17	\$ 221.50	\$ 2,182.67	91%
15	Training/Meetings	\$ 14,831.00	\$ 1,235.92	\$ 1,113.93	\$ 2,471.83	\$ 2,173.46	\$ 298.37	12%
16	Total Administrative	\$ 863,463.00	\$ 69,106.45	\$ 82,144.29	\$ 138,912.90	\$ 147,489.11	\$ (8,576.21)	-6%
Maintenance Expense								
17	Mechanic Salaries	\$ 204,629.00	\$ 15,740.69	\$ 15,170.72	\$ 31,481.38	\$ 30,651.04	\$ 830.34	3%
18	Utility Workers & Maint Admin Salaries	\$ 135,094.00	\$ 10,391.85	\$ 9,925.97	\$ 20,783.69	\$ 19,492.53	\$ 1,291.16	6%
19	Payroll Taxes	\$ 8,037.00	\$ 618.23	\$ 369.63	\$ 1,236.46	\$ 732.62	\$ 503.84	41%
20	Health & Welfare	\$ 29,237.00	\$ 2,436.42	\$ 1,603.06	\$ 4,872.83	\$ 3,453.13	\$ 1,419.70	29%
21	Retirement:PERS	\$ 24,452.00	\$ 1,880.92	\$ 918.52	\$ 3,761.85	\$ 1,923.84	\$ 1,838.01	49%
22	Uniforms	\$ 4,418.00	\$ 368.17	\$ 299.68	\$ 736.33	\$ 674.28	\$ 62.05	8%
23	Outside Services	\$ 52,622.00	\$ 4,385.17	\$ 6,678.49	\$ 8,770.33	\$ 9,935.74	\$ (1,165.41)	-13%
24	Parts	\$ 72,294.00	\$ 6,024.50	\$ 3,927.70	\$ 12,049.00	\$ 11,058.52	\$ 990.48	8%
25	Fluids	\$ 18,071.00	\$ 1,505.92	\$ 282.27	\$ 3,011.83	\$ 3,997.09	\$ (985.26)	-33%
26	Tires	\$ 63,251.00	\$ 5,270.92	\$ 945.49	\$ 10,541.83	\$ 4,971.86	\$ 5,569.97	53%
27	Accident Repair	\$ 26,369.00	\$ 2,197.42	\$ -	\$ 4,394.83	\$ -	\$ 4,394.83	100%
28	Tools	\$ 750.00	\$ 62.50	\$ -	\$ 125.00	\$ 250.00	\$ (125.00)	-100%
29	Consulting	\$ 1,000.00	\$ 83.33	\$ -	\$ 166.67	\$ -	\$ 166.67	100%
30	Shop Supplies	\$ 1,000.00	\$ 83.33	\$ 315.51	\$ 166.67	\$ 349.22	\$ (182.55)	-110%
31	Facility Supplies	\$ 6,022.00	\$ 501.83	\$ 505.84	\$ 1,003.67	\$ 1,040.06	\$ (36.39)	-4%
32	Training/Meetings	\$ 6,174.00	\$ 514.50	\$ -	\$ 1,029.00	\$ -	\$ 1,029.00	100%
33	Shelter Maintenance	\$ 2,784.00	\$ 232.00	\$ -	\$ 464.00	\$ -	\$ 464.00	100%
34	CNG Stations Maint.	\$ 115,874.00	\$ 9,656.17	\$ 9,200.33	\$ 19,312.33	\$ 9,862.33	\$ 9,450.00	49%
35	Total Maintenance	\$ 772,079.00	\$ 61,953.86	\$ 50,143.21	\$ 123,907.72	\$ 98,392.26	\$ 25,515.46	21%
Operations Expense								
36	Mgmt/Supv Salaries	\$ 195,524.00	\$ 15,040.31	\$ 14,424.24	\$ 30,080.62	\$ 28,898.80	\$ 1,181.82	4%
37	Operator Wages	\$ 1,437,485.00	\$ 110,575.77	\$ 106,672.12	\$ 221,151.54	\$ 215,808.11	\$ 5,343.43	2%
38	Dispatch Wages	\$ 269,928.00	\$ 20,763.69	\$ 19,218.11	\$ 41,527.38	\$ 41,116.95	\$ 410.43	1%
39	Payroll Taxes	\$ 45,670.00	\$ 3,513.08	\$ 2,309.63	\$ 7,026.15	\$ 4,371.82	\$ 2,654.33	38%
40	Health & Welfare	\$ 280,831.00	\$ 23,402.58	\$ 24,932.33	\$ 46,805.17	\$ 49,780.69	\$ (2,975.52)	-6%
41	Retirement:PERS	\$ 262,886.00	\$ 20,222.00	\$ 20,753.62	\$ 40,444.00	\$ 41,580.69	\$ (1,136.69)	-3%
42	Safety Incentive Program	\$ 12,900.00	\$ 1,075.00	\$ 4,100.00	\$ 2,150.00	\$ 4,100.00	\$ (1,950.00)	-91%
43	Workers'Comp	\$ 217,350.00	\$ 18,112.50	\$ 15,518.67	\$ 36,225.00	\$ 31,037.34	\$ 5,187.66	14%
44	Other Employee Exp.	\$ 36,409.00	\$ 3,034.08	\$ 1,159.11	\$ 6,068.17	\$ 3,051.54	\$ 3,016.63	50%
45	Mileage	\$ 1,850.00	\$ 154.17	\$ -	\$ 308.33	\$ -	\$ 308.33	100%
46	Uniforms	\$ 8,076.00	\$ 673.00	\$ 210.96	\$ 1,346.00	\$ 432.59	\$ 913.41	68%
47	Outside Services	\$ 16,635.00	\$ 1,386.25	\$ 166.00	\$ 2,772.50	\$ 166.00	\$ 2,606.50	94%
48	Tel/Cell/Internet/Fax	\$ 53,638.00	\$ 4,469.83	\$ 3,853.55	\$ 8,939.67	\$ 6,898.84	\$ 2,040.83	23%
49	Radio Expense	\$ 5,935.00	\$ 494.58	\$ 780.00	\$ 989.17	\$ 780.00	\$ 209.17	21%
50	Fuel	\$ 336,885.00	\$ 28,073.75	\$ 24,378.68	\$ 56,147.50	\$ 40,901.72	\$ 15,245.78	27%
51	Trainings/Meetings	\$ 4,400.00	\$ 366.67	\$ 435.05	\$ 733.33	\$ 1,038.51	\$ (305.18)	-42%
52	Insurance	\$ 398,598.00	\$ 33,216.50	\$ 23,277.12	\$ 66,433.00	\$ 48,568.24	\$ 17,864.76	27%
53	Deferred Comp Match	\$ 51,080.00	\$ 3,929.23	\$ 4,099.24	\$ 7,858.46	\$ 8,198.48	\$ (340.02)	-4%
54	Total Operations	\$ 3,636,081.00	\$ 288,502.99	\$ 266,288.43	\$ 577,005.99	\$ 526,730.32	\$ 50,275.67	9%
55	Grand Total of Op Exp	\$ 5,271,622.00	\$ 419,563.30	\$ 398,575.93	\$ 839,826.60	\$ 772,611.69	\$ 67,214.91	8%

BASIN TRANSIT
Statement of Income
For Period Ending 8/31/2024

Other Revenue		AUGUST			YTD Bdgt	YTD Actual		
1	Interest	\$ 39,476.00	\$ 3,289.67	\$ 110.06	\$ 6,579.33	\$ 38,701.41	\$ 32,122.08	488%
2	Other Revenue	\$ 24,195.00	\$ 2,016.25	\$ 200.00	\$ 4,032.50	\$ 431.74	\$ (3,600.76)	-89%
3	CNG Fuel	\$ 106,837.00	\$ 8,903.08	\$ -	\$ 17,806.17	\$ 8,982.76	\$ (8,823.41)	-50%
4	Renewable Gas Credits	\$ 60,093.00	\$ 5,007.75	\$ 6,254.80	\$ 10,015.50	\$ 12,549.55	\$ 2,534.05	25%
5	Insurance	\$ -	\$ -	\$ -	\$ -	\$ -	\$ -	100%
6	Gain on Sale of Assets	\$ -	\$ -	\$ -	\$ -	\$ -	\$ -	100%
7	Total Other Revenue	\$ 230,601.00	\$ 19,216.75	\$ 6,564.86	\$ 38,433.50	\$ 60,665.46	\$ 22,231.96	58%

Passenger Fares		AUGUST			YTD Bdgt	YTD Actual		
8	Fixed Route	\$ 179,543.00	\$ 14,961.92	\$ 32,863.11	\$ 29,923.83	\$ 38,690.72	\$ 8,766.89	29%
9	Ready Ride	\$ 19,676.00	\$ 1,639.67	\$ 13,309.47	\$ 3,279.33	\$ 14,977.17	\$ 11,697.84	357%
9	Palm Spr./Palm Des.	\$ 46,731.00	\$ 3,894.25	\$ 3,020.72	\$ 7,788.50	\$ 5,985.81	\$ (1,802.69)	-23%
10	LCTOP FY24/25 K-12 and 35 Days Free Fare Promotion	\$ 45,000.00	\$ 3,750.00	\$ 7,478.50	\$ 7,500.00	\$ 7,478.50	\$ (21.50)	0%
11	Total Fare Revenue	\$ 290,950.00	\$ 24,245.83	\$ 56,671.80	\$ 48,491.67	\$ 67,132.20	\$ 18,640.53	38%

Current Support Funding - Operations		Grant Amt	Received	Received in Previous FY(s)	Received Current FY	Balance Due
12	Local Transit Funds	\$ 4,001,456.00	\$ -	\$ 1,000,364.00	\$ 1,000,364.00	\$ 3,001,092.00
13	Section 5311 Operating Asst	\$ 555,516.00	\$ -	\$ -	\$ -	\$ 555,516.00
14	Measure I	\$ 153,100.00	\$ -	\$ 13,803.49	\$ 29,188.04	\$ 123,911.96
16	AB 2766	\$ 40,000.00	\$ -	\$ -	\$ -	\$ 40,000.00
17	Total Sup. Fund.Ops	\$4,750,072.00	\$ -	\$ 1,014,167.49	\$ 1,029,552.04	\$ 3,720,519.96

18	Total Operating Revenues	\$ 5,271,622.00	\$ -	\$ 1,077,404.15	\$ 1,157,349.70	\$ 3,761,392.45
----	---------------------------------	------------------------	-------------	------------------------	------------------------	------------------------

Prior Year Support Funding - Operations		Grant Amt	Received	Received in Previous FY(s)	Received Current FY	Balance Due
19	Section 5311 Operating Asst FY23	\$ 579,901.00	\$ -	\$ -	\$ -	\$ 579,901.00
20	Total Prior Year Operating Revenues	\$ 579,901.00	\$ -	\$ -	\$ -	\$ 579,901.00

Current Year Capital Funding - Capital		Grant Amt	Received	Received in Previous FY(s)	Received Current FY	Balance Due
21	Operations Support Equip STA FY25	\$ 50,000.00				\$ 50,000.00
22	CERBT / CEPPT Trust LTF FY25	\$ 290,388.00			\$ -	\$ 290,388.00
23	Engine Overhauls STA FY25	\$ 50,000.00				\$ 50,000.00
24	Vehicle Replacements STA/LTF/CMAQ FY25	\$ 1,164,329.00				\$ 1,164,329.00
25	Intelligent Transit System (ITS) STA/LTF/SGR FY25	\$ 900,000.00				\$ 900,000.00
26	Short Range Transit Plan (SRTP) STA FY25	\$ 100,000.00				\$ 100,000.00
27	Zero Emission RFP ZETCP FY25	\$ 246,734.00				\$ 246,734.00
28	Facilities LTF FY25	\$ 84,081.00				\$ 84,081.00
29	Bus Stop Improvements/PV Stops STA/LTF/LCTOP FY25	\$ 219,440.00				\$ 219,440.00
30	Total Current Capital Funding	\$ 3,104,972.00	\$ -	\$ -	\$ -	\$ 3,104,972.00

Previous Year(s) Capital Funding - Capital		Grant Amt	Received	Received in Previous FY(s)	Received Current FY	Balance Due
31	29Palms CNG Station LTF FY18	\$ 130,000.00				\$ 130,000.00
32	AVL/GPS Equipment STA FY17	\$ 6,000.00				\$ 6,000.00
33	AVL/GPS Equipment STA FY19	\$ 85,000.00				\$ 85,000.00
35	Bus Stop Improvements STA FY19	\$ 70,000.00		\$ 16,473.85		\$ 53,526.15
34	Bus Stop Improvements STA FY22	\$ 17,403.00				\$ 17,403.00
36	Bus Stop Improvements STA/SGR/LTF/LCTOP FY23	\$ 357,252.00		\$ 313,182.65	\$ 20,033.75	\$ 24,035.60
36	Bus Stop Improvements STA/LCTOP FY24	\$ 178,508.00		\$ 137,616.00		\$ 40,892.00
37	Bus Wash System STA FY20	\$ 67,950.00		\$ 4,310.00		\$ 63,640.00
38	Bus Wash System STA FY21	\$ 7,500.00				\$ 7,500.00
39	CERBT / CEPPT Trust LTF FY24	\$ 290,388.00		\$ 145,194.00	\$ 72,597.00	\$ 72,597.00
40	CNG Compressor LTF FY23	\$ 650,000.00				\$ 650,000.00
41	Cost Allocation Study STA FY19	\$ 20,000.00		\$ 17,481.00		\$ 2,519.00
42	Engine Overhauls STA/LTF FY23	\$ 75,000.00		\$ 51,470.23		\$ 23,529.77
43	Facilities STA/LTF FY23	\$ 150,000.00		\$ 103,013.79	\$ 6,212.53	\$ 40,773.68
44	Facilities LTF FY24	\$ 1,012,587.00			\$ 3,187.47	\$ 1,009,399.53
45	Fare Media Structure STA FY21	\$ 50,000.00				\$ 50,000.00
46	Intelligent Transit System (ITS) SGR/LTF FY24	\$ 439,000.00		\$ 97,903.98		\$ 341,096.02
47	Operations Support Equip STA FY24	\$ 50,000.00		\$ 25,160.69	\$ 4,647.70	\$ 20,191.61
48	REI Equipment LTF FY15 Realloc.	\$ 760.00				\$ 760.00
49	Short Range Transit Plan STA FY19	\$ 107,000.00		\$ 87,770.10		\$ 19,229.90
50	Staff Vehicles Replacemen STA FY20	\$ 50,000.00		\$ 49,812.68		\$ 187.32
51	Vehicles Replacements: 1 Class E STA FY19	\$ 68,368.00		\$ 2,385.95		\$ 65,982.05
52	Vehicle Replacements STA FY22 / CMAQ	\$ 287,076.00				\$ 287,076.00
53	Vehicle Replacements LTF FY23	\$ 1,079,970.00			\$ 198,972.45	\$ 880,997.55
54	Vehicle Replacements STA/CMAQ FY24	\$ 823,183.00				\$ 823,183.00
55	Zero Emission Projects LTF/LCTOP FY23	\$ 369,937.22		\$ 24,060.00		\$ 345,877.22
56	Total Prior Capital Funding	\$6,442,882.22	\$0.00	\$1,051,774.92	\$305,650.90	\$5,061,396.40

FY 24/25 Procurement Budget			Sent	Received	Sent	Received	Balance Due
57	Procurement Bid Income	\$ 320,000.00		\$ 22,672.85		\$ 51,494.22	\$ 268,505.78
58	Procurement Bid Expenses	\$ (193,601.00)	\$ 10,107.20		\$ 37,023.40		\$ (156,577.60)
59	TAG Program	\$ (80,000.00)					\$ (80,000.00)
60	Total Procurement Budget	\$ 46,399.00	\$ 10,107.20	\$ 22,672.85	\$ 37,023.40	\$ 51,494.22	\$ 14,470.82

FY 24/25 TREP Budget		Grant Amt	Sent	Received	Sent	Received	Balance Due
61	5310 TREP Revenue	<i>Previous Grant Balance</i>	\$ 217.07			\$ 217.07	\$ -
62	5310 TREP Revenue	<i>FY25 Award Allocation</i>	\$ 114,526.00				\$ 114,526.00
63	Program Administrator		\$ (2,298.00)	\$ 127.67	\$ 255.34		\$ (2,042.66)
64	Client Relations Clerk		\$ (53,325.00)	\$ 4,512.48	\$ 7,999.39		\$ (45,325.61)
65	TREP Program Expenses		\$ (1,000.00)				\$ (785.00)
66	Mileage Reimbursements		\$ (57,903.00)	\$ 3,217.40	\$ 6,606.16		\$ (51,296.84)
67	Total TREP Funding	\$ 217.07	\$ 7,857.55	\$ -	\$ 14,860.89	\$ 217.07	\$ (14,643.82)

BASIN TRANSIT
Statement of Expenditures - Cash Basis
During Fiscal Year ending 06/30/2025
For Period Ending 9/30/2024

Line	Administrative Exp.	FY 24/25 Budget	SEPTEMBER		Year to Date		Year to Date Variance	%
			Budget	Actual	Budget	Actual		
1	Mgmt. Salaries	\$ 148,086.00	\$ 11,391.23	\$ 11,358.42	\$ 34,173.69	\$ 33,994.89	\$ 178.80	1%
2	Office Salaries	\$ 177,168.00	\$ 13,628.31	\$ 12,823.26	\$ 40,884.92	\$ 38,174.81	\$ 2,710.11	7%
3	Board Members	\$ 4,200.00	\$ 700.00	\$ 100.00	\$ 1,400.00	\$ 800.00	\$ 600.00	43%
4	Payroll Taxes	\$ 11,880.00	\$ 913.85	\$ 553.88	\$ 2,741.54	\$ 1,690.47	\$ 1,051.07	38%
5	Health & Welfare	\$ 76,833.00	\$ 6,402.75	\$ 6,558.32	\$ 19,208.25	\$ 25,494.80	\$ (6,286.55)	-33%
6	Retirement:PERS	\$ 52,666.00	\$ 4,051.23	\$ 4,400.52	\$ 12,153.69	\$ 13,234.12	\$ (1,080.43)	-9%
7	Mileage	\$ 5,000.00	\$ 416.67	\$ 84.42	\$ 1,250.00	\$ 467.68	\$ 782.32	63%
8	Outside Services	\$ 31,228.00	\$ 2,602.33	\$ (17,099.03)	\$ 7,807.00	\$ 3,647.72	\$ 4,159.28	53%
9	Prof. Fees	\$ 78,507.00	\$ 6,542.25	\$ 8,941.20	\$ 19,626.75	\$ 17,033.60	\$ 2,593.15	13%
10	Utilities	\$ 178,760.00	\$ 14,896.67	\$ 17,872.49	\$ 44,690.00	\$ 49,626.88	\$ (4,936.88)	-11%
11	Marketing/Promotions	\$ 50,493.00	\$ 4,207.75	\$ 4,049.50	\$ 12,623.25	\$ 7,668.64	\$ 4,954.61	39%
12	Office Supplies	\$ 16,882.00	\$ 1,406.83	\$ 1,209.41	\$ 4,220.50	\$ 3,766.80	\$ 453.70	11%
13	Postage	\$ 2,503.00	\$ 208.58	\$ 155.94	\$ 625.75	\$ 379.29	\$ 246.46	39%
14	Printing/Reproduction	\$ 14,425.00	\$ 1,202.08	\$ 76.84	\$ 3,606.25	\$ 298.34	\$ 3,307.91	92%
15	Training/Meetings	\$ 14,831.00	\$ 1,235.92	\$ 1,634.05	\$ 3,707.75	\$ 3,807.51	\$ (99.76)	-3%
16	Total Administrative	\$ 863,463.00	\$ 69,806.45	\$ 52,719.22	\$ 208,719.35	\$ 200,085.55	\$ 8,633.80	4%
Maintenance Expense								
17	Mechanic Salaries	\$ 204,629.00	\$ 15,740.69	\$ 16,055.61	\$ 47,222.08	\$ 46,706.65	\$ 515.43	1%
18	Utility Workers & Maint Admin Salaries	\$ 135,094.00	\$ 10,391.85	\$ 9,755.29	\$ 31,175.54	\$ 29,247.82	\$ 1,927.72	6%
19	Payroll Taxes	\$ 8,037.00	\$ 618.23	\$ 374.10	\$ 1,854.69	\$ 1,106.72	\$ 747.97	40%
20	Health & Welfare	\$ 29,237.00	\$ 2,436.42	\$ 1,580.30	\$ 7,309.25	\$ 5,033.43	\$ 2,275.82	31%
21	Retirement:PERS	\$ 24,452.00	\$ 1,880.92	\$ 959.88	\$ 5,642.77	\$ 2,883.72	\$ 2,759.05	49%
22	Uniforms	\$ 4,418.00	\$ 368.17	\$ 385.49	\$ 1,104.50	\$ 1,059.77	\$ 44.73	4%
23	Outside Services	\$ 52,622.00	\$ 4,385.17	\$ 5,868.85	\$ 13,155.50	\$ 15,804.59	\$ (2,649.09)	-20%
24	Parts	\$ 72,294.00	\$ 6,024.50	\$ 4,939.72	\$ 18,073.50	\$ 15,998.24	\$ 2,075.26	11%
25	Fluids	\$ 18,071.00	\$ 1,505.92	\$ 1,503.76	\$ 4,517.75	\$ 5,500.85	\$ (983.10)	-22%
26	Tires	\$ 63,251.00	\$ 5,270.92	\$ 6,597.13	\$ 15,812.75	\$ 11,568.99	\$ 4,243.76	27%
27	Accident Repair	\$ 26,369.00	\$ 2,197.42	\$ -	\$ 6,592.25	\$ -	\$ 6,592.25	100%
28	Tools	\$ 750.00	\$ 62.50	\$ -	\$ 187.50	\$ 250.00	\$ (62.50)	-33%
29	Consulting	\$ 1,000.00	\$ 83.33	\$ -	\$ 250.00	\$ -	\$ 250.00	100%
30	Shop Supplies	\$ 1,000.00	\$ 83.33	\$ 21.66	\$ 250.00	\$ 370.88	\$ (120.88)	-48%
31	Facility Supplies	\$ 6,022.00	\$ 501.83	\$ 904.79	\$ 1,505.50	\$ 1,944.85	\$ (439.35)	-29%
32	Training/Meetings	\$ 6,174.00	\$ 514.50	\$ 124.99	\$ 1,543.50	\$ 124.99	\$ 1,418.51	92%
33	Shelter Maintenance	\$ 2,784.00	\$ 232.00	\$ -	\$ 696.00	\$ -	\$ 696.00	100%
34	CNG Stations Maint.	\$ 115,874.00	\$ 9,656.17	\$ 4,113.50	\$ 28,968.50	\$ 13,975.83	\$ 14,992.67	52%
35	Total Maintenance	\$ 772,079.00	\$ 61,953.86	\$ 53,185.07	\$ 185,861.58	\$ 151,577.33	\$ 34,284.25	18%
Operations Expense								
36	Mgmt/Supv Salaries	\$ 195,524.00	\$ 15,040.31	\$ 15,895.28	\$ 45,120.92	\$ 44,794.08	\$ 326.84	1%
37	Operator Wages	\$ 1,437,485.00	\$ 110,575.77	\$ 108,196.40	\$ 331,727.31	\$ 324,004.51	\$ 7,722.80	2%
38	Dispatch Wages	\$ 269,928.00	\$ 20,763.69	\$ 19,297.15	\$ 62,291.08	\$ 60,414.10	\$ 1,876.98	3%
39	Payroll Taxes	\$ 45,670.00	\$ 3,513.08	\$ 2,265.42	\$ 10,539.23	\$ 6,637.24	\$ 3,901.99	37%
40	Health & Welfare	\$ 280,831.00	\$ 23,402.58	\$ 20,320.13	\$ 70,207.75	\$ 70,100.82	\$ 106.93	0%
41	Retirement:PERS	\$ 262,886.00	\$ 20,222.00	\$ 21,057.42	\$ 60,666.00	\$ 62,638.11	\$ (1,972.11)	-3%
42	Safety Incentive Program	\$ 12,900.00	\$ 1,075.00	\$ -	\$ 3,225.00	\$ 4,100.00	\$ (875.00)	-27%
43	Workers'Comp	\$ 217,350.00	\$ 18,112.50	\$ 15,518.67	\$ 54,337.50	\$ 46,556.01	\$ 7,781.49	14%
44	Other Employee Exp.	\$ 36,409.00	\$ 3,034.08	\$ 6,900.91	\$ 9,102.25	\$ 9,952.45	\$ (850.20)	-9%
45	Mileage	\$ 1,850.00	\$ 154.17	\$ -	\$ 462.50	\$ -	\$ 462.50	100%
46	Uniforms	\$ 8,076.00	\$ 673.00	\$ 1,181.75	\$ 2,019.00	\$ 1,614.34	\$ 404.66	20%
47	Outside Services	\$ 16,635.00	\$ 1,386.25	\$ 156.00	\$ 4,158.75	\$ 322.00	\$ 3,836.75	92%
48	Tel/Cell/Internet/Fax	\$ 53,638.00	\$ 4,469.83	\$ 4,509.73	\$ 13,409.50	\$ 11,408.57	\$ 2,000.93	15%
49	Radio Expense	\$ 5,935.00	\$ 494.58	\$ -	\$ 1,483.75	\$ 780.00	\$ 703.75	47%
50	Fuel	\$ 336,885.00	\$ 28,073.75	\$ 20,506.71	\$ 84,221.25	\$ 61,408.43	\$ 22,812.82	27%
51	Trainings/Meetings	\$ 4,400.00	\$ 366.67	\$ -	\$ 1,100.00	\$ 1,038.51	\$ 61.49	6%
52	Insurance	\$ 398,598.00	\$ 33,216.50	\$ 23,846.12	\$ 99,649.50	\$ 72,414.36	\$ 27,235.14	27%
53	Deferred Comp Match	\$ 51,080.00	\$ 3,929.23	\$ 4,199.24	\$ 11,787.69	\$ 12,397.72	\$ (610.03)	-5%
54	Total Operations	\$ 3,636,081.00	\$ 288,502.99	\$ 263,850.93	\$ 865,508.98	\$ 790,581.25	\$ 74,927.73	9%
55	Grand Total of Op Exp	\$ 5,271,622.00	\$ 420,263.30	\$ 369,755.22	\$ 1,260,089.90	\$ 1,142,244.13	\$ 117,845.77	9%

BASIN TRANSIT
Statement of Income
For Period Ending 9/30/2024

Other Revenue		SEPTEMBER			YTD Bdgt	YTD Actual		
1	Interest	\$ 39,476.00	\$ 3,289.67	\$ 236.46	\$ 9,869.00	\$ 38,937.87	\$ 29,068.87	295%
2	Other Revenue	\$ 24,195.00	\$ 2,016.25	\$ 472.07	\$ 6,048.75	\$ 903.81	\$ (5,144.94)	-85%
3	CNG Fuel	\$ 106,837.00	\$ 8,903.08	\$ 1,986.98	\$ 26,709.25	\$ 10,969.74	\$ (15,739.51)	-59%
4	Renewable Gas Credits	\$ 60,093.00	\$ 5,007.75	\$ 5,515.53	\$ 15,023.25	\$ 18,065.08	\$ 3,041.83	20%
5	Insurance	\$ -	\$ -	\$ -	\$ -	\$ -	\$ -	100%
6	Gain on Sale of Assets	\$ -	\$ -	\$ -	\$ -	\$ -	\$ -	100%
7	Total Other Revenue	\$ 230,601.00	\$ 19,216.75	\$ 8,211.04	\$ 57,650.25	\$ 68,876.50	\$ 11,226.25	19%

Passenger Fares		SEPTEMBER			YTD Bdgt	YTD Actual		
8	Fixed Route	\$ 179,543.00	\$ 14,961.92	\$ 21,038.63	\$ 44,885.75	\$ 59,729.35	\$ 14,843.60	33%
9	Ready Ride	\$ 19,676.00	\$ 1,639.67	\$ 785.27	\$ 4,919.00	\$ 15,762.44	\$ 10,843.44	220%
9	Palm Spr./Palm Des.	\$ 46,731.00	\$ 3,894.25	\$ 3,572.79	\$ 11,682.75	\$ 9,558.60	\$ (2,124.15)	-18%
10	LCTOP FY24/25 K-12 and 35 Days Free Fare Promotion	\$ 45,000.00	\$ 3,750.00	\$ -	\$ 11,250.00	\$ 7,478.50	\$ (3,771.50)	-34%
11	Total Fare Revenue	\$ 290,950.00	\$ 24,245.83	\$ 25,396.69	\$ 72,737.50	\$ 92,528.89	\$ 19,791.39	27%

Current Support Funding - Operations		Grant Amt	Received	Received in Previous FY(s)	Received Current FY	Balance Due
12	Local Transit Funds	\$ 4,001,456.00	\$ -	\$ -	\$ 1,000,364.00	\$ 3,001,092.00
13	Section 5311 Operating Asst	\$ 555,516.00	\$ -	\$ -	\$ -	\$ 555,516.00
14	Measure I	\$ 153,100.00	\$ -	\$ 14,816.13	\$ 44,004.17	\$ 109,095.83
16	AB 2766	\$ 40,000.00	\$ -	\$ -	\$ -	\$ 40,000.00
17	Total Sup. Fund.Ops	\$4,750,072.00	\$ -	\$ 14,816.13	\$ 1,044,368.17	\$ 3,705,703.83

18	Total Operating Revenues	\$ 5,271,622.00	\$ 48,423.86	\$ 1,205,773.56	\$ 3,736,721.47
----	---------------------------------	------------------------	---------------------	------------------------	------------------------

Prior Year Support Funding - Operations		Grant Amt	Received	Received in Previous FY(s)	Received Current FY	Balance Due
19	Section 5311 Operating Asst FY23	\$ 579,901.00	\$ -	\$ -	\$ -	\$ 579,901.00
20	Total Prior Year Operating Revenues	\$ 579,901.00	\$ -	\$ -	\$ -	\$ 579,901.00

Current Year Capital Funding - Capital		Grant Amt	Received	Received in Previous FY(s)	Received Current FY	Balance Due
21	Operations Support Equip	\$ 50,000.00				\$ 50,000.00
22	CERBT / CEPPT Trust	\$ 290,388.00			\$ -	\$ 290,388.00
23	Engine Overhauls	\$ 50,000.00				\$ 50,000.00
24	Vehicle Replacements	\$ 1,164,329.00				\$ 1,164,329.00
25	Intelligent Transit System (ITS)	\$ 900,000.00				\$ 900,000.00
26	Short Range Transit Plan (SRTP)	\$ 100,000.00				\$ 100,000.00
27	Zero Emission RFP	\$ 246,734.00				\$ 246,734.00
28	Facilities	\$ 84,081.00				\$ 84,081.00
29	Bus Stop Improvements/PV Stops	\$ 219,440.00				\$ 219,440.00
30	Total Current Capital Funding	\$ 3,104,972.00	\$ -	\$ -	\$ -	\$ 3,104,972.00

Previous Year(s) Capital Funding - Capital		Grant Amt	Received	Received in Previous FY(s)	Received Current FY	Balance Due
31	29Palms CNG Station	\$ 130,000.00				\$ 130,000.00
32	AVL/GPS Equipment	\$ 6,000.00				\$ 6,000.00
33	AVL/GPS Equipment	\$ 85,000.00				\$ 85,000.00
35	Bus Stop Improvements	\$ 70,000.00		\$ 16,473.85		\$ 53,526.15
34	Bus Stop Improvements	\$ 17,403.00				\$ 17,403.00
36	Bus Stop Improvements	\$ 357,252.00		\$ 313,182.65	\$ 20,033.75	\$ 24,035.60
36	Bus Stop Improvements	\$ 178,508.00		\$ 137,616.00		\$ 40,892.00
37	Bus Wash System	\$ 67,950.00		\$ 4,310.00		\$ 63,640.00
38	Bus Wash System	\$ 7,500.00				\$ 7,500.00
39	CERBT / CEPPT Trust	\$ 290,388.00		\$ 145,194.00	\$ 72,597.00	\$ 72,597.00
40	CNG Compressor	\$ 650,000.00				\$ 650,000.00
41	Cost Allocation Study	\$ 20,000.00		\$ 17,481.00		\$ 2,519.00
42	Engine Overhauls	\$ 75,000.00		\$ 51,470.23		\$ 23,529.77
43	Facilities	\$ 150,000.00		\$ 103,013.79	\$ 6,212.53	\$ 40,773.68
44	Facilities	\$ 1,012,587.00			\$ 3,187.47	\$ 1,009,399.53
45	Fare Media Structure	\$ 50,000.00				\$ 50,000.00
46	Intelligent Transit System (ITS)	\$ 439,000.00	\$ 30,058.02	\$ 97,903.98	\$ 30,058.02	\$ 311,038.00
47	Operations Support Equip	\$ 50,000.00		\$ 25,160.69	\$ 4,647.70	\$ 20,191.61
48	REI Equipment	\$ 760.00				\$ 760.00
49	Short Range Transit Plan	\$ 107,000.00		\$ 87,770.10		\$ 19,229.90
50	Staff Vehicles Replacemen	\$ 50,000.00		\$ 49,812.68		\$ 187.32
51	Vehicles Replacements: 1 Class E	\$ 68,368.00		\$ 2,385.95		\$ 65,982.05
52	Vehicle Replacements	\$ 287,076.00				\$ 287,076.00
53	Vehicle Replacements	\$ 1,079,970.00			\$ 198,972.45	\$ 880,997.55
54	Vehicle Replacements	\$ 823,183.00				\$ 823,183.00
55	Zero Emission Projects	\$ 369,937.22		\$ 24,060.00		\$ 345,877.22
56	Total Prior Capital Funding	\$6,442,882.22	\$30,058.02	\$1,051,774.92	\$335,708.92	\$5,031,338.38

BASIN TRANSIT

TO: Board of Directors
FROM: Michal Brock, Office Manager
DATE: November 21, 2024

RE: Taxi Report

August 2024		September 2024	
Cab Companies:	2	Cab Companies:	2
Registered Cabs:	3	Registered Cabs:	3
Registered Drivers:	4	Registered Drivers:	4
New Driver Permits:	0	New Driver Permits:	0
Driver Permit Renewals:	0	Driver Permit Renewals:	0
Denied Business Applications:	0	Denied Business Applications:	0

Fiscal-Year-to-Date 2024/25 Taxi Administration Financial Summary

- As of September 30, 2024, expenditures are \$484.17 or 22% under the FYTD budget.
- As of September 30, 2024, revenues are \$135.00 or 13% under the FYTD budget.
- The net FYTD operating gain (loss) after expenses is (\$818.33).

STAFF RECOMMENDATION: RECEIVE AND FILE

MORONGO BASIN TRANSIT AUTHORITY
TAXI ADMINISTRATION
Statement of Expenditures
During Fiscal Year ending 6/30/25
For Period ending 8/31/2024

Line		FY 24/25	MONTH	AUGUST	Year to Date		Year to Date	
		Budget	Budget	Actual	Budget	Actual	Variance	%
	Administrative Exp.							
1	Legal Expenses	\$ -	\$ -	\$ -	\$ -	\$ -	\$ -	0%
2	Insurance	\$ 1,200.00	\$ 100.00	\$ 100.00	\$ 200.00	\$ 200.00	\$ -	0%
3	Taxicab Administrator	\$ 2,300.00	\$ 191.67	\$ 122.78	\$ 383.33	\$ 460.43	\$ 77.10	20%
4	Office Clerk	\$ 2,000.00	\$ 166.67	\$ -	\$ 333.33	\$ -	\$ (333.33)	-100%
5	Drug & Alcohol Testing	\$ 360.00	\$ 30.00	\$ -	\$ 60.00	\$ -	\$ (60.00)	-100%
6	Background Checks	\$ 128.00	\$ 10.67	\$ -	\$ 21.33	\$ -	\$ (21.33)	-100%
7	Printing/Office/Meters	\$ 422.00	\$ 35.17	\$ 36.00	\$ 70.33	\$ 72.00	\$ 1.67	2%
8	Rent & Utilities	\$ 2,400.00	\$ 200.00	\$ 200.00	\$ 400.00	\$ 400.00	\$ -	0%
9	Total Administrative Exp.	\$ 8,810.00	\$ 734.17	\$ 458.78	\$ 1,468.33	\$ 1,132.43	\$ (335.90)	-23%

MORONGO BASIN TRANSIT AUTHORITY
TAXI ADMINISTRATION
Statement of Income

Line		FY 24/25	MONTH	AUGUST	Year to Date		Variance	%
		Budget	Budget	Actual	Budget	Actual		
	REVENUE							
10	Taxi Business Permit	\$ 20.00	\$ -	\$ -		\$ -	\$ -	100%
11	Driver Permit Fees	\$ 200.00	\$ 16.67	\$ -	\$ 33.33	\$ -	\$ (33.33)	-100%
12	Vehicles Permit Fees	\$ 3,600.00	\$ 300.00	\$ 300.00	\$ 600.00	\$ 700.00	\$ 100.00	17%
13	Driver Renewal Fees	\$ 240.00	\$ 20.00	\$ -	\$ 40.00	\$ -	\$ (40.00)	-100%
14	Transfer Fees	\$ -	\$ -	\$ -	\$ -	\$ -	\$ -	100%
15	Fines	\$ 100.00	\$ 8.33	\$ -	\$ 16.67	\$ -	\$ (16.67)	-100%
16	TOTAL REVENUE	\$ 4,140.00	\$ 345.00	\$ 300.00	\$ 690.00	\$ 700.00	\$ 10.00	1%

\$ (432.43)

MORONGO BASIN TRANSIT AUTHORITY
TAXI ADMINISTRATION
Statement of Expenditures
During Fiscal Year ending 6/30/25
For Period ending 9/30/2024

Line		FY 24/25	MONTH	SEPTEMBER	Year to Date		Year to Date	
		Budget	Budget	Actual	Budget	Actual	Variance	%
	Administrative Exp.							
1	Legal Expenses	\$ -	\$ -	\$ -	\$ -	\$ -	\$ -	0%
2	Insurance	\$ 1,200.00	\$ 100.00	\$ 100.00	\$ 300.00	\$ 300.00	\$ -	0%
3	Taxicab Administrator	\$ 2,300.00	\$ 191.67	\$ 209.90	\$ 575.00	\$ 670.33	\$ 95.33	17%
4	Office Clerk	\$ 2,000.00	\$ 166.67	\$ -	\$ 500.00	\$ -	\$ (500.00)	-100%
5	Drug & Alcohol Testing	\$ 360.00	\$ 30.00	\$ -	\$ 90.00	\$ -	\$ (90.00)	-100%
6	Background Checks	\$ 128.00	\$ 10.67	\$ -	\$ 32.00	\$ -	\$ (32.00)	-100%
7	Printing/Office/Meters	\$ 422.00	\$ 35.17	\$ 76.00	\$ 105.50	\$ 148.00	\$ 42.50	40%
8	Rent & Utilities	\$ 2,400.00	\$ 200.00	\$ 200.00	\$ 600.00	\$ 600.00	\$ -	0%
9	Total Administrative Exp.	\$ 8,810.00	\$ 734.17	\$ 585.90	\$ 2,202.50	\$ 1,718.33	\$ (484.17)	-22%

MORONGO BASIN TRANSIT AUTHORITY
TAXI ADMINISTRATION
Statement of Income

Line		FY 24/25	MONTH	SEPTEMBER	Year to Date		Variance	%
		Budget	Budget	Actual	Budget	Actual		
	REVENUE							
10	Taxi Business Permit	\$ 20.00	\$ -	\$ -		\$ -	\$ -	100%
11	Driver Permit Fees	\$ 200.00	\$ 16.67	\$ -	\$ 50.00	\$ -	\$ (50.00)	-100%
12	Vehicles Permit Fees	\$ 3,600.00	\$ 300.00	\$ 200.00	\$ 900.00	\$ 900.00	\$ -	0%
13	Driver Renewal Fees	\$ 240.00	\$ 20.00	\$ -	\$ 60.00	\$ -	\$ (60.00)	-100%
14	Transfer Fees	\$ -	\$ -	\$ -	\$ -	\$ -	\$ -	100%
15	Fines	\$ 100.00	\$ 8.33	\$ -	\$ 25.00	\$ -	\$ (25.00)	-100%
16	TOTAL REVENUE	\$ 4,140.00	\$ 345.00	\$ 200.00	\$ 1,035.00	\$ 900.00	\$ (135.00)	-13%

\$ (818.33)

BASIN TRANSIT

TO: Board of Directors
FROM: Cheri Holsclaw, General Manager
DATE: November 21, 2024

RE: General Manager's Report

STAFF RECOMMENDATION: RECEIVE AND FILE



General Manager's Report

November 2024

CAPITAL PROJECTS

- GMV began installing technology on the buses on November 5th, with plans to complete installations on all buses by the end of November. Drivers and dispatchers participated in a training session on the technology on Saturday, November 16th. Meanwhile, management and the Safety & Training Supervisor have undergone multiple training sessions throughout October and November to ensure a smooth transition and effective implementation.
- The Short Range Transit Plan has been an ongoing effort aimed at enhancing public transportation throughout the Morongo Basin. Over the last couple of months, numerous community outreach events have been conducted to gather valuable input from seniors, residents, and commuters.

ACTIVITIES

- Basin Transit passed out over 65 lbs of candy at the Trunk or Treat at Copper Mountain College.
- Staff participated in the Community Health & Resource Fair at Freedom Plaza on October 12th.
- MCAGCC personnel met with Cheri and Matt to discuss the feasibility and potential impacts of dismantling their CNG station.
- Twentynine Palms City Manager, Stone James, was given a tour of the facilities.



PROCUREMENT

Purchasing activity remains strong. Orders have been placed by Cities of Wasco, Taft and Camarillo (2 orders), Counties of Stanislaus, Lassen and Sonoma as well as the Riverside Transit Authority, Omnitrans, Golden Gate Transit and Access Los Angeles (6 orders) and Able Arts and New Horizon (nonprofits).

Contract extensions were made to Creative Bus Sales and AZ Bus Sales as well as Tolar Shelters, three of our most commonly used contracts.

BASIN TRANSIT

TO: Board of Directors
FROM: Matthew Atkins, Operations Manager
DATE: November 21, 2024

RE: Operations Report

STAFF RECOMMENDATION: RECEIVE AND FILE



Operations Report

November 21, 2024

PERSONNEL

Staffing

Total Coach Operators: August - 23, September - 26

Total Dispatchers: August - 4, September - 4

Overtime

Operators: August – 4.41%, September – 4.44%

Dispatchers: August – 7.26%, September – 5.63%

OPERATIONS/ SAFETY/ CUSTOMER SERVICE

On-time performance for the reporting period:

Ready Ride: August – 97.7%, September – 99.2%

Fixed Route: August – 93%, September – 92%

Staff received three (3) customer contacts for August and September. Two (2) contacts were recorded as complaints about drivers and one (1) contact was recorded as a compliment about two (2) drivers and the dispatch team. Both complaints have been addressed with customer follow-up and the compliments were shared with the employees.

As of September 30, 2024, staff completed 154 days free of any preventable accidents and /or injuries.

EMPLOYEE TRAINING/RECRUITMENT

Operations and Training staff have scheduled three (3) new Coach Operators to start training on November 25th.

MAINTENANCE

The following is the maintenance mileage, road call and cost per mile information for August and September.



August: 4 road calls with 0 tows

Mileage: 59,414 with a CPM (cost per mile) of \$0.77

September: 3 road calls with 1 tow

Mileage: 56,880 with a CPM (cost per mile) of \$0.98

BASIN TRANSIT

TO: Board of Directors
FROM: Cheri Holsclaw, General Manager
DATE: November 21, 2024

RE: Transit Operating, Capital Plan (TOCP) Reallocation

Staff requests authorization to reallocate surplus funds from the FY 2017/18 CNG Station project. Because of the significant delay in receiving our new buses, older buses that have exceeded their useful life require engine overhauls to remain operational.

- Reallocate \$109,422.66 from LTF L18-MBT-17 CNG Station to go towards Engine Overhauls

**STAFF RECOMMENDATION: APPROVE TOCP REALLOCATION;
AUTHORIZE STAFF TO FILE TRANSIT CLAIM**

BASIN TRANSIT

TO: Board of Directors
FROM: Cheri Holsclaw, General Manager
DATE: November 21, 2024

RE: End-of-Year Employee Recognition

In the past, the General Manager acknowledged the dedication and hard work of all Basin Transit employees by hosting an annual dinner and providing a \$100 check as a token of gratitude for their contributions. Staff would like to preserve this tradition.

STAFF RECOMMENDATION: APPROVE \$100 END-OF-YEAR RECOGNITION CHECK TO EACH BASIN TRANSIT EMPLOYEE

BASIN TRANSIT

TO: Board of Directors
FROM: Cheri Holsclaw, General Manager
DATE: November 21, 2024

RE: Short Range Transit Plan (SRTP)

Presentation by Jarrett Walker + Associates.

STAFF RECOMMENDATION: DISCUSS AS NECESSARY

BASIN TRANSIT

TO: Board of Directors
FROM: Cheri Holsclaw, General Manager
DATE: November 21, 2024

RE: 35-Year Anniversary Update

Between October 1, 2024 and November 4, 2024, Basin Transit provided 24,794 free rides thanks to the Low Carbon Transit Operations Program (LCTOP). This was a 5,166 rider increase from the same time period in 2023.

STAFF RECOMMENDATION: DISCUSS AS NECESSARY

BASIN TRANSIT

TO: Board of Directors
FROM: Cheri Holsclaw, General Manager
DATE: November 21, 2024

RE: Bus Stop Improvement IFB #24-01

Staff is requesting approval to proceed with IFB #24-01. This project involves providing the necessary labor, equipment, and materials to construct a bus turnout, asphalt curb, asphalt pavement, installing the Basin Transit bus shelter, and associated work on Highway 62 in front of the Morongo Valley Post Office.

This bus stop improvement project is entirely funded by the Low Carbon Transit Operations Program (LCTOP).

STAFF RECOMMENDATION: APPROVE IFB #24-01, BUS TURNOUT AND SHELTER; AUTHORIZE STAFF TO AWARD PROJECT TO LOWEST RESPONSIVE BIDDER



BASIN TRANSIT

*Notice to Contractors, Instructions to Bidders, Special Provisions,
Proposal & Contract for:*

BUS TURNOUT AND SHELTER

AT

SR 62 AT MORONGO VALLEY POST OFFICE

IN

SAN BERNARDINO COUNTY

(IFB 24-01)

BASIN TRANSIT

Bus Turnout and Shelter (IFB 24-01)

INDEX TO DOCUMENTS

	Section
Notice Inviting Sealed Bids	A-1 to A-2
Instructions To Bidders	B-1 to B-5
Special Provisions	C-1 to C-18
Proposal	D-1 to D-12
Performance Bond	E-1
Payment Bond	F-1 to F-2
Worker's Compensation Certificate of Insurance	G-1
Insurance Requirements	H-1
Instructions for Execution of Instruments	I-1
Contract	J-1 to J-4
Appendix:	
Caltrans Encroachment Permit	

**NOTICE INVITING SEALED BIDS
BASIN TRANSIT**

Bus Turnout and Shelter (IFB 24-01)

BIDS MUST BE RECEIVED BY: 10:00 a.m. on December 20, 2024

BIDS TO BE OPENED BY: 10:00 a.m. on December 20, 2024

PLACE OF BID RECEIPT: General Manager
Basin Transit
62405 Verbena Road
Joshua Tree, CA 92252

NOTICE IS HEREBY GIVEN that the Basin Transit, County of San Bernardino, California, will receive up to, but not later than the time set forth above, sealed contract bids for the award of a contract for the above project. All bids shall be made on the form furnished by the Basin Transit and shall be opened and publicly read aloud at the above-stated time at the place of bid receipt identified above.

Bids must be placed in a sealed package with the project name and identification number typed or clearly printed on the lower left corner of the package.

PROJECT IDENTIFICATION NAME: **Bus Turnout and Shelter (IFB 24-01)**

DESCRIPTION OF WORK: Provide necessary labor, equipment and materials to construct concrete curb and gutter, asphalt pavement, bus shelter pad, sidewalk, install Basin Transit furnished bus shelter, and associated work at SR 62 at Morongo Valley Post Office in County of San Bernardino, as specified on the drawings, and in these specifications and special provisions, and as directed by the General Manager.

ENGINEER'S ESTIMATE: \$91,000

COMPLETION OF WORK: All work shall be completed within **30 working days** following written notice to proceed from the Basin Transit.

OBTAINING BID DOCUMENTS: Contract documents for the above referenced project may be obtained at the Office of the General Manager, Basin Transit, 62405 Verbena Road, Joshua Tree, California 92252, upon payment of **\$15.00** for each set if picked up in person, or **\$35.00** if mailed. Requests for mailing shall be made two weeks minimum prior to bid opening date to the Basin Transit at (760) 366-2986. This amount is not refundable.

BID BOND: Each bid response shall be accompanied by the bid securities and attachments as required in Section B – Instructions to Bidders, in an amount not less than ten percent (10%) of the amount named in the bid.

PREVAILING WAGE RATES: Pursuant to the Labor Code of the State of California, the Director of Industrial Relations has determined the general prevailing rate of wages and employer payments for health and welfare, vacation, pension and similar purposes applicable to the work to be done. The General Prevailing Wage Determinations are available at <http://www.dir.ca.gov/OPRL/pwd/>. The Contractor to whom the contract is awarded, and the subcontractors under him must pay not less than these rates for this area to all workers employed in the execution of this contract.

CONTRACTOR'S LICENSE: In accordance with the Provisions of California Public Contract Code Section 3300, the Basin Transit has determined that the Contractor shall possess a valid Class [A] General Engineering contractor's license at the time that the contract is awarded. Failure to possess the specified

license shall render the bid as non-responsive and shall act as a bar to award of the contract to any bidder not possessing said license at the time of award.

SUBSTITUTE SECURITIES FOR RETENTION MONEYS: In accordance with Part 5 (Section 22300), Division 2 of the Public Contract Code, a contractor may substitute securities for retention moneys withheld by a public agency to ensure performance under this contract. At the request and expense of the contractor, securities equivalent to the amount withheld shall be deposited with the Basin Transit, or with a state or federally chartered bank, as the escrow agent, who shall then pay such moneys to the contractor, and upon satisfactory completion of the contract, the securities shall be returned to the Contractor.

REJECTION OF BIDS: The Basin Transit reserves the right to reject any or all bids or any parts thereof and waive any irregularities or informalities in any bid or in the bidding and to make awards in all or part in the best interest of the Basin Transit.

WITHDRAWAL OF BID: No bidder may withdraw his bid for a period of sixty (60) days after the date set for the opening bids.

DEPARTMENT OF INDUSTRIAL RELATIONS REQUIREMENTS:

- No contractor or subcontractor may be listed on a bid proposal for a public works project unless registered with the Department of Industrial Relations pursuant to Labor Code section 1725.5 [with limited exceptions from this requirement for bid purposes only under Labor Code section 1771.1(a)].
- No contractor or subcontractor may be awarded a contract for public work on a public works project unless registered with the Department of Industrial Relations pursuant to Labor Code section 1725.5.
- This project is subject to compliance monitoring and enforcement by the Department of Industrial Relations.
- Contractors and subcontractors must furnish electronic certified payroll records to the Labor Commissioner for all new projects awarded.

BASIN TRANSIT

By: 

Danny Chow
Project Engineer

Date: November 4, 2024

INSTRUCTION TO BIDDERS

FORM OF PROPOSAL: The proposal shall be made on the bidding schedule ("Proposal") herein. The proposal shall be enclosed in a sealed envelope bearing the name of the bidder and the name of the project as described under Section "A".

DELIVERY OF PROPOSALS: The proposal shall be delivered by the time and to the place stipulated in the Notice Inviting Sealed Bids. It is the bidder's sole responsibility to see that his proposal is received in proper time. Any proposal received after the scheduled closing time for receipt of proposals may be returned to the bidder unopened unless an extension has been granted by the Basin Transit. Bidders or their authorized agents are invited to be present.

MODIFICATIONS AND ALTERNATIVE PROPOSALS: Unauthorized conditions, limitations or provisos attached to a proposal will render it informal and may be cause for rejection. The complete proposal forms shall be without inter-lineations, alterations or erasures, unless each such correction is suitably authenticated by affixing in the margin immediately opposite the correction the surname or surnames of the person or persons signing the bid. No oral, telegraphic or telephonic proposals or modifications will be considered.

WITHDRAWAL OF PROPOSAL: The proposal may be withdrawn upon request by the bidder without prejudice to himself prior to, but not after the time fixed for opening of bids, provided that the request is in writing, has been executed by the bidder or his duly authorized representative, and is filed with the General Manager. No proposal may be withdrawn during the period of sixty (60) calendar days after the opening of proposals.

BIDDER'S SECURITY: Each bid shall be accompanied by a certified or cashier's check payable to the Basin Transit or a satisfactory bid bond in favor of the Basin Transit executed by the bidder as principal and a satisfactory surety company as surety, in an amount not less than ten percent (10%) of the amount named in the bid. The check or bid bond shall be given as a guarantee that the bidder shall execute the contract if it is awarded to him in conformity with the contract documents and shall provide the evidence of insurance and furnish the necessary bonds as specified in the contract documents, within fifteen (15) calendar days after written notice of the award. In case of the bidder's refusal or failure to do so, the check or bond, as the case may be, shall be forfeited to the Basin Transit. No bidder's bond will be accepted unless it conforms substantially to Section "D".

APPROXIMATE ESTIMATE: The quantities shown in the proposal form, and in the estimate included in the Special Provisions, shall be considered as approximate only, being listed therein for the purpose of serving as a general indication of the amount of work or materials to be performed or furnished, and as a basis for the comparison of bids; and the Basin Transit does not guarantee nor agree, either expressly or by implication, that the actual amount required will correspond therewith, but reserves the right to increase or decrease the amount of any item or portion of work or material to be performed or furnished, or to omit any such item or portion, in accordance with the Special Provisions or Standard Specifications, under which the work is to be constructed, without any way invalidating the contract, should such increase, decrease or omission be deemed necessary or expedient.

ADDENDA: The General Manager may, from time to time, issue addenda to the contract documents during the period of advertising for bids, for the following purposes: (a) revising Prevailing Wage Scales, or (b) clarifying, correcting or otherwise amending quantities of work under Special Provisions, plans or bid proposal.

Securers of contract documents shall be notified of, and furnished with, copies of such addenda, either by certified mail or personal delivery, during the period of advertising at no additional cost.

DISCREPANCIES IN PROPOSALS: The bidder shall set forth each item of work, in clearly legible figures, a unit or line item bid for the item in the respective spaces provided for this purpose.

In case of discrepancy between the unit price and the total set forth for the item, the unit price shall prevail, provided, however, if the amount set forth as a unit price is ambiguous, unintelligible or uncertain for any cause, or is omitted, or in the case where the unit price is the same amount as the entry in the "Total" column, then the amount set forth in the "Total" column for the item shall prevail in accordance with the following:

(1) As to lump sum items, the amount set forth in the "Total" column shall be the unit price.

(2) As to unit price items, the amount set forth in the "Total" column shall be divided by the estimated quantity for the item and the price thus obtained shall be the unit price.

In case of discrepancy between words and figures, the words shall prevail.

COMPETENCY OF BIDDERS: In selecting the lowest responsible bidder, consideration will be given not only to the financial standing, but also to the general competency of the bidder for the performance of the work covered by the proposal. To this end each proposal shall be supported by a statement of the bidder's experience on the form entitled "Information Required of Bidder" bound herein. No agreement for the work will be executed with a contractor who is not licensed in accordance with the laws of the State of California under applicable provisions of the Business and Professions Code. The licensing requirements for contractors shall apply also to subcontractors.

BIDDER'S EXAMINATION OF SITE AND CONTRACT DOCUMENTS: Bidders must satisfy themselves by personal examination of the location of the proposed work and by such other means as they may prefer as to the proposal, plans, specifications, contract form and actual conditions and requirements of the work, and shall not at any time after submission of the bid, dispute, complain, or assert that there was any misunderstanding in regard to the conditions to be encountered, the character, quality, and quantities of work to be performed and materials to be furnished, and the requirements of the proposal, plans, specifications, and the contract form. The submission of a proposal shall be considered conclusive evidence that the bidder has made such examination.

DISQUALIFICATION OF BIDDERS: No person, firm, or corporation shall be allowed to make, file or be interested in more than one bid for the same work, unless alternate bids are specifically called for. A person, firm or corporation that has submitted a subproposal to a bidder, or that has quoted prices of materials to a bidder is not hereby disqualified from submitting a subproposal or quoting prices to other bidders or making a prime proposal. If there is a reason to believe that collusion exists among the bidders, all bids will be rejected.

RETURN OF BID SECURITY: The successful bidder's proposal guarantee shall be held until the contract is executed. Bid security shall be returned to unsuccessful bidders within twenty (20) calendar days after the successful bidder has signed the contract.

AWARD OF CONTRACT: The Basin Transit reserves the right to reject any or all bids or any parts thereof or to waive any irregularities or informalities in any bid or in the bidding. The award of the contract, if made by the Basin Transit, will be to the lowest responsible and qualified bidder. The award, if made, will be within sixty (60) calendar days after the opening of the proposals; provided that the award may be made after said period if the successful bidder has not given the Basin Transit written notice of the withdrawal of his bid.

ALTERNATES: In accordance with Public Contract Code Section 20103.8(b), the lowest bid shall be the lowest total of the bid price on the base bid plus any alternative bid item(s), and also providing that pursuant to that Section, the City reserves the right to deduct from the contract any alternative bid item(s).

LISTING SUBCONTRACTORS: Each bidder shall submit a list of the proposed subcontractors on this project, as required by the Subletting and Subcontracting Fair Practices Act (Public Contract Code Sections 4100, et seq.). Forms for this purpose are furnished with the contract documents.

EXECUTION OF AGREEMENT: The bidder to whom award is made shall execute a written contract with the Basin Transit in the form included in these contract documents and shall secure all insurance and bonds as herein provided within fifteen (15) calendar days from the date of mailing of written notice of the award. Failure or refusal to enter into the agreement or to conform to any of the stipulated requirements shall be just cause for the annulment of the award and forfeiture of the bidder's security. In the event the bidder to whom an award is made fails or refuses to execute the Agreement within said time, the Basin Transit may declare the bidder's security forfeited, and it may award the work to the next lowest bidder, or may call for new bids.

If the successful bidder refuses or fails to execute the contract, the Basin Transit may award the contract to the second lowest responsible bidder. If the second lowest responsible bidder refuses to execute the contract, the Basin Transit may award the contract to the third lowest responsible bidder to execute the contract; such bidder's securities shall be likewise forfeited to the Basin Transit.

INSURANCE AND BONDS: The Contractor shall not begin work under the Agreement until it has given the Basin Transit evidence of comprehensive public liability insurance and Workers' Compensation Insurance coverage as provided in the General Provisions and Sections "G" and "H" and provided Faithful Performance and Labor and Material bonds as described in General Provisions and Sections "E" and "F".

TELEPHONES: Bidders are hereby notified that Basin Transit will not provide telephones for their use at the time of receipt of bids.

MATERIAL SUPPLIER: If the firm who is signatory on the contract is supplying materials only, a payment bond need not be furnished.

INTERPRETATION OF PLANS AND DOCUMENTS: If any person contemplating submitting a bid for the proposed contract is in doubt as to the true meaning of any part of the drawings, specifications or other contract documents, or finds discrepancies in or omissions from the drawings and specifications, he may submit to the General Manager a written request for an interpretation or correction. The person submitting the request will be responsible for its prompt delivery. Any interpretation or correction of the contract document will be made only by an Addendum duly issued, and a copy of such Addendum will be mailed or delivered to each person receiving a set of the contract documents. No oral interpretation of any provision in the contract documents shall be binding.

SALES AND/OR USE TAXES: Except as may be otherwise specifically provided herein, all sales and/or use taxes assessed by federal, state or local authorities on materials used or furnished by the Contractor in performing the work hereunder shall be paid by the Contractor.

DEPARTMENT OF INDUSTRIAL RELATIONS REQUIREMENTS:

- No contractor or subcontractor may be listed on a bid proposal for a public works project unless registered with the Department of Industrial Relations pursuant to Labor Code section 1725.5 [with limited exceptions from this requirement for bid purposes only under Labor Code section 1771.1(a)].
- No contractor or subcontractor may be awarded a contract for public work on a public works project unless registered with the Department of Industrial Relations pursuant to Labor Code section 1725.5.
- This project is subject to compliance monitoring and enforcement by the Department of Industrial Relations.
- Contractors and subcontractors must furnish electronic certified payroll records to the Labor Commissioner for all new projects awarded.

PROTEST PROCEDURES: All protests must be in writing, stating the name and address of protestor, a contact person, Contract number and title. Protests shall specify in detail the grounds of the protest and the facts supporting the protest.

ADDRESS:

All protests must be addressed as follows:

Basin Transit – Bus Turnout and Shelter (IFB 24-01)

Agency Contact: Ms. Cheri Holsclaw
For U.S. Mail, special delivery or hand delivery:
Basin Transit
62405 Verbena Road
Joshua Tree, CA 92252

Protests not properly addressed to the address shown above may not be considered by the Agency. Copies of the Agency's protest procedures and the protest provisions of FTA Circular 4220.1F or its successor may be obtained from Ms. Cheri Holsclaw, General Manager, Basin Transit, 62405 Verbena Road, Joshua Tree, CA 92252, [760-366-2986](tel:760-366-2986). Proposals shall be opened and a Notice of Award shall be issued by the Agency in accordance with the Agency's protest procedures and the protest provisions of FTA Circular 4220.1F or its successor.

PRE-PROPOSAL PROTESTS:

Pre-Proposal protests are protests based upon the content of the solicitation documents. Three copies of Pre-Proposal protests must be received by the Agency's office no later than ten (10) calendar days after the RFP is first advertised. Protests shall be considered and either denied or sustained in part or in whole, in writing, in a manner that provides verification of receipt, prior to the Due Date for Proposals. A written decision specifying the grounds for sustaining all or part of or denying the protest shall be transmitted to the protestor prior to the Due Date for Proposals in a manner that provides verification of receipt prior to the Due Date for Proposals. If the protest is sustained, the Proposal Due Date may be postponed and an addendum issued to the solicitation documents or, at the sole discretion of the Agency, the solicitation may be canceled. If the protest is denied, Proposals shall be received and opened on the scheduled date unless a protest is filed with FTA. See "FTA Review," below.

PROTESTS ON THE RECOMMENDED AWARD:

All proposers shall be notified of the recommended award. This notice shall be transmitted to each proposer at the address contained in its Proposal form in a manner that provides verification of receipt. Any Proposer whose Proposal has not lapsed may protest the recommended award on any ground not specified in "Pre-Proposal Protests," above. Three (3) copies of a full and complete written statement specifying in detail the grounds of the protest and the facts supporting the protest must be received by the Agency at the appropriate address in "Address," above, no later than fifteen (15) calendar days after the date such notification is received. Prior to the issuing of the Notice of Award, a written decision stating the grounds for allowing or denying the protest shall be transmitted to the protestor and the proposer recommended for award in a manner that provides verification of receipt.

CALTRANS REVIEW:

After such administrative remedies have been exhausted, an interested party may file a protest with the California Department of Mass Transportation pursuant to the procedures provided in the FTA C 4220.1F or its successor. Caltrans review is limited to the alleged failure of the Agency to have written protest procedures, the alleged failure of the Agency to follow those procedures, the alleged failure of the Agency to review a protest or the alleged violation of federal law or regulation.

The protest filed with Caltrans shall:

- 1) Include the name and address of the protestor.
- 2) Identify Basin Transit as the party responsible for the RFP process.
- 3) Contain a statement of the grounds for protest and any supporting documentation. (The grounds for protest filed with Caltrans must be fully supported to the extent feasible. Additional materials in support of an initial protest will only be considered if authorized by the FTA regulations.)
- 4) Include a copy of the protest filed with Basin Transit, and a copy of Basin Transit's decision, if any.
- 5) Indicate the ruling or relief desired from Caltrans.

Basin Transit – Bus Turnout and Shelter (IFB 24-01)

Such protests should be sent to:

California Department of Transportation
Division of Mass Transportation
PO BOX 942874 – M.S. 39,
Sacramento, CA 942874-0001

A copy of such protests should also be sent to the General Manager.

SPECIAL PROVISIONS

Sub - Section 1. General Provisions

The general provisions which shall apply to this contract shall be those set forth in the Standard Specifications for Public Works Construction, latest edition and Supplements, published by Building News, Inc., 3055 Overland Avenue, Los Angeles, California 90034, hereinafter referred to as "Standard Specifications." The Standard Specifications are referred to and by this reference made a part hereof as though set forth at length. The Contractor is required to comply with the Standard Specifications in addition to the conditions set forth in these General Provisions, Specific Project Provisions and as stated in the Special Provisions of these contract documents.

I. AWARD OF BID AND EXECUTION OF CONTRACT

I-A. DECISION AS TO WHICH CONTRACTOR IS THE LOWEST AND BEST BIDDER - All bidders must submit with their proposals satisfactory evidence that they are capable of performing the work in accordance with plans and specifications. The General Manager may require any bidder bidding on any public improvement to submit experience records covering a three-year period. The Basin Transit Board may reject the bid of any bidder who has been delinquent or unfaithful in the performance of any previous contract work. The decision of the Basin Transit Board as to which bidder is considered the "lowest responsible bidder" will be based not only on the actual amount of the bid, but also on the relative competence and experience of the bidders, with particular regard to the quality performance of any work done by them for the Basin Transit in the past, and such decisions shall be final and binding upon all parties.

I-B. EXECUTION OF THE CONTRACT - The contract, in the form set forth in Section "J" shall be executed by the successful bidder in accordance with the Instruction for Execution of Instruments, and returned to the Basin Transit for execution by the Basin Transit, and shall be accompanied by bonds as described in Paragraph I-C and the evidence of insurance required by Paragraph I-D, all within fifteen (15) calendar days from the date written notice of the award is mailed to bidder. No bidder proposal shall be considered binding upon the Basin Transit until such time as it has been executed by the Basin Transit.

I-C. CONTRACT BONDS - The successful bidder shall furnish to the Basin Transit at his own expense two surety bonds. One bond shall be in the amount of 100% of the contract price in the form set forth in Section "E" to guarantee faithful performance of the contract work. The other bond, in an amount not less than 100% of the contract price in the form set forth in Section "F" shall be furnished to secure payment of those supplying labor and materials as required by the California Civil Code. Each bond shall be executed in accordance with the instructions set forth in Section "I" and each bond shall be executed by a corporate surety acceptable to, and approved by the Basin Transit.

I-D. INSURANCE - The Contractor shall at all times, during the term of this contract, carry, maintain and keep in full force and effect, a policy or policies of comprehensive public liability insurance with an insurance company acceptable to, and approved by, the General Manager and Basin Transit, within minimum limits of One Million Dollars (\$1,000,000.00) combined single limit coverage against any injury, death, loss or damage as a result of wrongful or negligent acts or omissions by the Contractor, together with an endorsement in substantially the form set forth in Section "H" attached hereto. The Contractor shall also at all times during the term of this contract carry, maintain and keep in full force and effect a policy or policies of Workers' Compensation insurance and shall provide to the Basin Transit evidence of such coverage in the form set forth in Section "G" attached hereto.

I-E. COMPLIANCE WITH PROVISIONS OF THE PUBLIC CONTRACT CODE - All Contracts shall conform with the provisions of Sections 4100 through 4114, inclusive, of the Public Contract Code, as amended, concerning subcontractors and subcontracts.

I-F. REJECTION OF BIDS - Proposals may be rejected by the Basin Transit Board where, upon evidence of a prior performance of the bidder, the Basin Transit Board has made a finding that the bidder is not a

responsible contractor because of unsatisfactory performance within the past three (3) years with the Basin Transit or with other public entities. The Basin Transit reserves the right to reject any or all bids and to waive any irregularity or informality in any bid to the extent permitted by law.

II. LEGAL RELATIONS AND RESPONSIBILITY TO THE BASIN TRANSIT

II-A. LAWS TO BE OBSERVED - The Contractor shall keep himself fully informed on all existing and pending State and national laws and all municipal ordinances and regulations of the Basin Transit, which in any manner affect those employed in the work, or the material used in the work, or which in any way affect the conduct of the work, and of all such orders and decrees of bodies or tribunals having jurisdiction or authority over the same. The Contractor shall particularly observe all ordinances of the Basin Transit in relations to the obstruction of streets or conduct of the work, keeping open passageways and protecting the same where they are exposed or dangerous to traffic.

II-B. SOCIAL SECURITY REQUIREMENTS - The Contractor shall furnish to the Basin Transit satisfactory evidence that he and all subcontractors working for him are complying with all requirements of the Federal and State Social Security legislation. The Contractor, at any time on request, shall satisfy the Basin Transit that the Social Security and Withholding tax are being properly reported and paid.

II-C. PREVAILING WAGES - In accordance with the provisions of Section 1770 *et seq.*, of the Labor Code, the Director of the Department of Industrial Relations of the State of California has ascertained the general prevailing rate of wages applicable to the work to be done under contract for public improvement. The Contractor will be required to pay to all those employed on the project sums not less than the sums set forth in the documents entitled "General Prevailing Wage Determination made by the Director of Industrial Relations pursuant to California Labor Code Part 7, Chapter 1, Article 2, Sections 1770, 1773, 1773.1 and 1776."

The Contractor shall post a copy of the prevailing wage rates at each job site.

II-D. PENALTIES - The Contractor shall comply with Labor Code Section 1775 and he shall forfeit, as a penalty to the Basin Transit, the sum of not more than fifty dollars (\$50.00) as determined by the labor commissioner, for each calendar day or portion thereof during which the Contractor or any subcontractor under him has paid to any workman employed in the project an amount less than that required by the provisions of the preceding Paragraph II-C.

II-E. WORKING HOURS - The Contractor shall forfeit, as penalty to the Basin Transit, the sum of twenty-five dollars (\$25.00) for each workman employed in the execution of the contract by him or by any subcontractor under him for each calendar day during which such worker is required or permitted to work more than eight (8) hours in any one calendar day and forty (40) hours in any one calendar week, in violation of the provisions of Labor Code Section 1813.

II-F. APPRENTICES - Attention is directed to the provisions of Sections 1777.5 and 1777.6 of the Labor Code concerning the employment of apprentices by the Contractor or any subcontractor under him. It shall be Contractor's responsibility to ensure that all persons shall comply with the requirements of said sections in the employment of apprentices.

Information relative to apprenticeship standards and administration of the apprenticeship program may be obtained from the Department of Industrial Relations, San Francisco, California, or from the Division of Apprenticeship Standards and its branch offices.

II-G. REGISTRATION OF CONTRACTORS - Only a Contractor licensed in accordance with the provisions of Chapter 9, Division 3, of the Business and Professions Code, beginning at Section 7000, shall be permitted to enter into a contract with the Basin Transit for any public improvements.

II-H. PERMITS AND LICENSES - The Contractor shall procure all permits and licenses, (including a business license of the City or Town in which the project is located, if required), pay all charges and fees

and give all notices necessary and incidental to the due and lawful prosecution of the work.

II-I. PATENTS - The Contractor shall assume all responsibility arising from the use of any patented, or allegedly patented materials, equipment, devices or processes used on or incorporated in the work, and shall defend, indemnify, and hold harmless the Basin Transit, and each of its officers, agents, and employees from and against any and all liabilities, demands, claims, damages, losses, costs, and expenses, of whatsoever kind or nature, arising from such use.

II-J. INDEMNITY - The Contractor agrees to defend, indemnify, and save harmless the Basin Transit and each of its officers, agents, and employees and agents including but not limited to the firm, its officers and employees of Charles Abbott Associates, Inc. who are providing services to the Basin Transit from and against any and all liabilities, demands, claims, damages, losses, costs, and expenses, of whatsoever kind or nature, including, but not limited to, any and all direct and indirect consequence of entering into this contract or of injury, sickness, or disease, including death, to persons or injury to, or destruction of, property, including, but not limited to, the loss of use of property, resulting directly or indirectly from or in any manner connected with or pertaining to any and all operations, and any and all activities, omissions and conditions in any manner connected therewith or pertaining thereto, of the Contractor under the contract, subject to any limitations imposed by Civil Code Section 2782.

II-K. NOTICE - The address given in the Contractor's proposal is the place to which all notices to the Contractor shall be mailed or delivered. The mailing to or delivering at the above named place of any notice shall be deemed sufficient service thereof upon the Contractor, and the date of that service shall be the date of such mailing or delivery. Such address may be changed at any time by written notice signed by the Contractor and delivered to the General Manager.

II-L. CONTRACTOR'S RESPONSIBILITY FOR WORK - Until the final acceptance of the work by the Basin Transit, by written action of the General Manager, the Contractor shall have the charge and care thereof and shall bear the risk of injury or damage to any part of the work by the action of the elements or any other cause. The Contractor shall rebuild, repair, restore and make good all injuries or damages to any portion of the work occasioned by any cause before its completion and acceptance and shall bear the expense thereof, except for such injuries or damages arising from the sole negligence of willful misconduct of the Basin Transit, its officers, agents or employees. In the case of suspension of work from any cause whatever, the Contractor shall be responsible for all materials and the protection of work already completed and shall properly store and protect them if necessary and shall provide suitable drainage and erect temporary structures where necessary.

II-M. MAINTENANCE AND GUARANTEE -

(1) The Contractor hereby guarantees that the entire work constructed by him under the contract will meet fully all requirements as to quality of workmanship and materials. The Contractor hereby agrees to make at his own expense any repairs or replacements made necessary by defects in materials or workmanship that become evident within one year after the date of the final payment, and to restore to full compliance with the requirements of these specifications including any test requirements set forth herein for any part of the constructed hereunder, which during said one-year period is found to be deficient with respect to any provisions of the specifications. The Contractor shall make all repairs and replacements promptly upon receipt of written orders for the same from the General Manager.

(2) The guarantees and agreements set forth in Subsection 1 shall be secured by a surety bond which shall be delivered by the Contractor to the Basin Transit before the Notice of Completion and acceptance of the work, by the General Manager, as provided in Subsection 6-8 of the Standard Specifications. Said bond shall be in the form approved by the Basin Transit and executed by a surety company or companies satisfactory to the Basin Transit, in the amount of 100% of the contract. Said bond shall remain in force for a period of one year after the date of Notice of Completion and acceptance. Alternatively, the Contractor may provide for the Faithful Performance Bond furnished under the contract to remain in force and effect for said amount until the expiration of said one-year period.

III. PROSECUTION AND PROGRESS OF THE WORK

III-A. WORK SCHEDULE - As soon as notified of the award of the contract, the Contractor shall prepare and submit to the General Manager a work schedule for accomplishing the work. Said schedule must show the dates of the expected start and completion of the various items of the contract work. During a scheduling conference between the Contractor and the General Manager, the work schedule will be discussed and modified, if necessary, by mutual agreement. Should it become necessary for the Basin Transit to delay temporarily the work schedule agreed upon during the scheduling conference, every effort will be made to permit a new work schedule at the time most convenient to the Contractor, thus permitting the project to proceed with the shortest intramural movement of the equipment.

III-B. SUBLETTING AND ASSIGNMENT - The Contractor shall give his personal attention to the fulfillment of the contract and shall keep the work under his control. The Contractor shall not assign, transfer nor sublet any part of the work without the written consent of the Basin Transit by the General Manager and of the surety of the Contractor's bond, and such consent of Surety, together with a copy of the subcontract, shall be filed with the General Manager. No assignment, transfer or subletting, even though consented to, shall relieve the Contractor of his liabilities under the contract. Subcontractors shall not be recognized as such, and all persons engaged in the project will be considered as employees of the Contractor, their work being subject to the provisions of the contract and the specifications. Should any subcontractor fail to perform the work undertaken by him to the satisfaction of the General Manager, said subcontractor shall be removed immediately from the project upon request by the General Manager, shall not again be employed on the work, and the Contractor shall be held liable for the deficient work.

The Contractor shall submit to the Basin Transit a list with the names, addresses and telephone numbers of all subcontractors who will work under him.

III-C. CHARACTER OF WORKMAN - The Contractor shall employ none but competent foremen, laborers and mechanics. Any overseer, superintendent, laborer or other person employed on the work by the Contractor who is intemperate, incompetent, troublesome or otherwise undesirable, or who fails or refuses to perform the work in the manner specified herein, shall be discharged immediately and such person shall not again be employed on the work.

III-D. AGENTS OR FOREMAN - In the absence of the Contractor from the site of the project, even if such is only of a temporary duration, he must provide and leave at the site a competent and reliable English-speaking agent or foreman in charge. All notices, communications, orders or instructions given, sent to, or served upon, such agent or foreman by the General Manager shall be considered as having been served upon the Contractor.

III-E. TEMPORARY STOPPAGE OF CONSTRUCTION ACTIVITIES - The General Manager shall have the authority to suspend the contract work, wholly or in part, for such a period of time as he may deem necessary, due to unsuitable weather, or to such other conditions as he considered unfavorable for the proper prosecution of the work, or for such time as he may deem necessary due to failure on the part of the Contractor or his workmen to carry out orders or to perform any of the requirements of the contract. The Contractor shall immediately comply with such an order from the General Manager and shall not resume operations until so ordered in writing.

III-F. TIME OF COMPLETION AND LIQUIDATED DAMAGES - If all the contract work is not completed in all parts and requirements within the time specified in the contract documents, the Basin Transit shall have the right to grant or deny an extension of time for completion, as may seem best to serve the interest of the Basin Transit. The Contractor shall not be assessed with liquidated damages during any delay in the completion of the work caused by acts of God or of the Public Enemy, acts of the State, fire not due to acts of contractors, of subcontractors, floods, epidemics, quarantine, restrictions, strikes, freight embargo or unusually severe weather, or delays of subcontractors due to such causes, provided that the Contractor shall, within ten (10) days from the beginning of such delay, notify the Basin Transit, in writing, of the cause of the delay. The Basin Transit will ascertain the facts and the extent of the delay, and the finding thereon shall be final and conclusive. If the Basin Transit deems it appropriate to assess the contractor liquidated

damages, such damages shall be of a minimum amount of \$250.00 per day.

III-G. SUSPENSION OF CONTRACT - If at any time, in the opinion of the General Manager, the Contractor fails to supply an adequate working force, manufactured articles, or material of proper quality, or has failed in any other respect to prosecute the work with the diligence and force specified and intended in any by the terms of the contract, notice thereof in writing will be served upon him, and should he neglect or refuse to provide means for a satisfactory compliance with the contract within the time specified in said notice and as directed by the General Manager, the General Manager shall have the power to suspend the operation of the contract and discontinue all work or any part thereof, subject to review by the Basin Transit Board. Thereupon the Contractor shall discontinue such work, or such part thereof as the Basin Transit may designate, and the Basin Transit may thereupon, by contract or otherwise, as it may determine, complete the work or such part thereof, and charge the entire expense of so completing the work or any part thereof to the Contractor, and for such completion the Basin Transit itself or its Contractors may take possession of and use, or cause to be used in the completion of the work, or any part thereof, any such materials, implements and tools of every description as may be found at the place of such work. All expense charged under this paragraph shall be deducted and paid for by the Basin Transit out of any moneys then due or to become due the Contractor under the contract, or any part thereof, and in such accounting the Basin Transit shall not be held to obtain the lowest figure for the work for completing the contract, or any part thereof, or for ensuring its proper completion, but all sums paid therefore shall be charged to the Contractor. In case the expenses so charged are less than sum which would have been payable under the contract, if the same had been completed by the Contractor, the Contractor shall be entitled to receive the difference, and in case such expense shall exceed the amount payable under the contract, then the Contractor shall pay the amount of the excess to the Basin Transit, upon completion of the work, without further demand being made therefore. In the determination of the question as to whether or not there has been any such noncompliance with the contract as to warrant the suspension or annulment thereof, the decision of the Basin Transit Board shall be binding on all parties to the contract.

IV. MEASUREMENT AND PAYMENT

IV-A. MEASUREMENT AND PAYMENT - Measure of the quantities of work and payments therefore shall be in accordance with Section 9 of the Standard Specifications. In accordance with Subsection 9.2 of the Standard Specifications, the monthly payment date shall be the last calendar day of each month. A measurement of work performed and a progress estimate of the value thereof based on the contract and of the monthly payment shall be prepared by the Contractor and submitted to the General Manager before the tenth day of the following month for verification and payment consideration.

IV-B. FINAL INVOICE AND PAYMENT –

(1) Whenever in the opinion of the General Manager, the Contractor shall have completely performed the contract on his part, the General Manager shall notify the Basin Transit that the contract has been completed in its entirety. The Contractor shall then submit to the General Manager for approval, a written statement of the final quantities of contract items for inclusion in the final invoice. Upon receipt of such statement, the General Manager shall check the quantities included therein and shall authorize the Contractor to submit an invoice which in the General Manager's opinion shall be just and fair, covering the amount and value of the total amount of work done by the Contractor, less ten percent (10%) of the total work done. The General Manager shall then request that the Basin Transit accept the work and that the General Manager be authorized to file, on behalf of the Basin Transit in the office of the San Bernardino County Recorder, a Notice of Completion of the work herein agreed to be done by the Contractor.

(2) On the expiration of thirty-five (35) days after the date of recording the Notice of Completion, the Basin Transit shall pay to the Contractor the amount remaining after deducting from the amount of value stated in the invoice all prior payments to the Contractor and all amounts to be kept and retained under the provisions of the contract, and shall release the Faithful Performance Bond and Labor and Material Bond.

(3) Substitution of Securities for Retention: In accordance with Public Contract Code Section 22300, the Contractor may substitute securities for retention moneys to be withheld to ensure performance under this

contract. At the request and expense of the Contractor, securities equivalent to the amount withheld may be deposited with the Basin Transit, or with an approved state or federally chartered bank as the escrow agent, who shall then pay such moneys to the Contractor, and upon satisfactory completion of the contract, the securities shall be returned to the contractor. It is the Contractor's obligation to secure the services of a state or federally chartered bank to act as escrow agent. Securities eligible for investment include those listed in Government Code Section 16430 or bank or savings and loan certificates of deposit, interest bearing demand deposit accounts, standby letters of credit or any other security mutually agreed to by the Contractor and the Basin Transit. Contractor shall be the beneficial owner of any securities for retention moneys withheld and shall receive any interest earned by the securities.

IV-C. EXTRA WORK - Extra work, when ordered in writing by the General Manager and accepted by the Contractor, shall be paid for under written work order in accordance with the terms therein provided. Payment for extra work will be made at the unit price or lump sum previously agreed upon between the Contractor and the General Manager. All extra work shall be adjusted daily upon report sheets prepared by the General Manager, furnished by the Contractor, and signed by both parties, and said daily report shall be considered thereafter the true records of extra work done.

IV-D. UNPAID CLAIMS - If upon or before the completion of the work herein agreed to be performed or at any time prior to the expiration of the period within which claims of lien may be filed for record as prescribed by the Code of Civil Procedure of the State of California, any person or persons claiming to have performed any labor or furnished any materials, supplies or services towards the performance of completion of this contract or if they have agreed to do so, shall file with the Basin Transit a verified statement of such claim, or if any person shall bring against the Basin Transit or any of its agents any action to enforce such claim, the Basin Transit shall until the discharge thereof, withhold from the moneys that are under its control, as much as shall be sufficient to satisfy and discharge the amount in such notice or under such action claimed to be due, together with the cost thereof; provided, that if the Basin Transit shall in its discretion permit the Contractor to file such additional bond as is authorized by the Code of Civil Procedure in a penal sum equal to one and one-quarter times the amount of said claim, said money shall not thereafter be withheld on account of such claim.

IV-E. ACCEPTANCE - The parties agree that no certificate given shall be conclusive evidence of the faithful performance of the contract, either in whole or in part, and that no payment shall be construed to be in acceptance of any defective work or improper materials. Further, the certificate or final payment shall not terminate the Contractor's obligations under his warranty hereinabove. The Contractor agrees that payment of the amount due under the contract and the adjustments and payments due for any work done in accordance with any alterations of the same, shall release the Basin Transit, the Basin Transit Board and its officers and employees from any and all claims or liability on account of work performed under the contract or any alteration thereof. (Section 7100, Public Contract Code)

V. CONTROL OF WORK

V-A. AUTHORITY OF THE GENERAL MANAGER - The General Manager shall decide any and all questions that may arise as to the quality and acceptability of materials furnished and work performed as to the manner of performance and rate of progress of the work, and any and all questions which may arise as to the interpretation of the plans and specifications. The General Manager shall likewise decide any and all questions as to the acceptable fulfillment of the contract on the part of the Contractor, and all questions as to claims and compensations. The decision of the General Manager shall be final, and he shall have relative authority to enforce and make effective such decisions and actions as the Contractor fails to carry out promptly.

V-B. CONFORMITY WITH PLANS AND ALLOWABLE VARIATION - Finished surfaces shall in all cases conform with the lines, grades, cross-sections and dimensions shown on the plans. Minor deviations from approved plans, whenever required by the exigencies of construction, shall be determined in all cases by the General Manager and authorized in writing.

V-C. PROGRESS OF THE WORK - The Contractor shall begin work on the date agreed upon following

the scheduling conference mentioned in Paragraph III-A hereof, and shall diligently prosecute the same to completion before the expiration of the time limit appearing in the specifications.

V-D. SAMPLES - The Contractor shall furnish all products and materials required to complete the work. All materials and products must be of the specified quality and fully equal to samples, when samples are required. Whenever required, the Contractor shall submit to the General Manager for test, and free of charge, samples of any one of the materials or products proposed to be used in the work. Said samples shall be delivered by the Contractor to the place within the Basin Transit designated by the General Manager. Rejected material must be immediately removed from the work by the Contractor and shall not again be brought back to the site.

V-E. TRADE NAMES AND ALTERNATIVES - For convenience in designation on the plans or in the specifications, certain equipment or articles or materials to be incorporated in the work may be designated under a trade name of manufacturer and his catalog information. The use of an alternative equipment or an article or equipment which is of equal quality and of the required characteristics for the purpose intended will be permitted, subject to the approval of the General Manager, in accordance with the following required by Section 3400 of the Public Contract Code of the State of California.

The burden of proof as to the comparative quality and suitability of alternative equipment or articles or materials shall be upon the Contractor, and he shall furnish, at his own expense, all information necessary or related thereto as required by the General Manager. The General Manager shall be the sole judge as to the comparative quality and suitability of alternative equipment or articles or materials and his decision shall be final. All requests for substitution shall be submitted seven (7) days in advance of bid opening to permit, if the request is approved, an addendum to be issued to all bidders.

V-F. PROTECTION OF WORK - The Contractor shall continuously maintain adequate protection of all his work from damage, and the Basin Transit will not be held responsible for the care or protection of any material, equipment or parts of work, except as expressly provided for in the specifications.

V-G. CONFLICT OF TERMS - The notice to bidders, proposal, plans, specifications and General Provisions are essential parts of the contract for a given project. These documents, together with the necessary bonds and bidder's guarantee, constitute the contract as defined herein, and a requirement included in one document shall be as binding as though included in all, as they are intended to be cooperative and to provide a description of the work to be done. Should there be any conflict or discrepancy between terms used, then the specifications shall govern over plans, and change orders and supplemental agreements shall govern over any other contract document.

V-H. INTERPRETATION OF PLANS AND SPECIFICATIONS - Should it appear that the work to be done, or any matter relative thereto, is not sufficiently detailed or explained on the plans or in the specifications, the Contractor shall request the General Manager for such further explanation as may be necessary, and shall conform to such explanation or interpretation as part of the contract, so far as may be consistent with the intent of the original specifications. In the event of doubt of questions relative to the true meaning of the specifications, reference shall be made to the Basin Transit Board, whose decision thereon shall be final.

V-I. ALTERATIONS, INCREASES AND DECREASES OF WORK TO BE DONE - The Basin Transit reserves the right to increase or decrease the quantity of any item or portion of the work described on the plans, the specifications or the proposal form or to omit portions of the work so described, as may be deemed necessary or expedient by the General Manager and the Contractor shall agree not to claim or bring suit for damages, whether for loss of profits or otherwise, on account of any decrease or omission of any kind of work to be done. By mutual consent of the parties signatory to the contract, alterations, modifications or deviations from the type of work may be described on the plans, specifications or on the proposal form may be made without in any way making the contract void. The price to be paid by the Basin Transit to the Contractor for such altered or modified work shall be agreed upon in writing, endorsed upon the original contract and signed by the proper parties to said contract.

Whenever, during the progress of the work, such changes or modifications are deemed necessary by the General Manager and agreed upon, as aforesaid, said deviations shall be considered and treated as though originally contracted for, and shall be subject to all the terms, conditions and provisions of the original contract.

V-J. EXTRA WORK - New and unforeseen work will be classed as extra work only when said work is not covered and cannot be paid for under any of the various items or combination of items for which a bid price appears on the proposal form. The Contractor shall not do any extra work except upon written order from the General Manager. Compensation for such extra work shall be previously agreed upon in writing between the Contractor and the General Manager.

V-K. LINES AND GRADES - Except when, as per orders from the General Manager, minor changes in the work are to be made by the Contractor, all work shall, during its progress and upon completion, conform to the lines, grades and elevations shown on the plans. All distances and measurements are given thereon and will be made in a horizontal plane. Three (3) consecutive points shown on the same rate of slope must be used in common in order to detect any variation from a straight line, and in case any such discrepancy exists, it must be reported to the General Manager. Failure to make this report shall make the Contractor responsible for any error in the finished work.

V-L. PUBLIC UTILITIES -

(1) All of the existing utility facilities except those to be relocated as shown on the plans will remain in place and the contractor will be required to work around said facilities. In case it should be necessary to remove the property of a public utility or franchise, such owner will, upon proper application by the Contractor, be notified by the General Manager to move such property within a reasonable time, and the Contractor shall not interfere with said property until after the expiration of the time specified. The right is reserved to the owners of public utilities or franchises to enter upon the streets for the purpose of making repairs or changes in their property which may be necessary as a result of the work. Employees and agents of the Basin Transit shall likewise have the privilege of entering upon the street for the purpose of making any necessary repairs or replacements.

(2) The Contractor shall employ and use only qualified persons, as hereinafter defined, to work in proximity to Southern California Edison secondary, primary and transition facilities. The term "qualified person" shall mean one, who by reason of experience or instruction, is familiar with the operation to be formed and the hazards involved, as more specifically defined in Section 2700 of Title 8 of the California Administrative Code. The Contractor shall take such steps as are necessary to assure compliance by any subcontractors.

V-M. REMOVAL OF INTERFERING OBSTRUCTIONS - The Contractor shall remove and dispose of all debris, abandoned structures, tree roots and obstructions of any character met during the process of excavation, it being understood that the cost of said removals are made a part of the unit price bid by the Contractor under the item for excavation or removal of existing work.

V-N. PROCEDURE IN CASE OF DAMAGE TO PUBLIC PROPERTY - Any portions of curb, gutter, sidewalk or any other Basin Transit improvement damaged by the Contractor during the course of construction shall be replaced by the Contractor at his own cost, free of charges to the Basin Transit. The cost of additional replacement of curb, gutter or sidewalk in excess of the estimated quantities shown in the proposal form and specifications, and found necessary during the process of construction, (but not due to damage resulting from carelessness on the part of the Contractor during his operation), shall be paid to the Contractor at the unit prices submitted in his bid.

V-O. AVOIDANCE OF DUST NUISANCE - During the process of breaking, excavating and removing any material from the site of the project and until completion of the work, the Contractor shall take every precaution to avoid the nuisance of unnecessary dust by using any measures advocated by the General Manager.

V-P. REMOVAL OF DEFECTIVE OR UNAUTHORIZED WORK - It is the intent of the specifications that

only first-class work, materials and workmanship will be acceptable. All work which is defective in its construction or deficient in any of the requirements of the specifications shall be remedied, or removed and replaced by the Contractor in an acceptable manner, and no compensation will be allowed for such correction. Any work done beyond the lines shown on the plans or established by the General Manager, or any extra work done without written authority will be considered as unauthorized and will not be paid for. Upon failure on the part of the Contractor to comply forthwith with any order of the General Manager made under the provisions of this paragraph, the General Manager shall have authority to cause defective work to be remedied or removed and replaced, and unauthorized work to be removed, and to deduct the costs thereof from any moneys due or to become due the Contractor. If the work is found to be in compliance with these specifications, the General Manager will furnish the Contractor with a certificate to that effect.

V-Q. SUPERVISION - All manufactured products, materials and appliances used and installed and all details of the work shall at all times be subject to the supervision, test and approval of the General Manager or his authorized representatives. The General Manager or his authorized representatives shall have access to the work at all times during construction, and shall be furnished with every reasonable facility for securing full knowledge with regard to the progress, workmanship and character of the materials used or employed in the work.

Whenever the Contractor varies the period during which work is carried on each day, he shall give adequate notice to the General Manager so that proper inspection may be provided. Any work done in the absence of the General Manager or the General Manager's agent will be subject to rejection. The inspection of the work shall not relieve the Contractor of any of his obligations to fulfill the contract as prescribed. Defective work shall be made good, and unsuitable materials may be rejected, notwithstanding the fact that such defective work and unsuitable materials have previously been accepted or estimated for payment.

The Contractor shall prosecute work on any State highway or with any railroad right-of-way only in the presence of an inspector representing the State Division of Highways or the railroad company, and any work done in the absence of such inspectors will be subject to rejection. The Contractor shall make the appropriate notification according to the instructions given on the State Encroachment Permit or railroad permit for all inspections, and shall post all bonds and certificates required by the permit. The permit shall be acquired by the Contractor at the Contractor's expense. The Contractor shall pay for all testing and inspections required by a State Encroachment Permit or railroad permit.

V-R. QUALITY OF MATERIAL - Materials shall be new, and of specified kind and quality, and fully equal to samples when samples are required. When the quality or kind of material or articles shown required under the contract is not particularly specified, the Contractor shall estimate that the Basin Transit will require articles and materials representing the best of their class or kind or at least equal to the class or quality of similar articles or materials when specified. Materials shall be furnished in such quantities and kinds and at such times as to ensure uninterrupted progress for the work. They shall be stored properly and protected as required. The Contractor shall be entirely responsible for damage or loss by weather or any other cause.

V-S. DEFECTIVE MATERIALS - All materials not conforming to the requirements of these specifications shall be considered as defective, and all such materials shall be removed immediately from the site of the work unless otherwise permitted by the General Manager. Upon failure on the part of the Contractor to comply with any order by the General Manager made under the provisions of this article, the General Manager shall have the authority to remove and replace defective material and to deduct the cost of removal and replacement from any moneys due or to become due to the Contractor.

V-T. SOUND AND VIBRATION CONTROL REQUIREMENTS - The Contractor shall comply with all local sound control and noise level rules, regulations and ordinances. No internal combustion engine shall operate on the project without a muffler of the type recommended by the manufacturer. Should any muffler or other control device sustain damage, the Contractor shall promptly remove the equipment and shall not return said equipment to the job until the device is repaired or replaced. Said noise and vibration level requirements shall apply to all equipment on the job or related to the job, including, but not limited to truck, transit mixers or transit equipment that may or may not be owned by the Contractor.

V-U. AIR POLLUTION CONTROL - Contractor shall comply with all air pollution control rules, regulations, ordinances and statutes. All containers of paint, thinner, during compound, solvent or liquid asphalt shall be labeled to indicate the contents, fully complying with the applicable material requirements.

V-V. FINAL CLEANING UP - Upon completion of the project and before making application to the General Manager for acceptable of the work, the Contractor shall clean all the streets and ground occupied by him in connection with the project, of all rubbish, debris, excess material, temporary structures and equipment, leaving the entire site of the work in a neat and presentable condition.

SPECIAL PROVISIONS (cont.)

Sub - Section 2. Specific Project Provisions

BASIN TRANSIT PROJECT: Bus Turnout and Shelter (IFB 24-01)

A. THE REQUIREMENTS: All work embraced herein shall be accomplished in accordance with the applicable portions of the "Standard Specifications for Public Works Construction," the latest edition, and all subsequent supplements herein referred to as "Standard Specifications," except as modified by these Special Provisions and the Project Plans.

In addition to the above, the Contractor shall comply with the requirements of the following:

- (a) Notice Inviting Sealed Bids
- (b) Instructions to Bidders
- (c) Proposal
- (d) Bid Bond
- (e) Information Required of Bidders
- (f) Faithful Performance Bond
- (g) Labor and Material Bond
- (h) Contract Agreement

B. DEFINITION OF TERMS: Wherever in the "Standard Specifications" terms are used, they shall be understood to mean and refer to the following:

Agency & Owner - Basin Transit

Board - Board of Directors, Basin Transit

General Manager - The General Manager of the Basin Transit

Engineer - The engineer, acting either directly or through the properly authorized agents, such agents acting within the scope of the particular duties entrusted to them.

Notice to contractors - Notice Inviting Sealed Bids

C. PROJECT PLANS: The location of the work, its general nature, extent, form and detail of the various features are listed as a part of these specifications.

D. SCOPE OF WORK: Provide necessary labor, equipment and materials to construct concrete curb and gutter, asphalt pavement, bus shelter pad, sidewalk, install Basin Transit furnished bus shelter, and associated work at SR 62 at Morongo Valley Post Office in County of San Bernardino, as specified on the drawings, and in these specifications and special provisions, and as directed by the General Manager.

E. NOTICE TO PROCEED: Upon award of this contract and signing the contract documents, the Basin Transit shall issue the Contractor a Notice to Proceed.

The work on this project shall commence within 10 calendar days of the Notice to Proceed and be completed within **30** working days. **Working days will be counted from the date of the Notice to Proceed.** Working days are defined as any day that Basin Transit offices are open for business.

The Basin Transit will not authorize any work to be done under this specifications before the contract agreement has been fully executed; and any work that is done by the contractor in advance of such time shall be considered as being done at his own risk and responsibility, and as a consequence will be subject to rejection by not having been done in the presence of an Engineer or Inspector as provided in Section 2-

10 of the Standard Specifications.

In the event that the General Manager shall be of the opinion that the work is being inadequately or improperly executed in any respect, he/she may demand that the Contractor improve or change the execution of the work in such manner as to assure proper and timely completion.

F. UTILITIES: It is anticipated that these existing utilities will not interfere with the Contractor's construction operations. However, the Contractor shall exercise due care to ensure that these utility facilities are not damaged during his operations. When in doubt, the Contractor shall contact the utility concerned before proceeding further.

G. NOTIFICATION: The Contractor shall give written and reasonable notice to occupants or owners of property adjacent to the construction site at least forty-eight (48) hours prior to the beginning of construction in their respective areas. The notification shall include the date and time of street closures, parking and traffic access information and requirements, and precautionary information regarding the work to be done. A copy of all notifications shall be submitted to the General Manager for approval.

At least four (4) working days in advance of street closures, all emergency services, public transportation services, garbage collections services, and school bus services shall be notified by the Contractor in writing of the locations, time and date of the closure. In case of schedule changes, the emergency services, etc., shall be notified by telephone at least two (2) days in advance of the street closure.

H. ACCESS TO DRIVEWAYS: The Contractor shall notify in writing residents of property adjoining the location of the work at least forty-eight (48) hours before the start of construction on that street. The Contractor is responsible for posting "temporary no-parking" signs at least forty-eight (48) hours before using the parking lane for construction purposes. In the case of work requiring excavation of the roadway which may interfere with the use by residents or businesses of their driveways, suitable provisions shall be made by the Contractor at such time as the exigencies of construction may demand a temporary blocking of said driveways. Efforts shall be made by the Contractor to minimize the duration of said blocking and to notify the residents of this need well in advance. Further, the Contractor shall provide access to each residential or commercial establishment each evening.

I. STREET CLOSURES: No closure of any street shall be allowed unless prior written permission is obtained from the General Manager. If permission to close a street is granted then the Contractor is required to notify in writing at least four (4) working days in advance, all emergency services, public transportation services, garbage collection services, and school bus services of the location, time and date of the closure.

J. CONFERENCE: The Contractor shall arrange a pre-construction meeting with the General Manager, which shall be held a minimum of five (5) working days prior to commencement of any work. The Contractor shall have his equipment available for inspection by the General Manager at the time of the pre-construction meeting.

K. PUBLIC CONVENIENCE AND SAFETY:

a) Attention is directed to Section 7-10 of the Standard Specifications and the Manual of Warning Signs, Lights and Devices for Use in Performing Work Upon Highways, published by the California Department of Transportation.

Full compensation for conforming to the requirements of Section 7-10 of the Standard Specifications, the above referenced Caltrans Manual and these Special Provisions not otherwise provided for, shall be considered as included in the prices paid for the various contract items of work and no additional compensation will be allowed therefore.

b) **WARNING AND PROTECTION DEVICES:** The Contractor will be responsible for providing, placing and maintaining approved signs, barricades, pedestals, flashers, delineators, fences, barriers and flagmen where needed, and other necessary facilities in the vicinity of the construction area and where any

dangerous conditions may be encountered as a result thereof, for the protection of the motoring public. The Contractor will not be allowed to proceed with the work until such time that a sufficient number of these protection devices have been delivered to the project site. Where parked vehicles are likely to interfere with the proposed work, the Contractor will supply and post at no less than 200-foot intervals on each side of the street "Temporary No Parking" signs twenty-four (24) hours before the start of construction and to report the time of posting to the Police Department for the purpose of establishing "Tow Away" provisions. The Contractor shall be responsible for the removal of the temporary signs upon the completion of the work.

Should the Contractor appear neglectful or negligent in furnishing warning and protection devices as outlined above, the General Manager may direct attention to the existence of a hazard and the necessity of additional or different measures which shall be furnished and installed by the Contractor at his own expense, free of any cost to the Basin Transit. Should the Contractor refuse or fail to act in a timely manner to correct a hazardous condition, the General Manager may direct Basin Transit forces to provide the necessary protective and warning devices as deemed appropriate by the General Manager.

The cost accrued by the Basin Transit in connection therewith will be deducted from the Contractor's contract payment. Any action or inaction on the part of the Basin Transit in directing attention to the inadequacy of warning and protective measures or in providing additional protective and warning devices shall not relieve the Contractor from responsibility for public safety or abrogate his obligation to furnish and pay for these devices.

The Contractor shall submit his work schedule and traffic control plans to the General Manager for approval at the pre-construction conference. This schedule shall allow residents, on the streets to be improved, ample "on street" parking within an 800-foot distance from their homes.

L. SANITARY CONVENIENCE: Necessary sanitary facilities for the use of workman on the job shall be provided and maintained in an approved manner by the Contractor, properly secluded from public observation and in compliance with health ordinances and laws, and their use shall be strictly enforced by the Contractor.

M. CONSTRUCTION YARD: It shall be the Contractor's responsibility to locate any storage sites for materials and equipment needed and such sites either located on public or private property must be approved in advance by the General Manager.

When storage sites are to be on located upon private property, the Contractor shall be required to submit to the General Manager, written approval from the record owner authorizing the use of the property by the Contractor.

N. CONSTRUCTION STAKING: Existing survey monuments shall not be disturbed unless required by the construction of the proposed improvements. The Contractor shall be required to provide any and all necessary construction survey staking required in constructing the project. Full compensation for performing any needed construction survey staking, not otherwise provided for, shall be considered as included in the prices paid for the various contract items of work and no additional compensation will be allowed therefore.

O. CONSTRUCTION METHODS:

General Requirements:

(a) Utilities--The Contractor shall contact the affected utility companies for information regarding identification, location, and depth of underground utilities.

(b) Preservation of Property--Existing improvements in areas adjoining the property whereon demolition and removal is being performed shall be protected from injury or damage resulting from operations of the Contractor and the Contractor shall be responsible for such damage. In like manner any building, structure, tree, shrub, landscaping, or other item designated for preservation on the property where

demolition and removal is being performed shall be similarly protected and preserved.

(c) Dust Control--The Contractor shall provide such dust laying equipment and methods as may be required to protect adjacent property from annoyance or damage from dust caused by his operations, and failure to control such dust shall be cause for the Engineer to stop the work until said dust is controlled, and the Contractor shall have no recourse to collect from the Basin Transit for any loss of time or expense sustained by him due to such suspension of work.

(d) Selected Materials--Existing materials excavated within the project limits that meet the specifications for trench backfill, topsoil, or other selected materials may be used to fulfill all or a portion of the requirements for such materials. No additional compensation will be allowed for excavation, stockpiling, overhaul, or placing selected materials encountered in the excavation.

(e) Surplus Materials--The Contractor shall furnish written consent from the owner of the property where it is intended to dispose of the surplus material. Surplus excavation shall become the property of the Contractor.

(f) Furnishing and Applying Water--Furnishing and applying water shall be considered as included in the bid price paid for the various contract items of work requiring such water and no additional compensation will be made therefore.

(g) Compaction Testing: – The expense of the initial testing shall be borne by Basin Transit. The expense of any re-testing required by Basin Transit, if the initial compaction does not meet the required specifications, shall be borne by the Contractor. All other material testing shall be borne by the Contractor.

(h) Construction Methods--The improvement work shall consist of providing necessary labor, equipment and materials to construct concrete curb and gutter, asphalt pavement, bus shelter pad, sidewalk, install Basin Transit furnished bus shelter, and associated work at SR 62 at Dumosa Avenue in Town of Yucca Valley and Adobe Road at Indian Trail in City of Twentynine Palms, as specified on the drawings, and in these specifications and special provisions, and as directed by the General Manager.

(i) Measurement and Payment--The Cost of all work as described above in (a) through (h) shall be included in the contract unit prices bid for the various items of work requiring such work, and no additional compensation will be allowed.

Bid Item No. 1 – Clear and Grub and Grading:

(a) General – All work shall conform to Section 300 of the Standard Specifications. The work shall consist of clearing and grubbing, import borrow material, export surplus material, excavation, embankment, removing necessary shrubs, fences, posts, and stakes, protecting existing improvements, erosion control, controlling nuisance water, sweeping, and watering.

When import is required, contractor shall provide location of borrow site, obtain Basin Transit approval of the material prior to import, and obtain Basin Transit approval of a haul route.

When export is required, contractor shall coordinate with Basin Transit for location of a disposal site for all excavated material. All excavated material shall become property of the contractor unless notified otherwise.

Contractor shall provide full access to properties adjacent to project site with the minimum amount of interruption to access as possible.

(b) Measurement and Payment – The Cost of all work described above and also including all costs of materials, labor, tools, equipment, and incidentals, and for doing all the work involved, complete in place, not otherwise paid for by other bid items, shall be included in the contract lump sum price bid for Bid Item No. 1 – Clear and Grub and Grading, and no additional compensation will be allowed.

Bid Item No. 2 – Sawcut and Remove Existing AC Pavement and AC Curb Transition:

(a) General – All work shall conform to Section 300 of the Standard Specifications. The work shall consist of removal of existing pavement to the limits shown on the project plans. The work shall also include all necessary sawcutting, disposal of materials; reinstate disturbed surrounding areas to their original conditions, and all other work necessary to complete the removal of existing AC pavement and AC curb transition, as shown on the project plans.

(b) Measurement and Payment— The cost of all work described above and also including all costs of materials, labor, tools, equipment, and incidentals, and for doing all the work involved, complete in place, shall be included in the contract unit price bid for Bid Item No. 2 – Sawcut and Remove Existing AC Pavement and AC Curb Transition, and no additional compensation will be allowed.

Bid Item No. 3 – 6” Concrete Curb and Curb Transition:

(a) General -- All work shall conform to Caltrans Standard Specifications, and the Caltrans Standard Plans. The work shall consist of preparation of new subgrade by scarifying and re-compacting, set and remove forms, placing concrete, installing joints, and all other work necessary to complete the construction of concrete curb and curb transition.

(b) Measurement and Payment -- The cost of all work described above and also including all costs of materials, labor, tools, equipment, and incidentals, and for doing all the work involved, complete in place, shall be included in the contract unit price bid for Bid Item No. 3 – 6” Concrete Curb and Curb Transition, and no additional compensation will be allowed.

Bid Item No. 4 – 4” Thick Concrete Sidewalk:

(a) General – All work shall conform to Sections 300, 301, and 303 of the Standard Specifications, and San Bernardino County Standard Drawings. The work shall consist of preparation of new subgrade by scarifying and re-compacting, set and remove forms, placing concrete, installing joints, and all other work necessary to complete the construction of concrete sidewalk.

(b) Measurement and Payment – The cost of all work described above and also including all costs of materials, labor, tools, equipment, and incidentals, and for doing all the work involved, complete in place, shall be included in the contract unit price bid for Bid Item No. 4 – 4” Thick Concrete Sidewalk, and no additional compensation will be allowed.

Bid Item No. 5 – 6” Thick Concrete Bus Shelter Pad:

(a) General -- All work shall conform to Sections 300, 301, and 303 of the Standard Specifications. The work shall consist of fine grading, preparation of new subgrade by scarifying and re-compacting, set and remove forms, placing steel reinforcement, placing concrete, installing joints, and all other work necessary to complete the construction of concrete bus shelter pad.

(b) Measurement and Payment -- The cost of all work described above and also including all costs of materials, labor, tools, equipment, and incidentals, and for doing all the work involved, complete in place, shall be included in the contract unit price bid for Bid Item No. 5 – 6” Thick Concrete Bus Shelter Pad, and no additional compensation will be allowed.

Bid Item No. 6 – 6” Thick Concrete Block Slough Wall:

(a) General -- All work shall conform to Sections 300, 301, and 303 of the Standard Specifications, and

APWA Standard Drawings. The work shall consist of excavation, preparation of new subgrade by scarifying and re-compacting, set and remove forms, construction of concrete footing, construction of masonry wall, installing joints, curing, finishing, and all other work necessary to complete the slough wall.

(b) Concrete masonry blocks shall be split faced, tan in color (tentative only, final color to be determined), and shall match nearby existing wall. Provide a matching coping piece on top of wall.

(c) Measurement and Payment -- The cost of all work described above and also including all costs of materials, labor, tools, equipment, and incidentals, and for doing all the work involved, complete in place, shall be included in the contract unit price bid for Bid Item No. 6 – 6” Thick Concrete Block Slough Wall, and no additional compensation will be allowed.

Bid Item No. 7 – 0.85’ Thick Concrete Bus Turnout On 0.5’ Thick Lean Concrete Base:

(a) General -- All work shall conform to Caltrans Standard Specifications. The work shall consist of preparation of new subgrade by scarifying and re-compacting, set and remove forms, placing lean concrete base, placing concrete pavement, installing joints and dowel bars, and all other work necessary to complete the construction of concrete bus turnout on lean concrete base.

(b) Measurement and Payment -- The cost of all work described above and also including all costs of materials, labor, tools, equipment, and incidentals, and for doing all the work involved, complete in place, shall be included in the contract unit price bid for Bid Item No. 7 – 0.85’ Thick Concrete Bus Turnout On 0.5’ Thick Lean Concrete Base, and no additional compensation will be allowed.

Bid Item No. 8 – AC Backfill and AC Curb Transition:

(a) General – All Work shall conform to Section 39-2 of the Caltrans Standard Specifications. The work shall consist of preparation of new subgrade by scarifying and re-compacting, placing asphalt concrete, compaction, removal of loose and broken asphalt concrete pavement and foreign materials, and all other work necessary to complete the asphalt concrete backfill.

(b) Material – Asphalt concrete shall be Type A HMA, C2-PG 64-16 conforming to Section 39-2 of the Caltrans Standard Specifications. Aggregates shall be ½” maximum dense medium grade.

(c) Tack Coat – A tack coat shall be furnished by the contractor and applied to all vertical and horizontal joints, between pavement layers, on concrete surfaces, and on existing pavement to be resurfaced, prior to placing the asphalt concrete, in accordance with Section 39-2 of the Caltrans Standard Specifications.

(d) Measurement and Payment – The Cost of all work described above and also including all costs of materials, labor, tools, equipment, and incidentals, and for doing all the work involved, complete in place, shall be included in the contract unit price bid for Bid Item No. 8 – AC Backfill and AC Curb Transition, and no additional compensation will be allowed. No separate measurement and payment will be made for asphalt tack coat

Bid Item No. 9 – Transport, Assemble, and Install Basin Transit Furnished Bus Shelter, Bench, and Trash Receptacle:

(a) General – All work shall conform to manufacturer’s recommendations and Basin Transit requirements. The work shall consist of loading, deliver, and unloading bus shelter, bench, and trash receptacle from Basin Transit Offices at Joshua Tree to job sites, then assemble and install bus shelter, bench, trash receptacle, including anchor to concrete pad, and all other work necessary to complete the installation of bus shelter, bench, and trash receptacle.

(b) Measurement and Payment – The cost of all work described above and also including all costs of

materials, labor, tools, equipment, and incidentals, and for doing all the work involved, complete in place, shall be included in the contract unit price bid for Bid Item No. 9 – Transport, Assemble, and Install Basin Transit Furnished Bus Shelter, Bench, and Trash Receptacle, and no additional compensation will be allowed.

Bid Item No. 10 – Install Basin Transit Furnished Bus Stop Sign and Post:

(a) General – All work shall conform to Caltrans Standard Specifications and Basin Transit requirements. The work shall consist of installation of Basin Transit furnished bus stop sign and post, and shall include all necessary sawcutting, excavation, footing, backfill, and compaction, as shown on the project plans.

(b) Measurement and Payment – The cost of all work described above and also including all costs of materials, labor, tools, equipment, and incidentals, and for doing all the work involved, complete in place, shall be included in the contract unit price bid for Bid Item No. 10 – Install Basin Transit Furnished Bus Stop Sign and Post, and no additional compensation will be allowed.

Bid Item No. 11 – Relocate Existing Speed Limit Sign and Posts:

(a) General – All work shall conform to Caltrans Standard Plans and Specifications. The work shall consist of removal of existing traffic sign and post from current location and installation at new location, and shall include excavation, remove and reconstruct concrete footings, backfill, and compaction, as shown on the project plans.

(b) Measurement and Payment – The cost of all work described above and also including all costs of materials, labor, tools, equipment, and incidentals, and for doing all the work involved, complete in place, shall be included in the contract unit price bid for Bid Item No. 11 – Relocate Existing Speed Limit Sign and Posts, and no additional compensation will be allowed.

Bid Item No. 12 – Paint New Curb with Red Paint Per Caltrans Standard Specifications Section 84-2:

(a) General – All work shall conform to Caltrans Standard Specifications. The work shall consist of furnish and install paint, as shown on the project plans.

(b) Measurement and Payment – The cost of all work described above and also including all costs of materials, labor, tools, equipment, and incidentals, and for doing all the work involved, complete in place, shall be included in the contract unit price bid for Bid Item No. 12 – Paint New Curb With Red Paint Per Caltrans Standard Specifications Section 84-2, and no additional compensation will be allowed.

Bid Item No. 13 – Channelizing Line Per Caltrans Standard Specifications Section 84-2:

(a) General – All work shall conform to Caltrans Standard Specifications and Caltrans Standard Plans. The work shall consist of furnish and install paint, as shown on the project plans.

(b) Measurement and Payment – The cost of all work described above and also including all costs of materials, labor, tools, equipment, and incidentals, and for doing all the work involved, complete in place, shall be included in the contract unit price bid for Bid Item No. 13 – Channelizing Line Per Caltrans Standard Specifications Section 84-2, and no additional compensation will be allowed.

Bid Item No. 14 – Construction Staking:

(a) General – All work shall conform to Caltrans Standard Specifications and the project plans. The

work shall consist of providing construction surveying and staking, and all other work necessary to perform the staking. Cut sheets and field notes shall be submitted to the Engineer.

(b) Measurement and Payment – The cost of all work described above and also including all costs of materials, labor, tools, equipment, and incidentals, and for doing all the work involved, complete in place, shall be included in the contract lump sum price bid for Bid Item No. 14 – Construction Staking, and no additional compensation will be allowed.

Bid Item No. 15 – Coordination with Caltrans, Obtain Caltrans Double Permit, Comply with Permit Provisions, and Traffic Control:

(a) General – All work shall conform to the Caltrans Traffic Control Plan and Caltrans requirements. The work shall consist of coordination with Caltrans for a pre-construction meeting, inspection, and all other activities throughout the construction period; obtain and pay for a Caltrans double permit at Caltrans District 8 Permit Division (permit fee will be reimbursed by Basin Transit); comply with all permit provisions; and furnish, install, maintain, relocate, and remove traffic control devices, including flashing arrow and flashing beacon, throughout the construction period.

(b) Measurement and Payment – The cost of all work described above and also including all costs of materials, labor, tools, equipment, and incidentals, and for doing all the work involved, complete in place, shall be included in the contract lump sum price bid for Bid Item No. 15 – Coordination with Caltrans, Obtain Caltrans Double Permit, Comply With Permit Provisions, and Traffic Control, and no additional compensation will be allowed.

PROPOSAL

TO THE BOARD OF DIRECTORS OF THE BASIN TRANSIT

The undersigned, as bidder, declares that: (1) this proposal is made without collusion with any other person, firm or corporation, and that the only persons or parties interested as principals are those named herein; (2) bidder has carefully examined the project plans, specifications, instructions to bidders, proposal, notice to contractors and all other information furnished therefore and the site of the proposed work; (3) bidder has investigated and is satisfied as to the conditions to be encountered, the character, quality and quantities of work to be performed and materials to be furnished. Furthermore, bidder agrees that submission of this proposal shall be conclusive evidence that such examination and investigation have been made and agrees, in the event this contract be awarded to bidder, to enter into a contract with the Board of Directors of the Basin Transit, to perform said proposed work in accordance with the plans, if any, and the terms of the specifications, in the time and manner therein prescribed, and to furnish or provide all materials, labor, tools, equipment, apparatus and other means necessary so to do, except such thereof as may otherwise be furnished or provided under the terms of said specifications, for the following stated unit prices or lump sum price as submitted on the Schedule attached hereto.

The bidder shall submit as part of this proposal a completed copy of the Contractor's Industrial Safety Record.

Accompanying this proposal is _____ (Insert "\$_____ cash", "Cashier's Check", "certified check", or "Bid Bond", as the case may be) in the amount equal to at least ten percent (10%) of the total aggregate bid price hereof based on the quantities shown and the unit prices quoted.

The undersigned further agrees that should he be awarded the contract on the basis hereof and thereafter, defaults in executing the required contract, with necessary bonds and documents, within fifteen (15) calendar days, after having received notice that the contract has been awarded and is ready for signature, the proceeds of the security accompanying his bid shall become the property of the Basin Transit and this proposal and the acceptance thereof may be considered null and void.

The undersigned is licensed in accordance with an act providing for the registration of contractors, California

Contractor's License No. _____, Class _____.

Signature(s) of bidder _____

If an individual, so state. If a firm or co-partnership, state the firm name and give the names of all individual co-partners composing the firm. If a corporation, state legal name of corporation, also names of president, secretary, treasurer, and manager thereof. Two notarized officer's signatures and the corporate seal are required for corporations. One signature must be by either the President or Vice-President and the second signature must be by either the secretary or assistant secretary.

By: _____
Title: _____

"corporate seal"

By: _____
Title: _____

By: _____
Title: _____

Basin Transit – Bus Turnout and Shelter (IFB 24-01)

By: _____

Legal Business Name:

Address _____

Telephone _____

Proposals which do not show the number and date of the Bidder's License under the provisions of Chapter 9 of Division 3 of the Business & Professional Code may be rejected.

To be submitted with each bid:

Project Identification No. _____ to contract for _____

Bid Date _____

This information must include all construction work undertaken in the State of California by the bidder and partnership joint venture or corporation that any principal of the bidder participated in as a principal or owner for the last five calendar years and the current calendar year prior to the date of bid submittal. Separate information shall be submitted for each particular partnership, joint venture, corporate or individual bidder. The bidder may attach any additional information or explanation of data which he would like to be taken into consideration in evaluating the safety record. An explanation must be attached of the circumstances surrounding any and all fatalities.

PROPOSAL

PAY ITEMS AND BID PRICE SCHEDULE

To the Board of Directors of the Basin Transit:

In compliance with the Notice Inviting Sealed Bids, the undersigned hereby agrees to enter into a contract to furnish all labor, materials, equipment and supplies for **Bus Stop and Shelter (IFB 24-01)** in accordance with the specifications and plans in the Contract Documents which are on file in the office of the General Manager of the Basin Transit to the satisfaction and under the direction of the General Manager at the following prices:

Item	Description	Qty.	Unit	Unit Price	Extended Amount
1	Clear and Grub and Grading (See page C-14 for description)	1	LS	\$ _____	\$ _____
2	Sawcut and Remove Existing AC Pavement and AC Curb Transition (See page C-15 for description)	350	SF	\$ _____	\$ _____
3	6" Concrete Curb and Curb Transition (See page C-15 for description)	145	LF	\$ _____	\$ _____
4	4" Thick Concrete Sidewalk (See page C-15 for description)	560	SF	\$ _____	\$ _____
5	6" Concrete Bus Shelter Pad (See page C-15 for description)	80	SF	\$ _____	\$ _____
6	6" Thick Concrete Block Slough Wall (See page C-15 for description)	25	LF	\$ _____	\$ _____
7	0.85' Thick Concrete Bus Turnout On 0.5' Thick Lean Concrete Base (See page C-16 for description)	760	SF	\$ _____	\$ _____
8	AC Backfill and AC Curb Transition (See page C-16 for description)	140	SF	\$ _____	\$ _____
9	Transport, Assemble and Install Basin Transit Furnished Bus Shelter, Bench, and Trash Receptacle (See page C-16 for description)	1	EA	\$ _____	\$ _____
10	Install Basin Transit Furnished Bus Stop Sign and Post (See page C-17 for description)	1	EA	\$ _____	\$ _____
11	Relocate Existing Speed Limit Sign (See page C-17 for description)	1	EA	\$ _____	\$ _____

Basin Transit – Bus Turnout and Shelter (IFB 24-01)

Item	Description	Qty.	Unit	Unit Price	Extended Amount
12	Paint New Curb With Red Paint Per Caltrans Standard Specifications Section 84-2 (See page C-17 for description)	140	LF	\$ _____	\$ _____
13	Channelizing Line Per Caltrans Standard Specifications Section 84-2 (See page C-17 for description)	60	LF	\$ _____	\$ _____
14	Construction Staking (See page C-17 for description)	1	LS	\$ _____	\$ _____
15	Coordination with Caltrans, Obtain Caltrans Double Permit, Comply With Permit Provisions, and Traffic Control (See page C-18 for description)	1	LS	\$ _____	\$ _____

TOTAL BID FOR ITEMS 1 TO 15:

\$ _____
(Figure)

TOTAL BID FOR ITEMS 1 TO 15:

(Words)

Bidder acknowledges receipt of the following Addendum:

Addendum No. _____ Date: _____

Addendum No. _____ Date: _____

Attached to this Proposal is cash, a cashiers check, or certified check in favor of the Basin Transit, in an amount equal to at least ten percent (10%) of the total bid, or a bid bond for said amount in the form furnished by the Basin Transit, with the understanding that said security shall be held by the Basin Transit until the agreement for doing the work has been entered into, that said security shall be forfeited to the Basin Transit as liquidated damages should the undersigned fail to enter into a contract and furnish the required bonds and insurance within the time specified in the Contract Documents, if awarded the contract, and the undersigned agrees that in the event of such failure, the actual amount of damages to the Basin Transit would be impractical and extremely difficult to determine.

Dated: _____

FIRM NAME _____

If a partnership, names of partners. If a corporation, names of President and Vice President, and the Secretary

Basin Transit – Bus Turnout and Shelter (IFB 24-01)

or Assistant Secretary.

SIGNATURE _____

Title _____

SIGNATURE _____

Title _____

SIGNATURE _____

Title _____

NAME & ADDRESS:

TELEPHONE _____

CONTRACTOR'S LICENSE NO. _____

Please indicate whether proprietorship, corporation, or partnership and any use of fictitious business name:

Corporation ____ Partnership ____ Proprietorship ____

Fictitious Name _____

CONTRACTOR'S INDUSTRIAL SAFETY RECORD

Record Last Five (5) Full Years

Year	2020	2021	2022	2023	2024	Total
No. of contracts						
Total amount of contracts (Thousands of dollars)						
No. of lost work days*						
No. of fatalities*						
No. of lost workday cases involving permanent transfer to another job or termination of employee*						

*The information required for these items is the same as required for columns 3 to 6, Code 10, Occupational Injuries, Summary--Occupational Injuries and Illnesses, OSHA No. 102.

The above information was compiled from the records that are available to me at this time and I declare under penalty of perjury that the information is true and accurate within the limitations of those records.

Name of Bidder (print)

Signature

Address

State Contractor's Lic. No. & Classification

City

Zip Code

Telephone

(THE BIDDER'S EXECUTION ON THE SIGNATURE PORTION OF THIS PROPOSAL SHALL ALSO CONSTITUTE AN ENDORSEMENT AND EXECUTION OF THOSE CERTIFICATIONS WHICH ARE A PART OF THIS PROPOSAL)

EQUAL EMPLOYMENT OPPORTUNITY CERTIFICATION

The bidder _____, proposed subcontractor _____, hereby certifies that he has _____, has not _____, participated in a previous contract or subcontract subject to the equal opportunity clause, as required by Executive Orders 10925, 11114, or 11246, and that, where required, he has _____, has not _____, filed with the Joint Reporting Committee, the Director of the Office of Federal Contract Compliance, a Federal Government contracting or administering agency, or the former President's Committee on Equal Employment Opportunity, all reports due under the applicable filing requirements.

Note: The above certification is required by the Equal Employment Opportunity Regulations of the Secretary of Labor (41 CFR 60-1.7(b)(1)), and must be submitted by bidders and proposed subcontractors only in connection with contracts and subcontracts which are subject to the equal opportunity clause. Contracts and subcontracts which are exempt from the equal opportunity clause are set forth in 41 CFR 60-1.5. (Generally only contracts or subcontracts or \$10,000.00 or under are exempt.)

Currently, Standard Form 100 (EEO-1) is the only report required by the Executive Orders or their implementing regulations.

Proposed prime contractors and subcontractors who have participated in a previous contract or subcontract subject to the Executive Orders and have not filed the required reports should note that 41 CFR 60-1.7(b)(1) prevents the award of contracts and subcontracts unless such contractor submits a report covering the delinquent period or such other period specified by the Federal Highway Administration or by the Director, Office of Federal Contract Compliance, U.S. Department of Labor.

This certification for the prime contractor must be submitted at bid time with the bid. Certification for subcontractors, if not submitted at bid time, can be submitted within seven days after bid opening.

LIST OF SUBCONTRACTORS

In compliance with the provisions of the Public Contract Code, Section 4104, the undersigned bidder herewith sets forth the name and location of the place of business of each subcontractor who will perform work or labor or render service to the general Contractor in or about the construction of the work or improvement in an amount in excess of one-half of one percent (1/2 of 1%) of the Contractor's total bid, or in the case of bids for the construction of streets or highways, including bridges, in excess of 1/2 of 1% of the prime contractor's total bid or Ten Thousand Dollars (\$10,000.00) whichever is greater, and the portion of the work which will be done by each subcontractor is as follows:

SUBCONTRACTOR'S NAME	PLACE OF BUSINESS	DESCRIPTION OF WORK
_____	_____	_____
_____	_____	_____
_____	_____	_____
_____	_____	_____
_____	_____	_____
_____	_____	_____
_____	_____	_____
_____	_____	_____
_____	_____	_____
_____	_____	_____
_____	_____	_____
_____	_____	_____
_____	_____	_____
_____	_____	_____
_____	_____	_____
_____	_____	_____
_____	_____	_____
_____	_____	_____
_____	_____	_____

NONCOLLUSION AFFIDAVIT

(Title 23 United States Code Section 112 and
Contract Code Section 7106)

To the Basin Transit

In accordance with Title 23 United States Code Section 112 and Public Contract Code 7106 the bidder declares that the bid is not made in the interest of or on behalf of, any undisclosed person, partnership, company, association, organization, or corporation; that the bid is genuine and not collusive or sham; that the bidder has not directly or indirectly induced or solicited any other bidder to put in a false or sham bid, and has not directly or indirectly colluded, conspired, connived, or agreed with any bidder or anyone else to put in a sham bid, or that anyone shall refrain from bidding; that the bidder has not in any manner, directly or indirectly, sought by agreement, communication, or conference with anyone to fix the bid price of the bidder or any other bidder, or to fix any overhead, profit, or cost element of the bid price, or of that of any other bidder, or to secure, any advantage against the public body awarding the contract of anyone interested in the proposed contract; that all statements contained in the bid are true; and, further, that the bidder has not, directly or indirectly, submitted his or her bid price or any breakdown thereof, or the contents thereof, or divulged information or data relative thereto, or paid, and will not pay, any fee to any corporation, partnership, company association, organization, bid depository, or to any member or agent thereof to effectuate a collusive or sham bid.

Note: The above Non-collusion Affidavit is part of the Proposal. Signing this Proposal on the signature portion thereof shall also constitute signature of the Non-collusion Affidavit.

Bidders are cautioned that making a false certification may subject the certifier to criminal prosecution.

DEBARMENT AND SUSPENSION CERTIFICATION

TITLE 49, CODE OF FEDERAL REGULATIONS, PART 29

The bidder, under penalty of perjury, certifies that, except as noted below, he/she or any other person associated therewith in the capacity of owner, partner, director, officer, manager:

- is not currently under suspension, debarment, voluntary exclusion, or determination of ineligibility by any federal agency;
- has not currently under suspension, debarment, voluntarily excluded or determined ineligible by any federal agency within the past three (3) years;
- does not have a proposed debarment pending; and
- has not been indicted, convicted, or had a civil judgment rendered against it by a court of competent jurisdiction in any matter involving fraud or official misconduct within the past three (3) years.

If there are any exceptions to this certification, insert the exceptions in the following space.

Exceptions will not necessarily result in denial of award, but will be considered in determining bidder responsibility. For any exception noted above, indicate below to whom it applies, initiating agency, and dates of action.

Notes: Providing false information may result in criminal prosecution or administrative sanctions.

The above certification is part of the Proposal. Signing this Proposal on the signature portion thereof shall also constitute signature of this Certification.

BIDDER'S BOND TO ACCOMPANY PROPOSAL

BASIN TRANSIT STATE OF CALIFORNIA

KNOWN ALL PERSONS BY THESE PRESENTS:

That we, _____ as Principal, and _____ as Surety, are held and firmly bound unto the Basin Transit in the sum of _____ (\$_____) dollars, to be paid to the said Basin Transit or its certain attorneys, its successors and assigns; for the payment of which sum, well and truly made, we bind ourselves, our heirs, executors and administrators, successors or assigns, jointly and severally, firmly by these presents.

THE CONDITION OF THIS OBLIGATION IS SUCH

That if the certain proposal of the above bounded _____ to _____ dated _____, 20____, is accepted by the Basin Transit, and if the above bounded _____ his heirs, executors, administrators, successors and assigns, shall duly enter into and execute a contract for such construction, and shall execute and deliver the two bonds described within fifteen (15) calendar days, from the date of the mailing of a notice to the above bounden _____ by and from the said Basin Transit that said contract is ready for execution, then this obligation shall become null and void; otherwise it shall be and remain in full force and virtue.

IN WITNESS WHEREOF, we hereunto set our hands and seals this _____ day of _____, 20____.

Principal

By _____
Title:

"corporate seal"

By _____
Title:

Surety

"corporate seal"

By _____
Attorney-in-Fact

PLEASE ATTACH NOTARY ACKNOWLEDGEMENT (for Bonding Company's Signature Only)

INFORMATION REQUIRED OF BIDDERS

The bidder is required to supply the following information. Additional sheets may be attached if necessary.

(1) Name: _____

(2) Address: _____

(3) Telephone: _____

(4) Type of firm - Individual, Partnership, or Corporation: _____

(5) Corporation organized under the laws of the State of: _____

(6) Contractor's license no. and class: _____

(7) List the names and addresses of all members of the firm or names and titles of all officers of the corporation:

(8) Number of years experience as a contractor in construction work: _____

(9) List at least three projects completed as of recent date:

<u>Contract Amount</u>	<u>Class of Work</u>	<u>Date Completed</u>	<u>Name & Address of Owner</u>
------------------------	----------------------	-----------------------	------------------------------------

_____	_____	_____	_____
_____	_____	_____	_____
_____	_____	_____	_____
_____	_____	_____	_____
_____	_____	_____	_____

(10) List the name of the person who inspected the site of the proposed work for your firm:

(11) NOTE: Upon request of the Basin Transit, the bidder shall furnish evidence showing a notarized financial statement, financial data, construction experience, or other information.

PERFORMANCE BOND

KNOW ALL MEN BY THESE PRESENTS: THAT

WHEREAS, the Basin Transit, in the County of San Bernardino, State of California, by Council action of _____, has awarded to _____ hereinafter designated as the "Principal," a contract for construction of the _____ together with appurtenances thereto, and WHEREAS, said Principal is required under the terms of said Contract to furnish a bond for the faithful performance of said Contract.

NOW, THEREFORE, we _____ as Principal, and _____ as Surety, are held and firmly bound unto the Basin Transit, hereinafter called the "Contracting Basin Transit" in the penal sum of one hundred percent (100%) of the amount of _____ Dollars (\$_____), lawful money of the United States of America, for payment of which sum well and truly to be made, we bind ourselves, our heirs, executors, administrators and successors, jointly and severally, firmly by these presents.

THE CONDITION OF THE OBLIGATION IS SUCH that, if the hereby bounded Principal, his or its heirs, executors, administrators, successors or assigns, shall in all things stand to and abide by and well and truly keep and perform all the undertakings, terms, covenants, conditions and agreements in said Contract and any alteration thereof, made as therein provided all within the time and in the manner therein designated and in all respects according to their true intent and meaning, then this obligation shall become null and void, otherwise it shall be and remain in full force and virtue.

FURTHER, said Surety, for value received, hereby stipulates and agrees that no change, extension of time, alteration or modification of the Contract Documents or of the work to be performed thereunder shall in any way affect its obligation on this bond, and it does hereby waive notice of any such change, extension of time, alteration or modification of the Contract Documents or of work to be performed thereunder.

IN WITNESS WHEREOF, three (3) identical counterparts of this instrument, each of which shall for all purposes be deemed an original thereof, have been duly executed by the Principal and Surety herein named on the ____ day of _____, 20___. The name and corporate seal of each corporate party being hereto affixed and these presents fully signed by its undersigned representative pursuant to authority of its governing body.

Principal
By _____
Title:

"corporate seal"

By _____
Title:

"corporate seal"

Surety
By _____
Attorney-in-Fact

PLEASE ATTACH NOTARY ACKNOWLEDGEMENT

PAYMENT BOND

(BOND FOR LABOR AND MATERIAL)

KNOW ALL MEN BY THESE PRESENTS: THAT

WHEREAS, the Basin Transit, in the County of San Bernardino, State of California, by Board action of _____, has awarded to _____ hereinafter designated as the "Principal," a contract for construction of the _____ together with appurtenances thereto, and

WHEREAS, said Principal is required to furnish a bond in connection with said contract providing that if said Principal, or any of his or its subcontractors shall fail to pay for any materials, provisions, provender, fuel, or other supplies or equipment used in, upon, or about the performance of the work contracted to be done, or for any work or labor done thereon of any kind, the Surety of this bond will pay the same to the extent hereinafter set forth;

NOW, THEREFORE, we _____ as Principal, and _____ as Surety, are held and firmly bound unto the Basin Transit, hereinafter called the contracting Authority, in the penal sum of one hundred percent (100%) of the amount of _____ Dollars (\$ _____), lawful money of the United States of America, for the payment of which sum well and truly to be made, we bind ourselves, our heirs, executors, administrators, successors, jointly and severally, firmly by these presents.

THE CONDITION OF THIS OBLIGATION IS SUCH THAT if said Principal, his or its heirs, executors, administrators, successors, or assigns, shall fail to pay for any materials, provisions, provender, rented or hired teams, implements, or machinery, or other supplies or equipment of any kind used in, upon, for or about the performance of the work contracted to be done, including, but not limited to, that part of water, gas, power, light, heat, oil, gasoline, or telephone service directly applicable to the contract, or for any work or labor thereon of any kind, or for any amounts due under the California Unemployment Insurance Code with respect to such work or labor, or for any amounts required to be deducted, withheld, and paid over to the Employment Development Department from the wages of the employees of said Principal and subcontractors pursuant to Section 13020 of the California Unemployment Insurance Code with respect to such work and labor, and provided that any person, so furnishing said supplies or equipment therefore shall have complied with the provisions of Chapter 7 of Title 15 of Part 4 of Division 3 of the California Civil Code, as amended, or any successor thereto, then said Surety shall pay the same in or to an amount not exceeding the amount hereinabove set forth and also shall pay in case suit is brought upon this bond, such reasonable attorney's fees as shall be fixed by the court.

The bond shall inure to the benefit of any and all persons, companies, and corporations named in California Civil Code Section 3181, as amended, or any successor thereto, so as to give a right of action to them or their assigns in any suit brought upon this bond.

FURTHER, the Surety, for value received, hereby stipulates and agrees that no change, extension of time, alteration, or modifications of the Contract Documents or of the work to be performed thereunder shall in any way affect its obligations of this bond and it does hereby waive notice of such change, extension of time, alteration, or modification of the Contract Documents or of work to be performed thereunder.

Notices, papers and other documents required by Chapter 2 of Title 14 of Part 2 of Code of Civil Procedure, or by any other law, regulation, or requirement of the Contract may be served upon Principal at this address:

and upon Surety at this address:

IN WITNESS WHEREOF, three (3) identical counterparts of this instrument, each of which shall for all purposes be deemed an original thereof, have been duly executed by the Principal and Surety herein named, under penalty of perjury, on the _____ day of _____, 20__, the name and corporate seal of each corporate party being hereto affixed and these presents duly signed by its undersigned representative pursuant to authority of its governing body.

Principal

By _____
Title:

"corporate seal"

By _____
Title:

Surety

"corporate seal"

By _____
Attorney-in-Fact

PLEASE ATTACH NOTARY ACKNOWLEDGEMENT

WORKER'S COMPENSATION CERTIFICATE OF INSURANCE

WHEREAS, the Basin Transit has required certain insurance to be provided by

NOW THEREFORE, the undersigned insurance company does hereby certify that it has issued the policy or policies described below to the following named insureds and that the same are in force at this time.

1. This certificate is issued to: Basin Transit, 62405 Verbena Road, Joshua Tree, California 92252.
2. The insureds under such policy or policies are: _____
3. Worker's Compensation Policy or Policies in a form approved by the Insurance Commissioner of California covering all operations of the named insureds, as follows:

POLICY NUMBER	EFFECTIVE DATE	EXPIRATION DATE
_____	_____	_____
_____	_____	_____
_____	_____	_____

4. Said policy or policies shall not be canceled, nor shall there be any reduction in coverage or limits of liability, unless and until thirty (30) days' written notice thereof has been served upon the General Manager of the Basin Transit.

By: _____
Authorized Representative

INSURANCE REQUIREMENTS FOR THE BASIN TRANSIT

PUBLIC WORKS CONTRACT

The Contractor shall at all times during the terms of the contract carry, maintain, and keep in full force and effect, a policy or policies of comprehensive Public Liability Insurance with an insurance company acceptable to, and approved by, the General Manager and Attorney, with minimum limits of One Million Dollars (\$1,000,000.00), combined single limit coverage against any injury, death, loss or damage as a result of wrongful or negligent acts or omissions by the Contractor, together with an endorsement in substantially the form set forth below.

ENDORSEMENT

It is hereby understood and agreed that the Basin Transit, its Board of Directors and each member thereof, and every officer, agent (including but not limited to employees of Charles Abbott Associates, Inc. and all other Basin Transit consultants) and employees of the Basin Transit shall be named as jointly and severally insured as respects any and all claims arising out of the following project:

BUS TURNOUT AND SHELTER (IFB 24-01)

It is further agreed that the following indemnity agreement between the Basin Transit and the named insured is covered under the policy: Contractor agrees to indemnify, hold harmless and defend (with attorneys of the Basin Transit's choice) the Basin Transit, its Board of Directors and each member thereof and every officer, agent (including but not limited by this reference to employees of Charles Abbott Associates, Inc.) and employee of the Basin Transit from any and all liability or financial loss resulting from any suits, claims, losses or actions brought against and from all cost and expenses of litigation brought against the Basin Transit, its Board of Directors and each member thereof and any officer, agent (including but not limited by this reference to employees of Charles Abbott Associates, Inc.) or employee of the Basin Transit which results directly or indirectly from the wrongful or negligent actions of the Contractor or the Contractor's officers, employees, agents or others employed by the Contractor while engaged by the Contractor in the performance of this agreement.

It is further agreed that the inclusion of more than one insured shall not operate to increase the limit of the company's liability and that insurers waive any right of contribution with insurance which may be available to the Basin Transit, the Contractor's insurance being primary and not contributing with any other insurance available to the Basin Transit and other above identified insureds.

In the event of cancellation or material change in the above coverage the company will give thirty (30) days written notice of cancellation or material change to the certificate holder (the Basin Transit).

**INSTRUCTIONS FOR EXECUTION OF INSTRUMENTS
FOR THE BASIN TRANSIT**

THIS IS INSTRUCTION ONLY - IT IS NOT TO BE SIGNED OR USED IN CONJUNCTION WITH THE AGREEMENT OR ANY OTHER FORMS THAT MUST BE TURNED INTO THE BASIN TRANSIT - IT IS SIMPLY A FORMAT TO USE WHEN FILLING OUT DOCUMENTS.

1. By an Individual. The individual must sign the instrument, and if he is doing business under a fictitious name, the fictitious name must be set forth. The signature must be acknowledged before a Notary Public, using the proper form of acknowledgment.

2. By a Partnership. The name of the partnership must be set forth followed by the signatures of less than all of the partners will be acceptable only if submitted with evidence of authority to act on behalf of the partnership. The signatures must be acknowledged before a Notary Public, using the proper form of acknowledgment.

3. By a Corporation. The name of the corporation must be set forth, followed by the signatures of the President or Vice President and Secretary or Assistant Secretary. The signatures must be acknowledged before a Notary Public, using in substance the following form of acknowledgment.

4. By a Surety. The name of the surety must be set forth, followed by an authorized signature. The signatures must be acknowledged before a Notary Public, using the proper form of acknowledgment.

STATE OF _____)
) SS.
COUNTY OF _____)

On _____, 20____, before me, the undersigned, appeared _____, known to me to be the President or Vice President and _____, known to be to be the (Secretary) (Assistant Secretary) of the corporation that executed the within instrument, and acknowledged to me that such corporation executed the within instrument pursuant to its by-laws or a resolution of its Board of Directors.

WITNESS my signature and seal.

Notary Public

(Seal)

CONTRACT

BASIN TRANSIT

THIS AGREEMENT is made and entered into this _____, by and between the Basin Transit, hereinafter referred to as "Basin Transit," and _____ hereinafter referred to as "Contractor."

WITNESSETH:

WHEREAS, Contractor and Contractor's Surety are providing the bonds attached hereto as Exhibit B and incorporated by this reference, and

WHEREAS, Basin Transit desires to contract with Contractor to perform the services detailed in this contract, including the Proposal, and

WHEREAS, Contractor has represented that it is fully qualified to assume and discharge such responsibility;

NOW, THEREFORE, the parties hereto do agree as follows:

1. Scope of Services - Basin Transit hereby employs Contractor to perform the work and provide the services and materials as described in the Notice to Contractors, Instructions to Bidders, Special Provisions and the Proposal, attached hereto as Exhibit A and incorporated herein by this reference, including miscellaneous appurtenant work. Such work shall be performed in a good and workmanlike manner, under the terms as stated herein and in the Notice to Contractors, Instructions to Bidders, Special Provisions and the Proposal, and in accordance with the latest edition of the Joint Cooperative Committee, Southern California Chapters of the American Public Works Association and the Associated General Contractors of America, document entitled "Standard Specifications." In the event of any conflict between the terms of this agreement and any of the above-referenced documents, the terms of this agreement shall be controlling.
2. Compensation - In consideration of the services rendered hereunder, Contractor shall be paid according to the prices as submitted on the Pay Items and Bid Price Schedule of the Proposal, attached hereto as part of Exhibit A and in accordance with the Special Provisions.
3. Hold Harmless; Insurance - It is specifically understood and agreed by all parties hereto that Contractor is, for the purposes of this Agreement, an independent contractor and not an employee of the Basin Transit. Accordingly, Contractor shall not be deemed the Basin Transit's employee for any purpose whatsoever. Contractor shall not incur or have the power to incur any debt, obligation or liability whatever for or against Basin Transit and shall hold harmless, indemnify and defend with the attorneys of the Basin Transit's choice, the Basin Transit its officers, employees, agents and representatives, from and against any and all obligations, claims, liens, or causes of actions, arising out of or related to Contractor's services hereunder. Contractor shall file and maintain with Basin Transit at all times during the term of this Agreement, a copy or certificate of general liability insurance with an insurance company acceptable to, and approved by, the General Manager and Attorney of the Basin Transit, with minimum limits of One Million Dollars (\$1,000,000.00) combined single limit coverage against any injury, death, loss or damage as a result of wrongful or negligent acts or omissions by the Contractor. Such insurance shall not be canceled without thirty (30) days' prior written notice to Basin Transit, shall name the Basin Transit and its officers and employees as additional insureds, shall include all automobiles utilized by Contractor's personnel in the performance of this Agreement, and shall be primary and not contributing with other insurance available to the Basin Transit.
4. Assignment - This agreement may not be assigned by the Contractor, in whole or in part, without

the prior written consent of Basin Transit.

5. Termination - This Agreement may be canceled by Basin Transit at any time without penalty upon thirty (30) days' written notice. In the event of termination without fault of Contractor, Basin Transit shall pay Contractor for all services rendered prior to date of termination, and such payment shall be in full satisfaction of all services rendered hereunder.

6. Worker's Compensation Insurance - In accordance with the provisions of Division 2, Part 7, Chapter 1, Article 5 (commencing with Section 1860) and Division 4, Part 1, Chapter 4 (commencing with Section 3700) of the Labor Code of the State of California, the Contractor is required to secure the payment of compensation to his employees and shall for that purpose obtain and keep in effect adequate Workers Compensation Insurance.

The undersigned Contractor is aware of the provisions of Section 3700 of the Labor Code which requires every employer to be insured against liability for worker's compensation or to undertake self insurance in accordance with the provisions of that Code, and will comply with such provisions before commencing the performance of the work of this contract.

7. General Rate of Per Diem Wages - Pursuant to the Labor Code of the State of California, the Director of Industrial Relations has determined the general prevailing rate of wages and employer payments for health and welfare, vacation, pension and similar purposes applicable to the work to be done. This rate and scale are on file with the General Manager and copies will be made available to any interested party on request. The Contractor to whom the contract is awarded, and the subcontractors under him must pay not less than these rates for this area to all workers employed in the execution of this contract.

8. Retention - In accordance with Part 5 (Section 2230), Division 2 of the Public Contract Code, a contractor may substitute securities for retention moneys withheld by a public agency to ensure performance under this contract. At the request and expense of the contractor, eligible securities equivalent to the amount withheld shall be deposited with the Basin Transit, or with a state or federally chartered bank, as the escrow agent, who shall then pay such moneys to the contractor, and upon satisfactory completion of the contract, the securities shall be returned to the Contractor.

9. Suit; Recovery of Attorney Fees & Costs - Should either party bring any action to protect or enforce its rights hereunder, the prevailing party in such action shall be entitled to recover, in addition to all other relief, its reasonable attorney fees and court costs.

10. Basin Transit Approval - All labor, materials, tools, equipment and services shall be furnished and work performed and completed under the direction and supervision and subject to the approval of Basin Transit or its authorized representatives.

11. Gratuities - Contractor warrants that neither it nor any of its employees, agents, or representatives has offered or given any gratuities or promises to Basin Transit's employees, agents, or representatives with a view toward securing this Contract or securing favorable treatment with respect thereto.

12. Conflict of Interest - Contractor warrants that he is and will continue to be in compliance with all applicable conflict of interest laws.

13. Contractor's Affidavit - After the completion of the work contemplated by this Contract, Contractor shall file with the General Manager his affidavit stating that all workmen and persons employed, all firms supplying materials, and all subcontractors upon the Job have been paid in full, and that there are no claims outstanding against the Project for either labor or materials, except certain items, if any, to be set forth in an affidavit covering disputed claims or items in connection with a Stop Notice which has been filed under the provisions of the laws of the State of California.

14. Notice to Basin Transit of Labor Disputes - Whenever Contractor has knowledge that any actual or potential labor dispute is delaying or threatens to delay the timely performance of the Contract, Contractor shall immediately give notice thereof, including all relevant information with respect thereto, to Basin Transit.
15. Books and Records - Contractor's books, records, and plans or such part thereof as may be engaged in the performance of this Contract, shall at all reasonable times be subject to inspection and audit by any authorized representative of the Basin Transit.
16. Legal Day's Work - Eight (8) hours labor constitutes a legal day's work.
17. Inspection - The work shall be subject to inspection and testing by Basin Transit and its authorized representatives.
18. Discrimination - Contractor represents that it has not, and agrees that it will not, discriminate in its employment practices on the basis of race, creed, religion, national origin, color, sex, age or handicap.
19. Governing Law - This Contract and any dispute arising hereunder shall be governed by the law of the State of California.
20. Written notice - Any written notice required to be given in any part of the Contract Documents shall be performed by depositing the same in the U.S. Mail, postage prepaid, directed to the address of the Contractor as set forth in the Contract Documents, and to the Basin Transit addressed as follows:

Ms. Cheri Holsclaw, General Manager
Basin Transit
62405 Verbena Road
Joshua Tree, California 92252
21. Clayton/Cartwright Acts Assignment - The Contractor agrees to assign to the Basin Transit all rights, title, and interest in and to all causes of action it may have under Section 4 of the Clayton Act (15 U.S.C. Sec. 15) or under the Cartwright Act (Chapter 2 (commencing with Section 16700) of Part 2 of Division 7 of the Business and Profession Code), arising from purchases of goods, services, or materials pursuant to the Public Works Contract. This assignment shall be made and become effective at the time the awarding body tenders final payment to the Contractor, without further acknowledgement by the parties.
22. Basin Transit Claims - Basin Transit does not waive any claims against Contractor by making any payment. The time limit for the Basin Transit to assert claims against Contractor shall not be limited by the Contract Documents but shall be in accordance with the laws of the State of California.

(Signatures on the following page)

Basin Transit – Bus Turnout and Shelter (IFB 24-01)

IN WITNESS WHEREOF, the parties hereto have executed the within Agreement the day and year first above written.

BASIN TRANSIT

General Manager

CONTRACTOR:

By: _____
Title:

By: _____
Title:

"Corporate seal"

APPENDIX

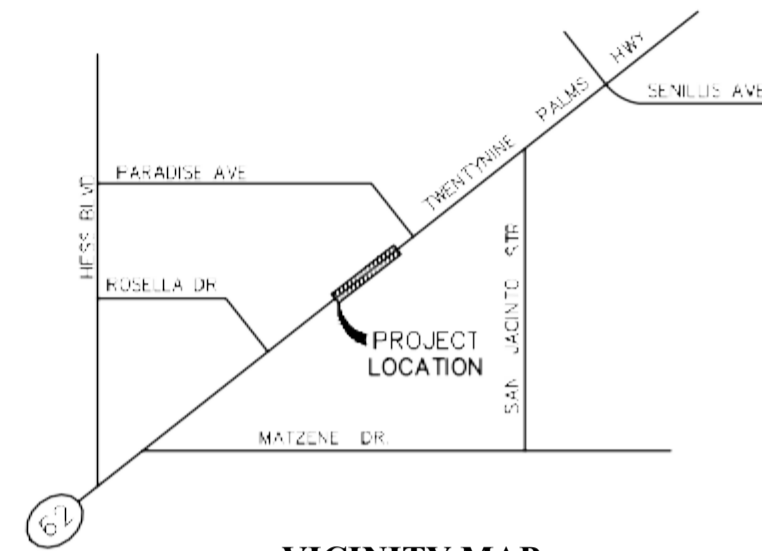

VICINITY MAP
NOT TO SCALE

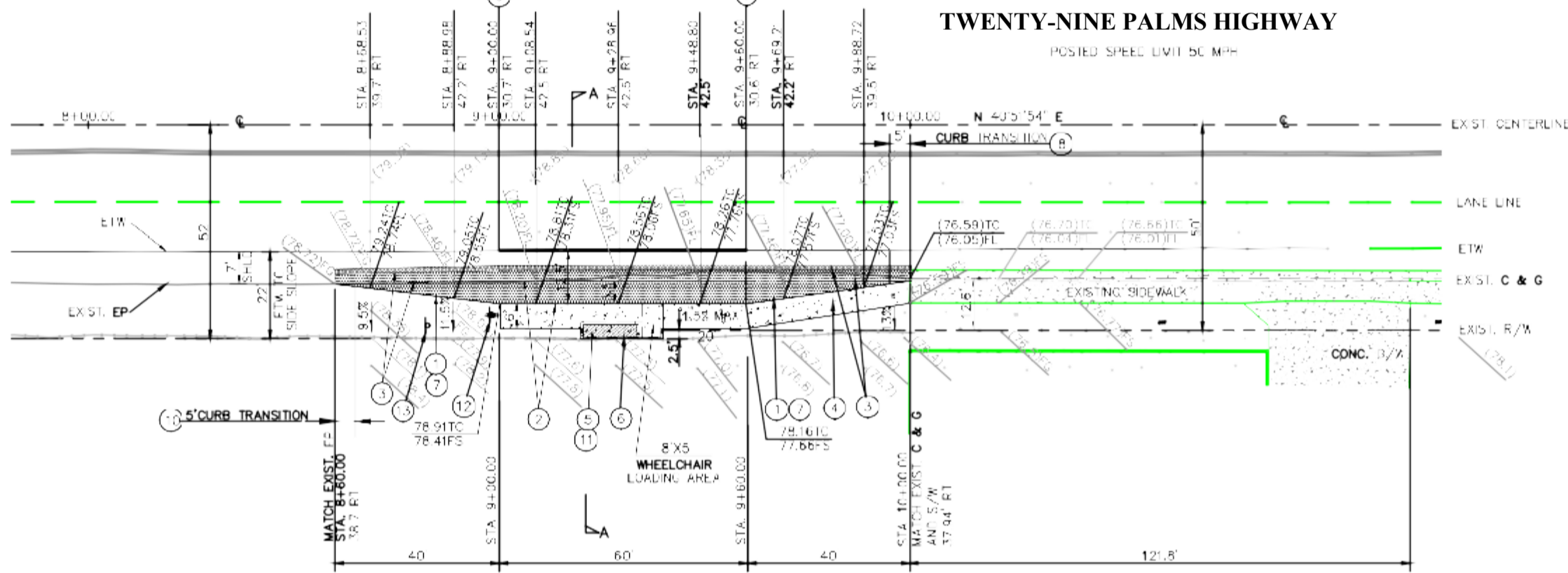

TWENTY-NINE PALMS HIGHWAY
POSTED SPEED LIMIT 50 MPH

CONSTRUCTION NOTES:

- | | | |
|----|--|--------------|
| 1 | 6" CURB PER CALTRANS STD PLAN AB7A, TYPE B1-6 CURB | 140 LF |
| 2 | 0.85 JPCP WITH DOWEL BARS AT TRANSVERSE JOINTS ON TOP OF 0.5' LEAN CONCRETE SUBBASE REFER TO CALTRANS HDW INDEX 626.4(3) | 760 SF |
| 3 | SAWCUT AND REMOVE EXISTING AC PAVEMENT 2.5' WIDE, REPLACE WITH FULL DEPTH TMA-A, 1' WIDE THICKNESS TO MATCH EXISTING | 350 SF/40 SF |
| 4 | 4" THICK 6" WIDE CONCRETE SIDEWALK (WIDTH MEASURED FROM BACK OF CURB TO BACK OF WALK) PER SCRD STD 109, TYPE C | 560 SF |
| 5 | 6" THICK CONCRETE BUS SHELTER PAD WITH WW-6X6 WOOD WIRE MESH AT MID HEIGHT | 80 SF |
| 6 | 6" THICK CONCRETE BLOCK SLOUGH WALL PER APWA STD. PLAN 622-4 | 20 LF |
| 7 | PAINT NEW CURB WITH RED PAINT PER CALTRANS SID. SPECS SECTION 84-2 | 140 LF |
| 8 | 5' CURB TRANSITION FROM 6" TO 8" CURB PER DETAIL | 5 LF |
| 9 | 8" CHANNELIZING LINE PER CALTRANS SID PLAN AZ02 DETAIL 35A | 60 LF |
| 10 | 5' AC CURE TRANSITION FROM 6" TO 0" | 5 LF |
| 11 | INSTALL BASIN TRANSIT FINISHED BUS SHELTER BENCH AND TRASH RECEPTACLE | 1 EA |
| 12 | INSTALL BASIN TRANSIT BUS STOP SIGN AND POST | 1 EA |
| 13 | RELOCATE EXISTING SPEED LIMIT SIGN AND POST | 1 EA |

QUANTITY:

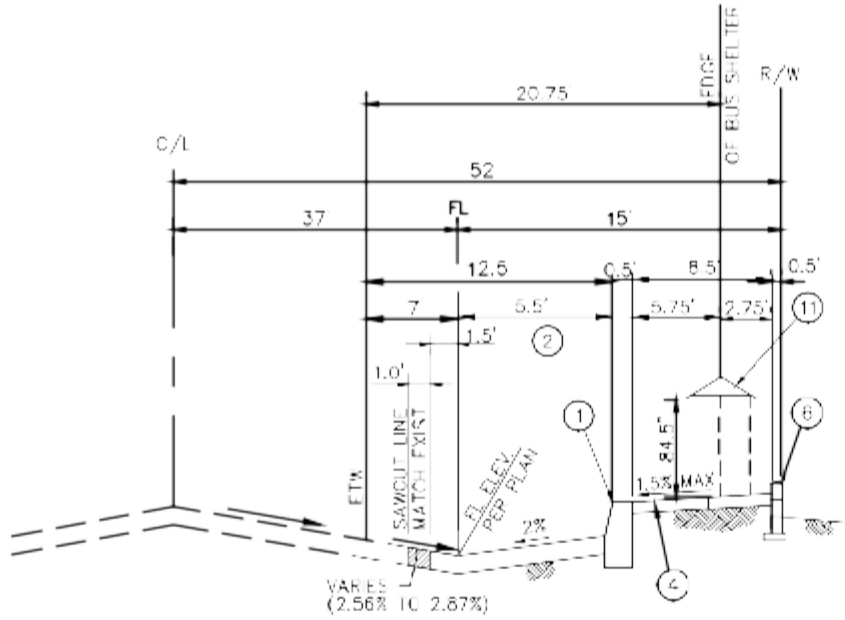

SECTION A
NOT TO SCALE

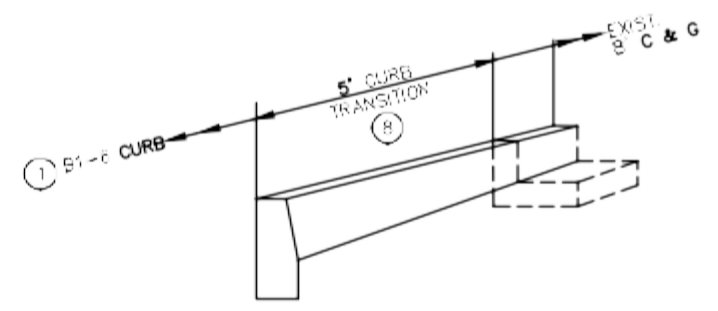

CURB TRANSITION DETAIL
FROM EXIST. 8" CURB AND GLITTER TO NEW 6"-6 CURB
NOT TO SCALE

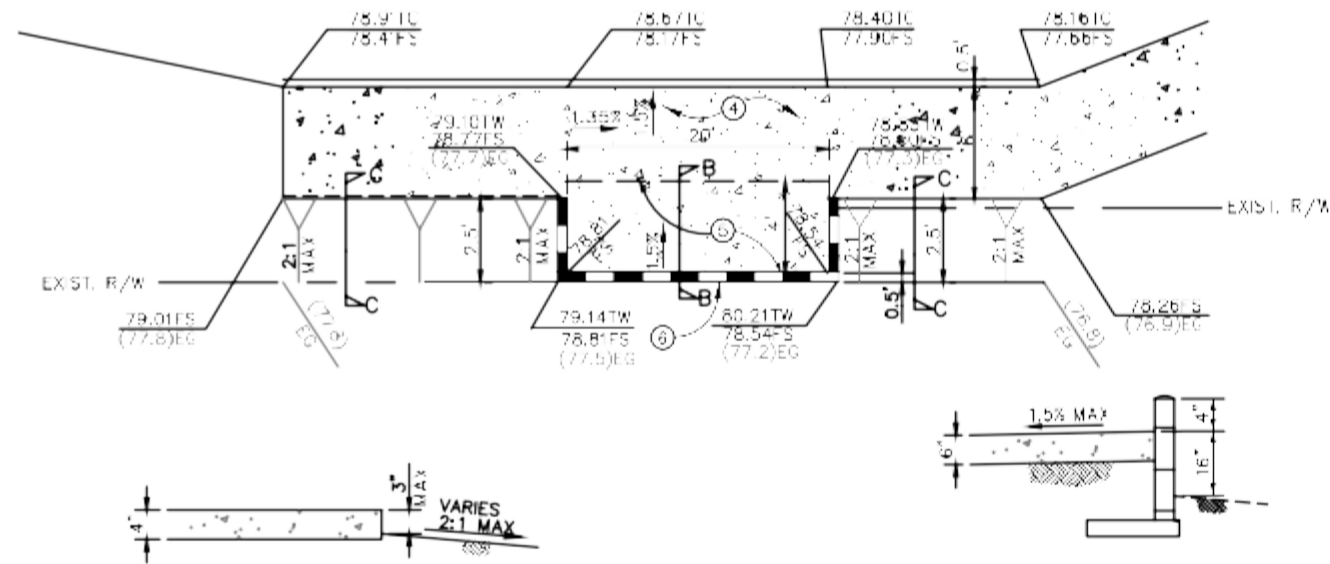

SECTION C

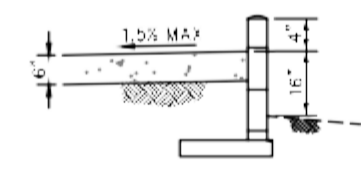

SECTION B

SLOUGH WALL
NOT TO SCALE

LEGEND:

- BW BACK OF WALK
- TC TOP OF CURB
- FL FLOW LINE
- FG FINISH GRADE
- FS FINISH SURFACE
- EG EDGE OF GUTTER
- RI RIGHT
- STA STATION
- 1BM TEMPORARY BENCHMARK

BENCHMARK

CALTRANS BM # 62.0.84-93
BRASS DISC IN CONCRETE
SELY SIDE OF 29 PALMS HIGHWAY
NELY OF INTERSECTION WITH PESS BLVD
ELEV.: 2590.70'

NOTE:
FOR ACCURATE RIGHT OF WAY DATA, CONTACT RIGHT OF WAY ENGINEERING AT THE LID RHC OFFICE (SEE RIGHT OF WAY MAP 75/82-03 AND AP MAP 0584-6)

ESTIMATE WORKING DAYS: 20 DAYS

Underground Service Alert
Call: TOLL FREE
1-800
227-2600
TWO WORKING DAYS BEFORE YOU DIG



CALTRANS PERMIT #

BASIN TRANSIT AUTHORITY
BUS TURNOUT AND SHELTER
MORONGO VALLEY POST OFFICE
TWENTYNINE PALMS HWY (SR-62)

SCALE: 1"=20'

SHEET 1 OF 1

BASIN TRANSIT

TO: Board of Directors
FROM: Cheri Holsclaw, General Manager
DATE: November 21, 2024

RE: Clean Energy Amended Agreement

Clean Energy supplies our CNG fueling station with renewable natural gas (RNG) and manages all the registration and reporting requirements to generate renewable identification numbers (RIN) credits under the Renewable Fuel Standard (RFS).

The Environmental Protection Agency (EPA) has released new regulations, referred to as the Biogas Regulatory Reform Rule (BRRR), that becomes effective January 1, 2025. These regulations apply to anyone producing, delivering, or using RNG at a CNG/LNG station, and are creating additional roles and responsibilities throughout the RIN lifecycle. Essentially, EPA is trying to get all parties in the RNG value chain to take on a more active role in the RFS program.

Basin Transit falls under the "RIN Separator" category as a CNG Station owner. The RIN Separator is responsible for receiving RINs from the RIN Owner/RNG Producer, completing monthly separations and remittance activities, and submitting quarterly RFS reports and annual attestations. All this will be performed via EPA's Central Data Exchange (CDX) and EPA Moderated Transaction System (EMTS) systems.

With this contract, Clean Energy will continue delivering RNG to our operation, seamlessly complete the BRRR setup process with EPA, and continue handling all the administrative tasks associated with delivering and validating RNG supply under the RFS program.

Counsel has reviewed and approved this agreement.

STAFF RECOMMENDATION: AUTHORIZE GENERAL MANAGER TO EXECUTE CLEAN ENERGY AMENDED AGREEMENT



Amendment to Transaction Confirmation(s)

[Date]

[Insert Recipient Name and Address]

RE: Amendment to Transaction Confirmation(s)

Dear _____,

Clean Energy Renewable Fuels, LLC (“**CERF**”) and [Morongo Basin Transit Authority] (together with CERF, each a “**Party**” and collectively, the “**Parties**”) have entered into one or more transaction confirmations for the purchase and sale of renewable natural gas (“**RNG**”) and associated environmental attributes. On July 12, 2023, the U.S. Environmental Protection Agency (“**EPA**”) published a final rulemaking known as the Biogas Regulatory Reform Rule, 88 Fed. Reg. 44468 (“**BRRR**”), that makes certain amendments to the regulations governing the U.S. Renewable Fuel Standard Program under the Energy Policy Act of 2005 and the Energy Independence and Security Act of 2007 (“**RFS**”) governing the generation of renewable identification numbers (“**RINs**”) on RNG. Due to the regulatory changes of the BRRR, by their execution of this letter (“**Letter Amendment**”) and as of the date of such execution, the Parties hereby agree to amend the following transaction confirmation(s) in the manner set forth herein:

1. **[MBTA001-TC02]** (as further amended, modified or supplemented from time to time)

(Collectively the “**Transaction Confirmation(s)**”).

Amendments to the Transaction Confirmation(s)

1. Maintaining the Benefits and Burdens of the Transaction Confirmation(s). The Parties acknowledge the changes and modifications to the RFS contained in the BRRR, the impact of which necessitates modifications to the Parties’ obligations under the Transaction Confirmation(s). The Parties hereby modify their respective responsibilities under the Transaction Confirmation(s) only to the extent necessary to comply with the BRRR, in a manner that is least disruptive to the legal and commercial terms of the Transaction Confirmation(s), and in a manner that preserves the original economic bargain and allocation of risks between the Parties as memorialized in the Transaction Confirmation(s), except as otherwise stated in this Letter Amendment.
2. Cooperation. The Parties agree that they shall cooperate with each other, share documentation and provide access to facilities owned or operated by each Party such that RINs can be validly generated under the RFS as amended by the BRRR. Such cooperation shall include, but is not limited to, sharing, completing and assisting the other Party or third parties with product transfer documents, affidavits, reports, records, measurement records, sampling and testing requirements of the RFS as amended by the BRRR.

3. Registration. The Parties acknowledge that the BRRR requires entities owning RNG or biogas on which RINs are generated to register with the EPA under the RFS in accordance with their respective roles. The Parties agree that while CERF shall register with the EPA in accordance with the BRRR, both Parties covenant that they will cooperate with one another to ensure the registration of all entities taking ownership of RNG and biogas used as a feedstock to produce RNG that is the subject of the Transaction Confirmation(s).
4. RIN Generator. The Parties agree that the producer of the RNG that is the subject of the Transaction Confirmation(s) shall be the generator of the RINs on the RNG as required by the RFS as amended by the BRRR.
5. RIN Separation. The Parties acknowledge that assigned RINs (known as “**K1 RINs**”) may not be separated from RNG and become separated RINs (known as “**K2 RINs**”) until the RNG is used as a transportation fuel as defined by the RFS. The Parties agree that CERF will separate K1 RINs into K2 RINs when the RNG is withdrawn from the natural gas commercial pipeline system or used or dispensed as transportation fuel at the Station(s) (as defined in the Transaction Confirmation(s)).
6. RIN Generation Rate. The Parties agree that if the Transaction Confirmation(s) establish a “RIN Generation Rate” (as defined in the Transaction Confirmation(s)), (i) the RIN Generation Rate shall equal 11.6935 beginning on January 1, 2025, and (ii) any reference to “11.727” in the formula for RIN Payment (as defined in the Transaction Confirmation(s)) shall be deemed deleted and replaced with “11.6935” beginning on January 1, 2025.
7. Other Necessary Amendments. To the extent not expressly addressed herein and recognizing that guidance and practical custom will be received by the EPA and will be developed by commercial parties during the implementation of the BRRR, the Parties shall without undue delay implement any other or further amendments, modifications, or changes reasonably necessary to conform their performance to the requirements of the BRRR. The Parties agree that if the Transaction Confirmation(s) contain a section titled “Regulatory Hinderance,” the Parties shall conduct their actions in accordance with the Regulatory Hinderance section.

If you are in agreement with the terms of this Letter Amendment, please sign below. This Letter Amendment may be executed in any number of counterparts or by electronic transmission (including pdf or any electronic signature complying with the U.S. federal ESIGN Act of 2000, e.g., DocuSign or EchoSign), each of which when so executed and delivered shall be deemed an original, and all of which together shall constitute one and the same instrument. The date of your signature below shall be the effective date of this Letter Amendment, and upon which the terms of this Letter Amendment shall become a binding agreement between the Parties.

Very truly yours,

Clean Energy Renewable Fuels, LLC

By: _____
Name: Robert Vreeland
Title: Chief Financial Officer

AGREED AND ACCEPTED:

[Morongo Basin Transit Authority]

By: _____
Name:
Title:
Date:

BASIN TRANSIT ACRONYM LIST

5309	Federal Transit Administration Capital Projects Grant Program
5310	Federal Transit Administration Grant Program for Elderly and Disabled
5311	Federal Transit Administration Rural Grant Program
5316	Job Access and Reverse Commute Grant Program
5339	Rural Discretionary Grant Program
5311f	Federal Transit Administration Intercity Bus Grant Program
CALACT	California Association for Coordinated Transportation
CALPERS	California Public Employees Retirement System
CALTIP	California Transit Insurance Pool
CALTRANS	California Department of Transportation'
CMAQ	Congestion Mitigation and Air Quality
CNG	Compressed Natural Gas
CTA	California Transit Association
DOT	Department of Transportation
FTA	Federal Transit Administration
IFB	Invitation for Bid
LAIF	Local Agency Investment Fund
LCTOP	Low Carbon Transit Operations Program
LTF	Local Transportation Funding
MBTA	Morongo Basin Transit Authority
PTIMSEA	Passenger Transportation Improvement Modernization & Service Acct.
RFP	Request for Proposal
SBCTA	San Bernardino County Transportation Authority
SGR	State of Good Repair
SRTP	Short Range Transit Plan
STA	State Transit Assistance
STIP	State Transportation Improvement Program
TAG	Transportation Assistance Grant Program
TREP	Transportation Reimbursement Escort Program
TSSDRA	Transit System Safety and Disaster Response Account

BASIN TRANSIT ROUTES

ROUTE 1	Highway Route Yucca Valley-Twenty-nine Palms
ROUTE 3A	Twenty-nine Palms-Base
ROUTE 3B	Twenty-nine Palms-Neighborhood
ROUTE 7A	North Yucca Valley
ROUTE 7B	South Yucca Valley
ROUTE 12	Palm Springs
ROUTE 15	Palm Springs Weekend
ROUTE 21	Landers
ROUTE 30 & 31	Yucca Valley Ready Ride
ROUTE 34	Twenty-nine Palms Ready Ride
ROUTE 36	Morongo Valley
ROUTE 50	Joshua Tree Ready Ride
ROUTE 1X	Highway Route Sunday Service