



# **Morongo Basin Transit Authority**

*Notice to Contractors, Instructions to Bidders, Special Provisions,  
Proposal & Contract for:*

## **BUS STOP AND SHELTER**

AT

**SR 62 AND ELK TRAIL**

**(IFB 19-01)**

## **MORONGO BASIN TRANSIT AUTHORITY**

### **Bus Stop and Shelter**

#### **INDEX TO DOCUMENTS**

	Section
Notice Inviting Sealed Bids	A-1 to A-2
Instructions To Bidders	B-1 to B-5
Special Provisions	C-1 to C-18
Proposal	D-1 to D-12
Performance Bond	E-1
Payment Bond	F-1 to F-2
Worker's Compensation Certificate of Insurance	G-1
Insurance Requirements	H-1
Instructions for Execution of Instruments	I-1
Contract	J-1 to J-4
Appendix:	
Bus Shelter Installation Instructions	
Bus Shelter Solar LED Lighting System Installation Instructions	
Caltrans Encroachment Permit	

**NOTICE INVITING SEALED BIDS  
MORONGO BASIN TRANSIT AUTHORITY**

**Bus Stop and Shelter (IFB 19-01)**

**BIDS MUST BE RECEIVED BY:** 10:00 a.m. on August 23, 2019

**BIDS TO BE OPENED BY:** 10:00 a.m. on August 23, 2019

**PLACE OF BID RECEIPT:** General Manager  
Morongo Basin Transit Authority  
62405 Verbena Road  
Joshua Tree, CA 92252

**NOTICE IS HEREBY GIVEN** that the Morongo Basin Transit Authority, County of San Bernardino, California, will receive up to, but not later than the time set forth above, sealed contract bids for the award of a contract for the above project. All bids shall be made on the form furnished by the Morongo Basin Transit Authority and shall be opened and publicly read aloud at the above-stated time at the place of bid receipt identified above.

Bids must be placed in a sealed package with the project name and identification number typed or clearly printed on the lower left corner of the package.

**PROJECT IDENTIFICATION NAME:** Bus Stop and Shelter

**DESCRIPTION OF WORK:** Provide necessary labor, equipment and materials to construct concrete curb and gutter, bus shelter pad, sidewalk, install MBTA furnished bus shelter, and associated work at SR 62 and Elk Trail, as specified on the drawings, and in these specifications and special provisions, and as directed by the General Manager.

**ENGINEER'S ESTIMATE:** \$55,000

**COMPLETION OF WORK:** All work shall be completed within 30 working days following written notice to proceed from the Morongo Basin Transit Authority.

**OBTAINING BID DOCUMENTS:** Contract documents for the above referenced project may be obtained at the Office of the General Manager, Morongo Basin Transit Authority, 62405 Verbena Road, Joshua Tree, California 92252, upon payment of **\$15.00** for each set if picked up in person, or **\$35.00** if mailed. Requests for mailing shall be made two weeks minimum prior to bid opening date to the Morongo Basin Transit Authority at (760) 366-2986. This amount is not refundable.

**BID BOND:** Each bid response shall be accompanied by the bid securities and attachments as required in Section B – Instructions to Bidders, in an amount not less than ten percent (10%) of the amount named in the bid.

**PREVAILING WAGE RATES:** Pursuant to the Labor Code of the State of California, the Director of Industrial Relations has determined the general prevailing rate of wages and employer payments for health and welfare, vacation, pension and similar purposes applicable to the work to be done. The General Prevailing Wage Determinations are available at <http://www.dir.ca.gov/OPRL/pwd/>. The Contractor to whom the contract is awarded, and the subcontractors under him must pay not less than these rates for this area to all workers employed in the execution of this contract.

**CONTRACTOR'S LICENSE:** In accordance with the Provisions of California Public Contract Code Section 3300, the Morongo Basin Transit Authority has determined that the Contractor shall possess a valid Class [A] General Engineering contractor's license at the time that the contract is awarded.

Failure to possess the specified license shall render the bid as non-responsive and shall act as a bar to award of the contract to any bidder not possessing said license at the time of award.

**SUBSTITUTE SECURITIES FOR RETENTION MONEYS:** In accordance with Part 5 (Section 22300), Division 2 of the Public Contract Code, a contractor may substitute securities for retention moneys withheld by a public agency to ensure performance under this contract. At the request and expense of the contractor, securities equivalent to the amount withheld shall be deposited with the Morongo Basin Transit Authority, or with a state or federally chartered bank, as the escrow agent, who shall then pay such moneys to the contractor, and upon satisfactory completion of the contract, the securities shall be returned to the Contractor.

**REJECTION OF BIDS:** The Morongo Basin Transit Authority reserves the right to reject any or all bids or any parts thereof and waive any irregularities or informalities in any bid or in the bidding and to make awards in all or part in the best interest of the Morongo Basin Transit Authority.

**WITHDRAWAL OF BID:** No bidder may withdraw his bid for a period of sixty (60) days after the date set for the opening bids.

**DEPARTMENT OF INDUSTRIAL RELATIONS REQUIREMENTS:**

- No contractor or subcontractor may be listed on a bid proposal for a public works project unless registered with the Department of Industrial Relations pursuant to Labor Code section 1725.5 [with limited exceptions from this requirement for bid purposes only under Labor Code section 1771.1(a)].
- No contractor or subcontractor may be awarded a contract for public work on a public works project unless registered with the Department of Industrial Relations pursuant to Labor Code section 1725.5.
- This project is subject to compliance monitoring and enforcement by the Department of Industrial Relations.
- Contractors and subcontractors must furnish electronic certified payroll records to the Labor Commissioner for all new projects awarded.

**MORONGO BASIN TRANSIT AUTHORITY**

By:   
\_\_\_\_\_  
Danny Chow  
Project Engineer

Date: July 26, 2019

## INSTRUCTION TO BIDDERS

**FORM OF PROPOSAL:** The proposal shall be made on the bidding schedule ("Proposal") herein. The proposal shall be enclosed in a sealed envelope bearing the name of the bidder and the name of the project as described under Section "A".

**DELIVERY OF PROPOSALS:** The proposal shall be delivered by the time and to the place stipulated in the Notice Inviting Sealed Bids. It is the bidder's sole responsibility to see that his proposal is received in proper time. Any proposal received after the scheduled closing time for receipt of proposals may be returned to the bidder unopened unless an extension has been granted by the Morongo Basin Transit Authority. Bidders or their authorized agents are invited to be present.

**MODIFICATIONS AND ALTERNATIVE PROPOSALS:** Unauthorized conditions, limitations or provisos attached to a proposal will render it informal and may be cause for rejection. The complete proposal forms shall be without inter-lineations, alterations or erasures, unless each such correction is suitably authenticated by affixing in the margin immediately opposite the correction the surname or surnames of the person or persons signing the bid. No oral, telegraphic or telephonic proposals or modifications will be considered.

**WITHDRAWAL OF PROPOSAL:** The proposal may be withdrawn upon request by the bidder without prejudice to himself prior to, but not after the time fixed for opening of bids, provided that the request is in writing, has been executed by the bidder or his duly authorized representative, and is filed with the General Manager. No proposal may be withdrawn during the period of sixty (60) calendar days after the opening of proposals.

**BIDDER'S SECURITY:** Each bid shall be accompanied by a certified or cashier's check payable to the Morongo Basin Transit Authority or a satisfactory bid bond in favor of the Morongo Basin Transit Authority executed by the bidder as principal and a satisfactory surety company as surety, in an amount not less than ten percent (10%) of the amount named in the bid. The check or bid bond shall be given as a guarantee that the bidder shall execute the contract if it is awarded to him in conformity with the contract documents and shall provide the evidence of insurance and furnish the necessary bonds as specified in the contract documents, within fifteen (15) calendar days after written notice of the award. In case of the bidder's refusal or failure to do so, the check or bond, as the case may be, shall be forfeited to the Morongo Basin Transit Authority. No bidder's bond will be accepted unless it conforms substantially to Section "D".

**APPROXIMATE ESTIMATE:** The quantities shown in the proposal form, and in the estimate included in the Special Provisions, shall be considered as approximate only, being listed therein for the purpose of serving as a general indication of the amount of work or materials to be performed or furnished, and as a basis for the comparison of bids; and the Morongo Basin Transit Authority does not guarantee nor agree, either expressly or by implication, that the actual amount required will correspond therewith, but reserves the right to increase or decrease the amount of any item or portion of work or material to be performed or furnished, or to omit any such item or portion, in accordance with the Special Provisions or Standard Specifications, under which the work is to be constructed, without any way invalidating the contract, should such increase, decrease or omission be deemed necessary or expedient.

**ADDENDA:** The General Manager may, from time to time, issue addenda to the contract documents during the period of advertising for bids, for the following purposes: (a) revising Prevailing Wage Scales, or (b) clarifying, correcting or otherwise amending quantities of work under Special Provisions, plans or bid proposal.

Securers of contract documents shall be notified of, and furnished with, copies of such addenda, either by certified mail or personal delivery, during the period of advertising at no additional cost.

**DISCREPANCIES IN PROPOSALS:** The bidder shall set forth each item of work, in clearly legible

figures, a unit or line item bid for the item in the respective spaces provided for this purpose.

In case of discrepancy between the unit price and the total set forth for the item, the unit price shall prevail, provided, however, if the amount set forth as a unit price is ambiguous, unintelligible or uncertain for any cause, or is omitted, or in the case where the unit price is the same amount as the entry in the "Total" column, then the amount set forth in the "Total" column for the item shall prevail in accordance with the following:

(1) As to lump sum items, the amount set forth in the "Total" column shall be the unit price.

(2) As to unit price items, the amount set forth in the "Total" column shall be divided by the estimated quantity for the item and the price thus obtained shall be the unit price.

In case of discrepancy between words and figures, the words shall prevail.

**COMPETENCY OF BIDDERS:** In selecting the lowest responsible bidder, consideration will be given not only to the financial standing, but also to the general competency of the bidder for the performance of the work covered by the proposal. To this end each proposal shall be supported by a statement of the bidder's experience on the form entitled "Information Required of Bidder" bound herein. No agreement for the work will be executed with a contractor who is not licensed in accordance with the laws of the State of California under applicable provisions of the Business and Professions Code. The licensing requirements for contractors shall apply also to subcontractors.

**BIDDER'S EXAMINATION OF SITE AND CONTRACT DOCUMENTS:** Bidders must satisfy themselves by personal examination of the location of the proposed work and by such other means as they may prefer as to the proposal, plans, specifications, contract form and actual conditions and requirements of the work, and shall not at any time after submission of the bid, dispute, complain, or assert that there was any misunderstanding in regard to the conditions to be encountered, the character, quality, and quantities of work to be performed and materials to be furnished, and the requirements of the proposal, plans, specifications, and the contract form. The submission of a proposal shall be considered conclusive evidence that the bidder has made such examination.

**DISQUALIFICATION OF BIDDERS:** No person, firm, or corporation shall be allowed to make, file or be interested in more than one bid for the same work, unless alternate bids are specifically called for. A person, firm or corporation that has submitted a subproposal to a bidder, or that has quoted prices of materials to a bidder is not hereby disqualified from submitting a subproposal or quoting prices to other bidders or making a prime proposal. If there is a reason to believe that collusion exists among the bidders, all bids will be rejected.

**RETURN OF BID SECURITY:** The successful bidder's proposal guarantee shall be held until the contract is executed. Bid security shall be returned to unsuccessful bidders within twenty (20) calendar days after the successful bidder has signed the contract.

**AWARD OF CONTRACT:** The Morongo Basin Transit Authority reserves the right to reject any or all bids or any parts thereof or to waive any irregularities or informalities in any bid or in the bidding. The award of the contract, if made by the Morongo Basin Transit Authority, will be to the lowest responsible and qualified bidder. The award, if made, will be within sixty (60) calendar days after the opening of the proposals; provided that the award may be made after said period if the successful bidder has not given the Morongo Basin Transit Authority written notice of the withdrawal of his bid.

**ALTERNATES:** In accordance with Public Contract Code Section 20103.8(b), the lowest bid shall be the lowest total of the bid price on the base bid plus any alternative bid item(s), and also providing that pursuant to that Section, the City reserves the right to deduct from the contract any alternative bid item(s).

**LISTING SUBCONTRACTORS:** Each bidder shall submit a list of the proposed subcontractors on this project, as required by the Subletting and Subcontracting Fair Practices Act (Public Contract Code

Sections 4100, et seq.). Forms for this purpose are furnished with the contract documents.

**EXECUTION OF AGREEMENT:** The bidder to whom award is made shall execute a written contract with the Morongo Basin Transit Authority in the form included in these contract documents and shall secure all insurance and bonds as herein provided within fifteen (15) calendar days from the date of mailing of written notice of the award. Failure or refusal to enter into the agreement or to conform to any of the stipulated requirements shall be just cause for the annulment of the award and forfeiture of the bidder's security. In the event the bidder to whom an award is made fails or refuses to execute the Agreement within said time, the Morongo Basin Transit Authority may declare the bidder's security forfeited, and it may award the work to the next lowest bidder, or may call for new bids.

If the successful bidder refuses or fails to execute the contract, the Morongo Basin Transit Authority may award the contract to the second lowest responsible bidder. If the second lowest responsible bidder refuses to execute the contract, the Morongo Basin Transit Authority may award the contract to the third lowest responsible bidder to execute the contract; such bidder's securities shall be likewise forfeited to the Morongo Basin Transit Authority.

**INSURANCE AND BONDS:** The Contractor shall not begin work under the Agreement until it has given the Morongo Basin Transit Authority evidence of comprehensive public liability insurance and Workers' Compensation Insurance coverage as provided in the General Provisions and Sections "G" and "H" and provided Faithful Performance and Labor and Material bonds as described in General Provisions and Sections "E" and "F".

**TELEPHONES:** Bidders are hereby notified that Morongo Basin Transit Authority will not provide telephones for their use at the time of receipt of bids.

**MATERIAL SUPPLIER:** If the firm who is signatory on the contract is supplying materials only, a payment bond need not be furnished.

**INTERPRETATION OF PLANS AND DOCUMENTS:** If any person contemplating submitting a bid for the proposed contract is in doubt as to the true meaning of any part of the drawings, specifications or other contract documents, or finds discrepancies in or omissions from the drawings and specifications, he may submit to the General Manager a written request for an interpretation or correction. The person submitting the request will be responsible for its prompt delivery. Any interpretation or correction of the contract document will be made only by an Addendum duly issued, and a copy of such Addendum will be mailed or delivered to each person receiving a set of the contract documents. No oral interpretation of any provision in the contract documents shall be binding.

**SALES AND/OR USE TAXES:** Except as may be otherwise specifically provided herein, all sales and/or use taxes assessed by federal, state or local authorities on materials used or furnished by the Contractor in performing the work hereunder shall be paid by the Contractor.

**DEPARTMENT OF INDUSTRIAL RELATIONS REQUIREMENTS:**

- No contractor or subcontractor may be listed on a bid proposal for a public works project unless registered with the Department of Industrial Relations pursuant to Labor Code section 1725.5 [with limited exceptions from this requirement for bid purposes only under Labor Code section 1771.1(a)].
- No contractor or subcontractor may be awarded a contract for public work on a public works project unless registered with the Department of Industrial Relations pursuant to Labor Code section 1725.5.
- This project is subject to compliance monitoring and enforcement by the Department of Industrial Relations.
- Contractors and subcontractors must furnish electronic certified payroll records to the Labor Commissioner for all new projects awarded.

**PROTEST PROCEDURES:** All protests must be in writing, stating the name and address of protestor, a contact person, Contract number and title. Protests shall specify in detail the grounds of the protest and the facts supporting the protest.

ADDRESS:

All protests must be addressed as follows:

Agency Contact: Mr. Mark Goodale  
For U.S. Mail, special delivery or hand delivery:  
Morongo Basin Transit Authority  
62405 Verbena Road  
Joshua Tree, CA 92252

Protests not properly addressed to the address shown above may not be considered by the Agency. Copies of the Agency's protest procedures and the protest provisions of FTA Circular 4220.1F or its successor may be obtained from Mr. Mark Goodale, General Manager, Morongo Basin Transit Authority, 62405 Verbena Road, Joshua Tree, CA 92252, [760-366-2986](tel:760-366-2986). Proposals shall be opened and a Notice of Award shall be issued by the Agency in accordance with the Agency's protest procedures and the protest provisions of FTA Circular 4220.1F or its successor.

PRE-PROPOSAL PROTESTS:

Pre-Proposal protests are protests based upon the content of the solicitation documents. Three copies of Pre-Proposal protests must be received by the Agency's office no later than ten (10) calendar days after the RFP is first advertised. Protests shall be considered and either denied or sustained in part or in whole, in writing, in a manner that provides verification of receipt, prior to the Due Date for Proposals. A written decision specifying the grounds for sustaining all or part of or denying the protest shall be transmitted to the protestor prior to the Due Date for Proposals in a manner that provides verification of receipt prior to the Due Date for Proposals. If the protest is sustained, the Proposal Due Date may be postponed and an addendum issued to the solicitation documents or, at the sole discretion of the Agency, the solicitation may be canceled. If the protest is denied, Proposals shall be received and opened on the scheduled date unless a protest is filed with FTA. See "FTA Review," below.

PROTESTS ON THE RECOMMENDED AWARD:

All proposers shall be notified of the recommended award. This notice shall be transmitted to each proposer at the address contained in its Proposal form in a manner that provides verification of receipt. Any Proposer whose Proposal has not lapsed may protest the recommended award on any ground not specified in "Pre-Proposal Protests," above. Three (3) copies of a full and complete written statement specifying in detail the grounds of the protest and the facts supporting the protest must be received by the Agency at the appropriate address in "Address," above, no later than fifteen (15) calendar days after the date such notification is received. Prior to the issuing of the Notice of Award, a written decision stating the grounds for allowing or denying the protest shall be transmitted to the protestor and the proposer recommended for award in a manner that provides verification of receipt.

CALTRANS REVIEW:

After such administrative remedies have been exhausted, an interested party may file a protest with the California Department of Mass Transportation pursuant to the procedures provided in the FTA C 4220.1F or its successor. Caltrans review is limited to the alleged failure of the Agency to have written protest procedures, the alleged failure of the Agency to follow those procedures, the alleged failure of the Agency to review a protest or the alleged violation of federal law or regulation.

The protest filed with Caltrans shall:

- 1) Include the name and address of the protestor.
- 2) Identify Morongo Basin Transit Authority as the party responsible for the RFP process.
- 3) Contain a statement of the grounds for protest and any supporting documentation. (The grounds for protest filed with Caltrans must be fully supported to the extent feasible. Additional materials in support of an initial protest will only be considered if authorized by the FTA regulations.)



Morongo Basin Transit Authority – Bus Stop and Shelter (IFB 19-01)

- 4) Include a copy of the protest filed with Morongo Basin Transit Authority, and a copy of Morongo Basin Transit Authority's decision, if any.
- 5) Indicate the ruling or relief desired from Caltrans.

Such protests should be sent to:

California Department of Transportation  
Division of Mass Transportation  
PO BOX 942874 – M.S. 39,  
Sacramento, CA 942874-0001

A copy of such protests should also be sent to the General Manager.

## **SPECIAL PROVISIONS**

### **Sub - Section 1. General Provisions**

The general provisions which shall apply to this contract shall be those set forth in the Standard Specifications for Public Works Construction, latest edition, published by Building News, Inc., 3055 Overland Avenue, Los Angeles, California 90034, hereinafter referred to as "Standard Specifications." The Standard Specifications are referred to and by this reference made a part hereof as though set forth at length. The Contractor is required to comply with the Standard Specifications in addition to the conditions set forth in these General Provisions, Specific Project Provisions and as stated in the Special Provisions of these contract documents.

#### **I. AWARD OF BID AND EXECUTION OF CONTRACT**

**I-A. DECISION AS TO WHICH CONTRACTOR IS THE LOWEST AND BEST BIDDER** - All bidders must submit with their proposals satisfactory evidence that they are capable of performing the work in accordance with plans and specifications. The General Manager may require any bidder bidding on any public improvement to submit experience records covering a three-year period. The Morongo Basin Transit Authority Board may reject the bid of any bidder who has been delinquent or unfaithful in the performance of any previous contract work. The decision of the Morongo Basin Transit Authority Board as to which bidder is considered the "lowest responsible bidder" will be based not only on the actual amount of the bid, but also on the relative competence and experience of the bidders, with particular regard to the quality performance of any work done by them for the Morongo Basin Transit Authority in the past, and such decisions shall be final and binding upon all parties.

**I-B. EXECUTION OF THE CONTRACT** - The contract, in the form set forth in Section "J" shall be executed by the successful bidder in accordance with the Instruction for Execution of Instruments, and returned to the Morongo Basin Transit Authority for execution by the Morongo Basin Transit Authority, and shall be accompanied by bonds as described in Paragraph I-C and the evidence of insurance required by Paragraph I-D, all within fifteen (15) calendar days from the date written notice of the award is mailed to bidder. No bidder proposal shall be considered binding upon the Morongo Basin Transit Authority until such time as it has been executed by the Morongo Basin Transit Authority.

**I-C. CONTRACT BONDS** - The successful bidder shall furnish to the Morongo Basin Transit Authority at his own expense two surety bonds. One bond shall be in the amount of 100% of the contract price in the form set forth in Section "E" to guarantee faithful performance of the contract work. The other bond, in an amount not less than 100% of the contract price in the form set forth in Section "F" shall be furnished to secure payment of those supplying labor and materials as required by the California Civil Code. Each bond shall be executed in accordance with the instructions set forth in Section "I" and each bond shall be executed by a corporate surety acceptable to, and approved by the Morongo Basin Transit Authority.

**I-D. INSURANCE** - The Contractor shall at all times, during the term of this contract, carry, maintain and keep in full force and effect, a policy or policies of comprehensive public liability insurance with an insurance company acceptable to, and approved by, the General Manager and Morongo Basin Transit Authority, within minimum limits of One Million Dollars (\$1,000,000.00) combined single limit coverage against any injury, death, loss or damage as a result of wrongful or negligent acts or omissions by the Contractor, together with an endorsement in substantially the form set forth in Section "H" attached hereto. The Contractor shall also at all times during the term of this contract carry, maintain and keep in full force and effect a policy or policies of Workers' Compensation insurance and shall provide to the Morongo Basin Transit Authority evidence of such coverage in the form set forth in Section "G" attached hereto.

**I-E. COMPLIANCE WITH PROVISIONS OF THE PUBLIC CONTRACT CODE** - All Contracts shall conform with the provisions of Sections 4100 through 4114, inclusive, of the Public Contract Code, as amended, concerning subcontractors and subcontracts.

**I-F. REJECTION OF BIDS** - Proposals may be rejected by the Morongo Basin Transit Authority Board where, upon evidence of a prior performance of the bidder, the Morongo Basin Transit Authority Board has made a finding that the bidder is not a responsible contractor because of unsatisfactory performance within the past three (3) years with the Morongo Basin Transit Authority or with other public entities. The Morongo Basin Transit Authority reserves the right to reject any or all bids and to waive any irregularity or informality in any bid to the extent permitted by law.

## **II. LEGAL RELATIONS AND RESPONSIBILITY TO THE MORONGO BASIN TRANSIT AUTHORITY**

**II-A. LAWS TO BE OBSERVED** - The Contractor shall keep himself fully informed on all existing and pending State and national laws and all municipal ordinances and regulations of the Morongo Basin Transit Authority, which in any manner affect those employed in the work, or the material used in the work, or which in any way affect the conduct of the work, and of all such orders and decrees of bodies or tribunals having jurisdiction or authority over the same. The Contractor shall particularly observe all ordinances of the Morongo Basin Transit Authority in relations to the obstruction of streets or conduct of the work, keeping open passageways and protecting the same where they are exposed or dangerous to traffic.

**II-B. SOCIAL SECURITY REQUIREMENTS** - The Contractor shall furnish to the Morongo Basin Transit Authority satisfactory evidence that he and all subcontractors working for him are complying with all requirements of the Federal and State Social Security legislation. The Contractor, at any time on request, shall satisfy the Morongo Basin Transit Authority that the Social Security and Withholding tax are being properly reported and paid.

**II-C. PREVAILING WAGES** - In accordance with the provisions of Section 1770 *et seq.*, of the Labor Code, the Director of the Department of Industrial Relations of the State of California has ascertained the general prevailing rate of wages applicable to the work to be done under contract for public improvement. The Contractor will be required to pay to all those employed on the project sums not less than the sums set forth in the documents entitled "General Prevailing Wage Determination made by the Director of Industrial Relations pursuant to California Labor Code Part 7, Chapter 1, Article 2, Sections 1770, 1773, 1773.1 and 1776."

The Contractor shall post a copy of the prevailing wage rates at each job site.

**II-D. PENALTIES** - The Contractor shall comply with Labor Code Section 1775 and he shall forfeit, as a penalty to the Morongo Basin Transit Authority, the sum of not more than fifty dollars (\$50.00) as determined by the labor commissioner, for each calendar day or portion thereof during which the Contractor or any subcontractor under him has paid to any workman employed in the project an amount less than that required by the provisions of the preceding Paragraph II-C.

**II-E. WORKING HOURS** - The Contractor shall forfeit, as penalty to the Morongo Basin Transit Authority, the sum of twenty-five dollars (\$25.00) for each workman employed in the execution of the contract by him or by any subcontractor under him for each calendar day during which such worker is required or permitted to work more than eight (8) hours in any one calendar day and forty (40) hours in any one calendar week, in violation of the provisions of Labor Code Section 1813.

**II-F. APPRENTICES** - Attention is directed to the provisions of Sections 1777.5 and 1777.6 of the Labor Code concerning the employment of apprentices by the Contractor or any subcontractor under him. It shall be Contractor's responsibility to ensure that all persons shall comply with the requirements of said sections in the employment of apprentices.

Information relative to apprenticeship standards and administration of the apprenticeship program may be obtained from the Department of Industrial Relations, San Francisco, California, or from the Division of Apprenticeship Standards and its branch offices.

**II-G. REGISTRATION OF CONTRACTORS** - Only a Contractor licensed in accordance with the provisions of Chapter 9, Division 3, of the Business and Professions Code, beginning at Section 7000, shall be permitted to enter into a contract with the Morongo Basin Transit Authority for any public improvements.

**II-H. PERMITS AND LICENSES** - The Contractor shall procure all permits and licenses, (including a business license of the City or Town in which the project is located, if required), pay all charges and fees and give all notices necessary and incidental to the due and lawful prosecution of the work.

**II-I. PATENTS** - The Contractor shall assume all responsibility arising from the use of any patented, or allegedly patented materials, equipment, devices or processes used on or incorporated in the work, and shall defend, indemnify, and hold harmless the Morongo Basin Transit Authority, and each of its officers, agents, and employees from and against any and all liabilities, demands, claims, damages, losses, costs, and expenses, of whatsoever kind or nature, arising from such use.

**II-J. INDEMNITY** - The Contractor agrees to defend, indemnify, and save harmless the Morongo Basin Transit Authority and each of its officers, agents, and employees and agents including but not limited to the firm, its officers and employees of Charles Abbott Associates, Inc. who are providing services to the Morongo Basin Transit Authority from and against any and all liabilities, demands, claims, damages, losses, costs, and expenses, of whatsoever kind or nature, including, but not limited to, any and all direct and indirect consequence of entering into this contract or of injury, sickness, or disease, including death, to persons or injury to, or destruction of, property, including, but not limited to, the loss of use of property, resulting directly or indirectly from or in any manner connected with or pertaining to any and all operations, and any and all activities, omissions and conditions in any manner connected therewith or pertaining thereto, of the Contractor under the contract, subject to any limitations imposed by Civil Code Section 2782.

**II-K. NOTICE** - The address given in the Contractor's proposal is the place to which all notices to the Contractor shall be mailed or delivered. The mailing to or delivering at the above named place of any notice shall be deemed sufficient service thereof upon the Contractor, and the date of that service shall be the date of such mailing or delivery. Such address may be changed at any time by written notice signed by the Contractor and delivered to the General Manager.

**II-L. CONTRACTOR'S RESPONSIBILITY FOR WORK** - Until the final acceptance of the work by the Morongo Basin Transit Authority, by written action of the General Manager, the Contractor shall have the charge and care thereof and shall bear the risk of injury or damage to any part of the work by the action of the elements or any other cause. The Contractor shall rebuild, repair, restore and make good all injuries or damages to any portion of the work occasioned by any cause before its completion and acceptance and shall bear the expense thereof, except for such injuries or damages arising from the sole negligence of willful misconduct of the Morongo Basin Transit Authority, its officers, agents or employees. In the case of suspension of work from any cause whatever, the Contractor shall be responsible for all materials and the protection of work already completed and shall properly store and protect them if necessary and shall provide suitable drainage and erect temporary structures where necessary.

**II-M. MAINTENANCE AND GUARANTEE -**

(1) The Contractor hereby guarantees that the entire work constructed by him under the contract will meet fully all requirements as to quality of workmanship and materials. The Contractor hereby agrees to make at his own expense any repairs or replacements made necessary by defects in materials or workmanship that become evident within one year after the date of the final payment, and to restore to full compliance with the requirements of these specifications including any test requirements set forth herein for any part of the constructed hereunder, which during said one-year period is found to be deficient with respect to any provisions of the specifications. The Contractor shall make all repairs and replacements promptly upon receipt of written orders for the same from the General Manager.

(2) The guarantees and agreements set forth in Subsection 1 shall be secured by a surety bond which

shall be delivered by the Contractor to the Morongo Basin Transit Authority before the Notice of Completion and acceptance of the work, by the General Manager, as provided in Subsection 6-8 of the Standard Specifications. Said bond shall be in the form approved by the Morongo Basin Transit Authority and executed by a surety company or companies satisfactory to the Morongo Basin Transit Authority, in the amount of 100% of the contract. Said bond shall remain in force for a period of one year after the date of Notice of Completion and acceptance. Alternatively, the Contractor may provide for the Faithful Performance Bond furnished under the contract to remain in force and effect for said amount until the expiration of said one-year period.

### **III. PROSECUTION AND PROGRESS OF THE WORK**

**III-A. WORK SCHEDULE** - As soon as notified of the award of the contract, the Contractor shall prepare and submit to the General Manager a work schedule for accomplishing the work. Said schedule must show the dates of the expected start and completion of the various items of the contract work. During a scheduling conference between the Contractor and the General Manager, the work schedule will be discussed and modified, if necessary, by mutual agreement. Should it become necessary for the Morongo Basin Transit Authority to delay temporarily the work schedule agreed upon during the scheduling conference, every effort will be made to permit a new work schedule at the time most convenient to the Contractor, thus permitting the project to proceed with the shortest intramural movement of the equipment.

**III-B. SUBLETTING AND ASSIGNMENT** - The Contractor shall give his personal attention to the fulfillment of the contract and shall keep the work under his control. The Contractor shall not assign, transfer nor sublet any part of the work without the written consent of the Morongo Basin Transit Authority by the General Manager and of the surety of the Contractor's bond, and such consent of Surety, together with a copy of the subcontract, shall be filed with the General Manager. No assignment, transfer or subletting, even though consented to, shall relieve the Contractor of his liabilities under the contract. Subcontractors shall not be recognized as such, and all persons engaged in the project will be considered as employees of the Contractor, their work being subject to the provisions of the contract and the specifications. Should any subcontractor fail to perform the work undertaken by him to the satisfaction of the General Manager, said subcontractor shall be removed immediately from the project upon request by the General Manager, shall not again be employed on the work, and the Contractor shall be held liable for the deficient work.

The Contractor shall submit to the Morongo Basin Transit Authority a list with the names, addresses and telephone numbers of all subcontractors who will work under him.

**III-C. CHARACTER OF WORKMAN** - The Contractor shall employ none but competent foremen, laborers and mechanics. Any overseer, superintendent, laborer or other person employed on the work by the Contractor who is intemperate, incompetent, troublesome or otherwise undesirable, or who fails or refuses to perform the work in the manner specified herein, shall be discharged immediately and such person shall not again be employed on the work.

**III-D. AGENTS OR FOREMAN** - In the absence of the Contractor from the site of the project, even if such is only of a temporary duration, he must provide and leave at the site a competent and reliable English-speaking agent or foreman in charge. All notices, communications, orders or instructions given, sent to, or served upon, such agent or foreman by the General Manager shall be considered as having been served upon the Contractor.

**III-E. TEMPORARY STOPPAGE OF CONSTRUCTION ACTIVITIES** - The General Manager shall have the authority to suspend the contract work, wholly or in part, for such a period of time as he may deem necessary, due to unsuitable weather, or to such other conditions as he considered unfavorable for the proper prosecution of the work, or for such time as he may deem necessary due to failure on the part of the Contractor or his workmen to carry out orders or to perform any of the requirements of the contract. The Contractor shall immediately comply with such an order from the General Manager and shall not resume operations until so ordered in writing.

**III-F. TIME OF COMPLETION AND LIQUIDATED DAMAGES** - If all the contract work is not completed in all parts and requirements within the time specified in the contract documents, the Morongo Basin Transit Authority shall have the right to grant or deny an extension of time for completion, as may seem best to serve the interest of the Morongo Basin Transit Authority. The Contractor shall not be assessed with liquidated damages during any delay in the completion of the work caused by acts of God or of the Public Enemy, acts of the State, fire not due to acts of contractors, of subcontractors, floods, epidemics, quarantine, restrictions, strikes, freight embargo or unusually severe weather, or delays of subcontractors due to such causes, provided that the Contractor shall, within ten (10) days from the beginning of such delay, notify the Morongo Basin Transit Authority, in writing, of the cause of the delay. The Morongo Basin Transit Authority will ascertain the facts and the extent of the delay, and the finding thereon shall be final and conclusive. If the Morongo Basin Transit Authority deems it appropriate to assess the contractor liquidated damages, such damages shall be of a minimum amount of \$250.00 per day.

**III-G. SUSPENSION OF CONTRACT** - If at any time, in the opinion of the General Manager, the Contractor fails to supply an adequate working force, manufactured articles, or material of proper quality, or has failed in any other respect to prosecute the work with the diligence and force specified and intended in any by the terms of the contract, notice thereof in writing will be served upon him, and should he neglect or refuse to provide means for a satisfactory compliance with the contract within the time specified in said notice and as directed by the General Manager, the General Manager shall have the power to suspend the operation of the contract and discontinue all work or any part thereof, subject to review by the Morongo Basin Transit Authority Board. Thereupon the Contractor shall discontinue such work, or such part thereof as the Morongo Basin Transit Authority may designate, and the Morongo Basin Transit Authority may thereupon, by contract or otherwise, as it may determine, complete the work or such part thereof, and charge the entire expense of so completing the work or any part thereof to the Contractor, and for such completion the Morongo Basin Transit Authority itself or its Contractors may take possession of and use, or cause to be used in the completion of the work, or any part thereof, any such materials, implements and tools of every description as may be found at the place of such work. All expense charged under this paragraph shall be deducted and paid for by the Morongo Basin Transit Authority out of any moneys then due or to become due the Contractor under the contract, or any part thereof, and in such accounting the Morongo Basin Transit Authority shall not be held to obtain the lowest figure for the work for completing the contract, or any part thereof, or for ensuring its proper completion, but all sums paid therefore shall be charged to the Contractor. In case the expenses so charged are less than sum which would have been payable under the contract, if the same had been completed by the Contractor, the Contractor shall be entitled to receive the difference, and in case such expense shall exceed the amount payable under the contract, then the Contractor shall pay the amount of the excess to the Morongo Basin Transit Authority, upon completion of the work, without further demand being made therefore. In the determination of the question as to whether or not there has been any such noncompliance with the contract as to warrant the suspension or annulment thereof, the decision of the Morongo Basin Transit Authority Board shall be binding on all parties to the contract.

#### **IV. MEASUREMENT AND PAYMENT**

**IV-A. MEASUREMENT AND PAYMENT** - Measure of the quantities of work and payments therefore shall be in accordance with Section 9 of the Standard Specifications. In accordance with Subsection 9.2 of the Standard Specifications, the monthly payment date shall be the last calendar day of each month. A measurement of work performed and a progress estimate of the value thereof based on the contract and of the monthly payment shall be prepared by the Contractor and submitted to the General Manager before the tenth day of the following month for verification and payment consideration.

#### **IV-B. FINAL INVOICE AND PAYMENT –**

(1) Whenever in the opinion of the General Manager, the Contractor shall have completely performed the contract on his part, the General Manager shall notify the Morongo Basin Transit Authority that the contract has been completed in its entirety. The Contractor shall then submit to the General Manager for approval, a written statement of the final quantities of contract items for inclusion in the final invoice.

Upon receipt of such statement, the General Manager shall check the quantities included therein and shall authorize the Contractor to submit an invoice which in the General Manager's opinion shall be just and fair, covering the amount and value of the total amount of work done by the Contractor, less ten percent (10%) of the total work done. The General Manager shall then request that the Morongo Basin Transit Authority accept the work and that the General Manager be authorized to file, on behalf of the Morongo Basin Transit Authority in the office of the San Bernardino County Recorder, a Notice of Completion of the work herein agreed to be done by the Contractor.

(2) On the expiration of thirty-five (35) days after the date of recording the Notice of Completion, the Morongo Basin Transit Authority shall pay to the Contractor the amount remaining after deducting from the amount of value stated in the invoice all prior payments to the Contractor and all amounts to be kept and retained under the provisions of the contract, and shall release the Faithful Performance Bond and Labor and Material Bond.

(3) Substitution of Securities for Retention: In accordance with Public Contract Code Section 22300, the Contractor may substitute securities for retention moneys to be withheld to ensure performance under this contract. At the request and expense of the Contractor, securities equivalent to the amount withheld may be deposited with the Morongo Basin Transit Authority, or with an approved state or federally chartered bank as the escrow agent, who shall then pay such moneys to the Contractor, and upon satisfactory completion of the contract, the securities shall be returned to the contractor. It is the Contractor's obligation to secure the services of a state or federally chartered bank to act as escrow agent. Securities eligible for investment include those listed in Government Code Section 16430 or bank or savings and loan certificates of deposit, interest bearing demand deposit accounts, standby letters of credit or any other security mutually agreed to by the Contractor and the Morongo Basin Transit Authority. Contractor shall be the beneficial owner of any securities for retention moneys withheld and shall receive any interest earned by the securities.

**IV-C. EXTRA WORK** - Extra work, when ordered in writing by the General Manager and accepted by the Contractor, shall be paid for under written work order in accordance with the terms therein provided. Payment for extra work will be made at the unit price or lump sum previously agreed upon between the Contractor and the General Manager. All extra work shall be adjusted daily upon report sheets prepared by the General Manager, furnished by the Contractor, and signed by both parties, and said daily report shall be considered thereafter the true records of extra work done.

**IV-D. UNPAID CLAIMS** - If upon or before the completion of the work herein agreed to be performed or at any time prior to the expiration of the period within which claims of lien may be filed for record as prescribed by the Code of Civil Procedure of the State of California, any person or persons claiming to have performed any labor or furnished any materials, supplies or services towards the performance of completion of this contract or if they have agreed to do so, shall file with the Morongo Basin Transit Authority a verified statement of such claim, or if any person shall bring against the Morongo Basin Transit Authority or any of its agents any action to enforce such claim, the Morongo Basin Transit Authority shall until the discharge thereof, withhold from the moneys that are under its control, as much as shall be sufficient to satisfy and discharge the amount in such notice or under such action claimed to be due, together with the cost thereof; provided, that if the Morongo Basin Transit Authority shall in its discretion permit the Contractor to file such additional bond as is authorized by the Code of Civil Procedure in a penal sum equal to one and one-quarter times the amount of said claim, said money shall not thereafter be withheld on account of such claim.

**IV-E. ACCEPTANCE** - The parties agree that no certificate given shall be conclusive evidence of the faithful performance of the contract, either in whole or in part, and that no payment shall be construed to be in acceptance of any defective work or improper materials. Further, the certificate or final payment shall not terminate the Contractor's obligations under his warranty hereinabove. The Contractor agrees that payment of the amount due under the contract and the adjustments and payments due for any work done in accordance with any alterations of the same, shall release the Morongo Basin Transit Authority, the Morongo Basin Transit Authority Board and its officers and employees from any and all claims or liability on account of work performed under the contract or any alteration thereof. (Section 7100, Public

Contract Code)

## **V. CONTROL OF WORK**

**V-A. AUTHORITY OF THE GENERAL MANAGER** - The General Manager shall decide any and all questions that may arise as to the quality and acceptability of materials furnished and work performed as to the manner of performance and rate of progress of the work, and any and all questions which may arise as to the interpretation of the plans and specifications. The General Manager shall likewise decide any and all questions as to the acceptable fulfillment of the contract on the part of the Contractor, and all questions as to claims and compensations. The decision of the General Manager shall be final, and he shall have relative authority to enforce and make effective such decisions and actions as the Contractor fails to carry out promptly.

**V-B. CONFORMITY WITH PLANS AND ALLOWABLE VARIATION** - Finished surfaces shall in all cases conform with the lines, grades, cross-sections and dimensions shown on the plans. Minor deviations from approved plans, whenever required by the exigencies of construction, shall be determined in all cases by the General Manager and authorized in writing.

**V-C. PROGRESS OF THE WORK** - The Contractor shall begin work on the date agreed upon following the scheduling conference mentioned in Paragraph III-A hereof, and shall diligently prosecute the same to completion before the expiration of the time limit appearing in the specifications.

**V-D. SAMPLES** - The Contractor shall furnish all products and materials required to complete the work. All materials and products must be of the specified quality and fully equal to samples, when samples are required. Whenever required, the Contractor shall submit to the General Manager for test, and free of charge, samples of any one of the materials or products proposed to be used in the work. Said samples shall be delivered by the Contractor to the place within the Morongo Basin Transit Authority designated by the General Manager. Rejected material must be immediately removed from the work by the Contractor and shall not again be brought back to the site.

**V-E. TRADE NAMES AND ALTERNATIVES** - For convenience in designation on the plans or in the specifications, certain equipment or articles or materials to be incorporated in the work may be designated under a trade name of manufacturer and his catalog information. The use of an alternative equipment or an article or equipment which is of equal quality and of the required characteristics for the purpose intended will be permitted, subject to the approval of the General Manager, in accordance with the following required by Section 3400 of the Public Contract Code of the State of California.

The burden of proof as to the comparative quality and suitability of alternative equipment or articles or materials shall be upon the Contractor, and he shall furnish, at his own expense, all information necessary or related thereto as required by the General Manager. The General Manager shall be the sole judge as to the comparative quality and suitability of alternative equipment or articles or materials and his decision shall be final. All requests for substitution shall be submitted seven (7) days in advance of bid opening to permit, if the request is approved, an addendum to be issued to all bidders.

**V-F. PROTECTION OF WORK** - The Contractor shall continuously maintain adequate protection of all his work from damage, and the Morongo Basin Transit Authority will not be held responsible for the care or protection of any material, equipment or parts of work, except as expressly provided for in the specifications.

**V-G. CONFLICT OF TERMS** - The notice to bidders, proposal, plans, specifications and General Provisions are essential parts of the contract for a given project. These documents, together with the necessary bonds and bidder's guarantee, constitute the contract as defined herein, and a requirement included in one document shall be as binding as though included in all, as they are intended to be cooperative and to provide a description of the work to be done. Should there be any conflict or discrepancy between terms used, then the specifications shall govern over plans, and change orders and supplemental agreements shall govern over any other contract document.



**V-H. INTERPRETATION OF PLANS AND SPECIFICATIONS** - Should it appear that the work to be done, or any matter relative thereto, is not sufficiently detailed or explained on the plans or in the specifications, the Contractor shall request the General Manager for such further explanation as may be necessary, and shall conform to such explanation or interpretation as part of the contract, so far as may be consistent with the intent of the original specifications. In the event of doubt of questions relative to the true meaning of the specifications, reference shall be made to the Morongo Basin Transit Authority Board, whose decision thereon shall be final.

**V-I. ALTERATIONS, INCREASES AND DECREASES OF WORK TO BE DONE** - The Morongo Basin Transit Authority reserves the right to increase or decrease the quantity of any item or portion of the work described on the plans, the specifications or the proposal form or to omit portions of the work so described, as may be deemed necessary or expedient by the General Manager and the Contractor shall agree not to claim or bring suit for damages, whether for loss of profits or otherwise, on account of any decrease or omission of any kind of work to be done. By mutual consent of the parties signatory to the contract, alterations, modifications or deviations from the type of work may be described on the plans, specifications or on the proposal form may be made without in any way making the contract void. The price to be paid by the Morongo Basin Transit Authority to the Contractor for such altered or modified work shall be agreed upon in writing, endorsed upon the original contract and signed by the proper parties to said contract.

Whenever, during the progress of the work, such changes or modifications are deemed necessary by the General Manager and agreed upon, as aforesaid, said deviations shall be considered and treated as though originally contracted for, and shall be subject to all the terms, conditions and provisions of the original contract.

**V-J. EXTRA WORK** - New and unforeseen work will be classed as extra work only when said work is not covered and cannot be paid for under any of the various items or combination of items for which a bid price appears on the proposal form. The Contractor shall not do any extra work except upon written order from the General Manager. Compensation for such extra work shall be previously agreed upon in writing between the Contractor and the General Manager.

**V-K. LINES AND GRADES** - Except when, as per orders from the General Manager, minor changes in the work are to be made by the Contractor, all work shall, during its progress and upon completion, conform to the lines, grades and elevations shown on the plans. All distances and measurements are given thereon and will be made in a horizontal plane. Three (3) consecutive points shown on the same rate of slope must be used in common in order to detect any variation from a straight line, and in case any such discrepancy exists, it must be reported to the General Manager. Failure to make this report shall make the Contractor responsible for any error in the finished work.

**V-L. PUBLIC UTILITIES -**

(1) All of the existing utility facilities except those to be relocated as shown on the plans will remain in place and the contractor will be required to work around said facilities. In case it should be necessary to remove the property of a public utility or franchise, such owner will, upon proper application by the Contractor, be notified by the General Manager to move such property within a reasonable time, and the Contractor shall not interfere with said property until after the expiration of the time specified. The right is reserved to the owners of public utilities or franchises to enter upon the streets for the purpose of making repairs or changes in their property which may be necessary as a result of the work. Employees and agents of the Morongo Basin Transit Authority shall likewise have the privilege of entering upon the street for the purpose of making any necessary repairs or replacements.

(2) The Contractor shall employ and use only qualified persons, as hereinafter defined, to work in proximity to Southern California Edison secondary, primary and transition facilities. The term "qualified person" shall mean one, who by reason of experience or instruction, is familiar with the operation to be formed and the hazards involved, as more specifically defined in Section 2700 of Title 8 of the California

Administrative Code. The Contractor shall take such steps as are necessary to assure compliance by any subcontractors.

**V-M. REMOVAL OF INTERFERING OBSTRUCTIONS** - The Contractor shall remove and dispose of all debris, abandoned structures, tree roots and obstructions of any character met during the process of excavation, it being understood that the cost of said removals are made a part of the unit price bid by the Contractor under the item for excavation or removal of existing work.

**V-N. PROCEDURE IN CASE OF DAMAGE TO PUBLIC PROPERTY** - Any portions of curb, gutter, sidewalk or any other Morongo Basin Transit Authority improvement damaged by the Contractor during the course of construction shall be replaced by the Contractor at his own cost, free of charges to the Morongo Basin Transit Authority. The cost of additional replacement of curb, gutter or sidewalk in excess of the estimated quantities shown in the proposal form and specifications, and found necessary during the process of construction, (but not due to damage resulting from carelessness on the part of the Contractor during his operation), shall be paid to the Contractor at the unit prices submitted in his bid.

**V-O. AVOIDANCE OF DUST NUISANCE** - During the process of breaking, excavating and removing any material from the site of the project and until completion of the work, the Contractor shall take every precaution to avoid the nuisance of unnecessary dust by using any measures advocated by the General Manager.

**V-P. REMOVAL OF DEFECTIVE OR UNAUTHORIZED WORK** - It is the intent of the specifications that only first-class work, materials and workmanship will be acceptable. All work which is defective in its construction or deficient in any of the requirements of the specifications shall be remedied, or removed and replaced by the Contractor in an acceptable manner, and no compensation will be allowed for such correction. Any work done beyond the lines shown on the plans or established by the General Manager, or any extra work done without written authority will be considered as unauthorized and will not be paid for. Upon failure on the part of the Contractor to comply forthwith with any order of the General Manager made under the provisions of this paragraph, the General Manager shall have authority to cause defective work to be remedied or removed and replaced, and unauthorized work to be removed, and to deduct the costs thereof from any moneys due or to become due the Contractor. If the work is found to be in compliance with these specifications, the General Manager will furnish the Contractor with a certificate to that effect.

**V-Q. SUPERVISION** - All manufactured products, materials and appliances used and installed and all details of the work shall at all times be subject to the supervision, test and approval of the General Manager or his authorized representatives. The General Manager or his authorized representatives shall have access to the work at all times during construction, and shall be furnished with every reasonable facility for securing full knowledge with regard to the progress, workmanship and character of the materials used or employed in the work.

Whenever the Contractor varies the period during which work is carried on each day, he shall give adequate notice to the General Manager so that proper inspection may be provided. Any work done in the absence of the General Manager or the General Manager's agent will be subject to rejection. The inspection of the work shall not relieve the Contractor of any of his obligations to fulfill the contract as prescribed. Defective work shall be made good, and unsuitable materials may be rejected, notwithstanding the fact that such defective work and unsuitable materials have previously been accepted or estimated for payment.

The Contractor shall prosecute work on any State highway or with any railroad right-of-way only in the presence of an inspector representing the State Division of Highways or the railroad company, and any work done in the absence of such inspectors will be subject to rejection. The Contractor shall make the appropriate notification according to the instructions given on the State Encroachment Permit or railroad permit for all inspections, and shall post all bonds and certificates required by the permit. The permit shall be acquired by the Contractor at the Contractor's expense. The Contractor shall pay for all testing and inspections required by a State Encroachment Permit or railroad permit.

**V-R. QUALITY OF MATERIAL** - Materials shall be new, and of specified kind and quality, and fully equal to samples when samples are required. When the quality or kind of material or articles shown required under the contract is not particularly specified, the Contractor shall estimate that the Morongo Basin Transit Authority will require articles and materials representing the best of their class or kind or at least equal to the class or quality of similar articles or materials when specified. Materials shall be furnished in such quantities and kinds and at such times as to ensure uninterrupted progress for the work. They shall be stored properly and protected as required. The Contractor shall be entirely responsible for damage or loss by weather or any other cause.

**V-S. DEFECTIVE MATERIALS** - All materials not conforming to the requirements of these specifications shall be considered as defective, and all such materials shall be removed immediately from the site of the work unless otherwise permitted by the General Manager. Upon failure on the part of the Contractor to comply with any order by the General Manager made under the provisions of this article, the General Manager shall have the authority to remove and replace defective material and to deduct the cost of removal and replacement from any moneys due or to become due to the Contractor.

**V-T. SOUND AND VIBRATION CONTROL REQUIREMENTS** - The Contractor shall comply with all local sound control and noise level rules, regulations and ordinances. No internal combustion engine shall operate on the project without a muffler of the type recommended by the manufacturer. Should any muffler or other control device sustain damage, the Contractor shall promptly remove the equipment and shall not return said equipment to the job until the device is repaired or replaced. Said noise and vibration level requirements shall apply to all equipment on the job or related to the job, including, but not limited to truck, transit mixers or transit equipment that may or may not be owned by the Contractor.

**V-U. AIR POLLUTION CONTROL** - Contractor shall comply with all air pollution control rules, regulations, ordinances and statutes. All containers of paint, thinner, during compound, solvent or liquid asphalt shall be labeled to indicate the contents, fully complying with the applicable material requirements.

**V-V. FINAL CLEANING UP** - Upon completion of the project and before making application to the General Manager for acceptance of the work, the Contractor shall clean all the streets and ground occupied by him in connection with the project, of all rubbish, debris, excess material, temporary structures and equipment, leaving the entire site of the work in a neat and presentable condition.

## **SPECIAL PROVISIONS (cont.)**

### **Sub - Section 2. Specific Project Provisions**

MORONGO BASIN TRANSIT AUTHORITY PROJECT: **Bus Stop and Shelter**

**A. THE REQUIREMENTS:** All work embraced herein shall be accomplished in accordance with the applicable portions of the "Standard Specifications for Public Works Construction," the latest edition, and all subsequent supplements herein referred to as "Standard Specifications," except as modified by these Special Provisions and the Project Plans.

In addition to the above, the Contractor shall comply with the requirements of the following:

- (a) Notice Inviting Sealed Bids
- (b) Instructions to Bidders
- (c) Proposal
- (d) Bid Bond
- (e) Information Required of Bidders
- (f) Faithful Performance Bond
- (g) Labor and Material Bond
- (h) Contract Agreement

**B. DEFINITION OF TERMS:** Wherever in the "Standard Specifications" terms are used, they shall be understood to mean and refer to the following:

Agency & Owner - Morongo Basin Transit Authority

Board - Board of Directors, Morongo Basin Transit Authority

General Manager - The General Manager of the Morongo Basin Transit Authority

Engineer - The engineer, acting either directly or through the properly authorized agents, such agents acting within the scope of the particular duties entrusted to them.

Notice to contractors - Notice Inviting Sealed Bids

**C. PROJECT PLANS:** The location of the work, its general nature, extent, form and detail of the various features are listed as a part of these specifications.

**D. SCOPE OF WORK:** Provide necessary labor, equipment and materials to construct concrete curb and gutter, bus shelter pad, sidewalk, install MBTA furnished bus shelters, and associated work at SR 62 and Elk Trail, as specified on the drawings, and in these specifications and special provisions, and as directed by the General Manager.

**E. NOTICE TO PROCEED:** Upon award of this contract and signing the contract documents, the Morongo Basin Transit Authority shall issue the Contractor a Notice to Proceed.

The work on this project shall commence within 10 calendar days of the Notice to Proceed and be completed within **30** working days. **Working days will be counted from the date of the Notice to Proceed.** Working days are defined as any day that Morongo Basin Transit Authority offices are open for business.

The Morongo Basin Transit Authority will not authorize any work to be done under this specifications before the contract agreement has been fully executed; and any work that is done by the contractor in advance of such time shall be considered as being done at his own risk and responsibility, and as a

consequence will be subject to rejection by not having been done in the presence of an Engineer or Inspector as provided in Section 2-10 of the Standard Specifications.

In the event that the General Manager shall be of the opinion that the work is being inadequately or improperly executed in any respect, he/she may demand that the Contractor improve or change the execution of the work in such manner as to assure proper and timely completion.

**F. UTILITIES:** It is anticipated that these existing utilities will not interfere with the Contractor's construction operations. However, the Contractor shall exercise due care to ensure that these utility facilities are not damaged during his operations. When in doubt, the Contractor shall contact the utility concerned before proceeding further.

**G. NOTIFICATION:** The Contractor shall give written and reasonable notice to occupants or owners of property adjacent to the construction site at least forty-eight (48) hours prior to the beginning of construction in their respective areas. The notification shall include the date and time of street closures, parking and traffic access information and requirements, and precautionary information regarding the work to be done. A copy of all notifications shall be submitted to the General Manager for approval.

At least four (4) working days in advance of street closures, all emergency services, public transportation services, garbage collections services, and school bus services shall be notified by the Contractor in writing of the locations, time and date of the closure. In case of schedule changes, the emergency services, etc., shall be notified by telephone at least two (2) days in advance of the street closure.

**H. ACCESS TO DRIVEWAYS:** The Contractor shall notify in writing residents of property adjoining the location of the work at least forty-eight (48) hours before the start of construction on that street. The Contractor is responsible for posting "temporary no-parking" signs at least forty-eight (48) hours before using the parking lane for construction purposes. In the case of work requiring excavation of the roadway which may interfere with the use by residents or businesses of their driveways, suitable provisions shall be made by the Contractor at such time as the exigencies of construction may demand a temporary blocking of said driveways. Efforts shall be made by the Contractor to minimize the duration of said blocking and to notify the residents of this need well in advance. Further, the Contractor shall provide access to each residential or commercial establishment each evening.

**I. STREET CLOSURES:** No closure of any street shall be allowed unless prior written permission is obtained from the General Manager. If permission to close a street is granted then the Contractor is required to notify in writing at least four (4) working days in advance, all emergency services, public transportation services, garbage collection services, and school bus services of the location, time and date of the closure.

**J. CONFERENCE:** The Contractor shall arrange a pre-construction meeting with the General Manager, which shall be held a minimum of five (5) working days prior to commencement of any work. The Contractor shall have his equipment available for inspection by the General Manager at the time of the pre-construction meeting.

**K. PUBLIC CONVENIENCE AND SAFETY:**

a) Attention is directed to Section 7-10 of the Standard Specifications and the Manual of Warning Signs, Lights and Devices for Use in Performing Work Upon Highways, published by the California Department of Transportation.

Full compensation for conforming to the requirements of Section 7-10 of the Standard Specifications, the above referenced Caltrans Manual and these Special Provisions not otherwise provided for, shall be considered as included in the prices paid for the various contract items of work and no additional compensation will be allowed therefore.

b) **WARNING AND PROTECTION DEVICES:** The Contractor will be responsible for providing, placing and maintaining approved signs, barricades, pedestals, flashers, delineators, fences, barriers and

flagmen where needed, and other necessary facilities in the vicinity of the construction area and where any dangerous conditions may be encountered as a result thereof, for the protection of the motoring public. The Contractor will not be allowed to proceed with the work until such time that a sufficient number of these protection devices have been delivered to the project site. Where parked vehicles are likely to interfere with the proposed work, the Contractor will supply and post at no less than 200-foot intervals on each side of the street "Temporary No Parking" signs twenty-four (24) hours before the start of construction and to report the time of posting to the Police Department for the purpose of establishing "Tow Away" provisions. The Contractor shall be responsible for the removal of the temporary signs upon the completion of the work.

Should the Contractor appear neglectful or negligent in furnishing warning and protection devices as outlined above, the General Manager may direct attention to the existence of a hazard and the necessity of additional or different measures which shall be furnished and installed by the Contractor at his own expense, free of any cost to the Morongo Basin Transit Authority. Should the Contractor refuse or fail to act in a timely manner to correct a hazardous condition, the General Manager may direct Morongo Basin Transit Authority forces to provide the necessary protective and warning devices as deemed appropriate by the General Manager.

The cost accrued by the Morongo Basin Transit Authority in connection therewith will be deducted from the Contractor's contract payment. Any action or inaction on the part of the Morongo Basin Transit Authority in directing attention to the inadequacy of warning and protective measures or in providing additional protective and warning devices shall not relieve the Contractor from responsibility for public safety or abrogate his obligation to furnish and pay for these devices.

The Contractor shall submit his work schedule and traffic control plans to the General Manager for approval at the pre-construction conference. This schedule shall allow residents, on the streets to be improved, ample "on street" parking within an 800-foot distance from their homes.

**L. SANITARY CONVENIENCE:** Necessary sanitary facilities for the use of workman on the job shall be provided and maintained in an approved manner by the Contractor, properly secluded from public observation and in compliance with health ordinances and laws, and their use shall be strictly enforced by the Contractor.

**M. CONSTRUCTION YARD:** It shall be the Contractor's responsibility to locate any storage sites for materials and equipment needed and such sites either located on public or private property must be approved in advance by the General Manager.

When storage sites are to be on located upon private property, the Contractor shall be required to submit to the General Manager, written approval from the record owner authorizing the use of the property by the Contractor.

**N. CONSTRUCTION STAKING:** Existing survey monuments shall not be disturbed unless required by the construction of the proposed improvements. The Contractor shall be required to provide any and all necessary construction survey staking required in constructing the project. Full compensation for performing any needed construction survey staking, not otherwise provided for, shall be considered as included in the prices paid for the various contract items of work and no additional compensation will be allowed therefore.

**O. CONSTRUCTION METHODS:**

**General Requirements:**

- (a) Utilities--The Contractor shall contact the affected utility companies for information regarding identification, location, and depth of underground utilities.
- (b) Preservation of Property--Existing improvements in areas adjoining the property whereon

demolition and removal is being performed shall be protected from injury or damage resulting from operations of the Contractor and the Contractor shall be responsible for such damage. In like manner any building, structure, tree, shrub, landscaping, or other item designated for preservation on the property where demolition and removal is being performed shall be similarly protected and preserved.

(c) Dust Control--The Contractor shall provide such dust laying equipment and methods as may be required to protect adjacent property from annoyance or damage from dust caused by his operations, and failure to control such dust shall be cause for the Engineer to stop the work until said dust is controlled, and the Contractor shall have no recourse to collect from the Morongo Basin Transit Authority for any loss of time or expense sustained by him due to such suspension of work.

(d) Selected Materials--Existing materials excavated within the project limits that meet the specifications for trench backfill, topsoil, or other selected materials may be used to fulfill all or a portion of the requirements for such materials. No additional compensation will be allowed for excavation, stockpiling, overhaul, or placing selected materials encountered in the excavation.

(e) Surplus Materials--The Contractor shall furnish written consent from the owner of the property where it is intended to dispose of the surplus material. Surplus excavation shall become the property of the Contractor.

(f) Furnishing and Applying Water--Furnishing and applying water shall be considered as included in the bid price paid for the various contract items of work requiring such water and no additional compensation will be made therefore.

(g) Compaction Testing: – The expense of the initial testing shall be borne by MBTA. The expense of any re-testing required by MBTA, if the initial compaction does not meet the required specifications shall be borne by the Contractor. All other material testing shall be borne by the Contractor.

(h) Construction Methods--The improvement work shall consist of providing necessary labor, equipment and materials to construct concrete curb and bus turnout, bus shelter pad, sidewalk, install MBTA furnished bus shelters, and associated work at SR 62 and Airway Avenue, as specified on the drawings, and in these specifications and special provisions, and as directed by the General Manager.

(i) Measurement and Payment--The Cost of all work as described above in (a) through (h) shall be included in the contract unit prices bid for the various items of work requiring such work, and no additional compensation will be allowed.

**Bid Item No. 1 – Sawcut and Remove Existing AC Pavement:**

(a) General – All work shall conform to Section 300 of the Standard Specifications. The work shall consist of removal of existing pavement to the limits shown on the project plans. The work shall also include all necessary sawcutting, disposal of materials; reinstate disturbed surrounding areas to their original conditions, and all other work necessary to complete the removal of existing AC pavement, as shown on the project plans.

(b) Measurement and Payment— The cost of all work described above and also including all costs of materials, labor, tools, equipment, and incidentals, and for doing all the work involved, complete in place, shall be included in the contract unit price bid for Bid Item No. 1 – Sawcut and Remove Existing AC Pavement, and no additional compensation will be allowed.

**Bid Item No. 2 – Sawcut and Remove Existing AC Curb:**

(a) General – All work shall conform to Section 300 of the Standard Specifications. The work shall consist of removal of existing AC curb to the limits shown on the project plans. The work shall also include all necessary sawcutting, disposal of materials; reinstate disturbed surrounding areas to their original

conditions, and all other work necessary to complete the removal of existing AC curb, as shown on the project plans.

(b) Measurement and Payment— The cost of all work described above and also including all costs of materials, labor, tools, equipment, and incidentals, and for doing all the work involved, complete in place, shall be included in the contract unit price bid for Bid Item No. 2 – Sawcut and Remove Existing AC Curb, and no additional compensation will be allowed.

**Bid Item No. 3 – Sawcut and Remove Existing Concrete Curb Ramp and Spandrel:**

(b) General – All work shall conform to Section 300 of the Standard Specifications. The work shall consist of removal of existing concrete curb ramp and spandrel to the limits shown on the project plans. The work shall also include all necessary sawcutting, disposal of materials; reinstate disturbed surrounding areas to their original conditions, and all other work necessary to complete the removal of existing concrete curb ramp and spandrel, as shown on the project plans.

(b) Measurement and Payment— The cost of all work described above and also including all costs of materials, labor, tools, equipment, and incidentals, and for doing all the work involved, complete in place, shall be included in the contract unit price bid for Bid Item No. 3 – Sawcut and Remove Existing Concrete Curb Ramp and Spandrel, and no additional compensation will be allowed.

**Bid Item No. 4 – Remove Existing Bus Shelter, Bench, Trash Receptacle, and Bus Stop Sign and Post:**

(a) General – All work shall conform to manufacturer's recommendations and MBTA requirements. The work shall consist of removal of concrete anchors to existing sidewalk; remove existing bus shelter, bench, trash receptacle, and bus stop sign and post; loading, deliver, and unloading from job site to MBTA yard at Joshua Tree. The work shall also include all necessary sawcutting, excavation, backfill, disposal of materials, concrete sidewalk repair, and reinstate disturbed surrounding areas to their original conditions, and all other work necessary to complete the removal of existing bus shelter, bench, and trash receptacle.

(b) Measurement and Payment – The cost of all work described above and also including all costs of materials, labor, tools, equipment, and incidentals, and for doing all the work involved, complete in place, shall be included in the contract lump sum price bid for Bid Item No. 4 – Remove Existing Bus Shelter, Bench, Trash Receptacle, and bus stop sign and post, and no additional compensation will be allowed.

**Bid Item No. 5 – Grading:**

(a) General – All work shall conform to Section 300 of the Standard Specifications. The work shall consist of clearing and grubbing, import borrow material, export surplus material, excavation, embankment, removing necessary shrubs, fences, posts, and stakes, protecting existing improvements, erosion control, controlling nuisance water, sweeping, and watering.

When import is required, contractor shall provide location of borrow site, obtain MBTA approval of the material prior to import, and obtain MBTA approval of a haul route.

When export is required, contractor shall coordinate with MBTA for location of a disposal site for all excavated material. All excavated material shall become property of the contractor unless notified otherwise.

Contractor shall provide full access to properties adjacent to project site with the minimum amount of interruption to access as possible.

(b) Measurement and Payment – The Cost of all work described above and also including all costs of



materials, labor, tools, equipment, and incidentals, and for doing all the work involved, complete in place, not otherwise paid for by other bid items, shall be included in the contract lump sum price bid for Bid Item No. 5 – Grading, and no additional compensation will be allowed.

**Bid Item No. 6 – Concrete Curb Ramp and Spandrel:**

(a) General -- All work shall conform to Sections 300, 301, and 302 Standard Specifications, and Caltrans Standard Drawings. The work shall consist of fine grading, preparation of new subgrade by scarifying and re-compacting, set and remove forms, placing steel reinforcement, placing concrete, installing joints, and all other work necessary to complete the construction of concrete curb ramp and spandrel, including retaining curb.

(b) Measurement and Payment -- The cost of all work described above and also including all costs of materials, labor, tools, equipment, and incidentals, and for doing all the work involved, complete in place, shall be included in the contract unit price bid for Bid Item No. 6 –Concrete Curb Ramp and Spandrel, and no additional compensation will be allowed.

**Bid Item No. 7 – 6” Concrete Curb and Gutter:**

(a) General -- All work shall conform to Caltrans Standard Specifications, and the Caltrans Standard Plans. The work shall consist of preparation of new subgrade by scarifying and re-compacting, set and remove forms, placing concrete, installing joints, and all other work necessary to complete the construction of concrete curb and gutter.

(b) Measurement and Payment -- The cost of all work described above and also including all costs of materials, labor, tools, equipment, and incidentals, and for doing all the work involved, complete in place, shall be included in the contract unit price bid for Bid Item No. 7 – 6” Concrete Curb and Gutter, and no additional compensation will be allowed.

**Bid Item No. 8 – 4” Thick Concrete Sidewalk:**

(a) General – All work shall conform to Sections 300, 301, and 303 of the Standard Specifications, and San Bernardino County Standard Drawings. The work shall consist of preparation of new subgrade by scarifying and re-compacting, set and remove forms, placing concrete, installing joints, and all other work necessary to complete the construction of concrete sidewalk.

(b) Measurement and Payment – The cost of all work described above and also including all costs of materials, labor, tools, equipment, and incidentals, and for doing all the work involved, complete in place, shall be included in the contract unit price bid for Bid Item No. 8 – 4” Thick Concrete Sidewalk, and no additional compensation will be allowed.

**Bid Item No. 9 – 6” Thick Concrete Bus Shelter Pad:**

(a) General -- All work shall conform to Sections 300, 301, and 303 of the Standard Specifications. The work shall consist of fine grading, preparation of new subgrade by scarifying and re-compacting, set and remove forms, placing steel reinforcement, placing concrete, installing joints, and all other work necessary to complete the construction of concrete bus shelter pad..

(b) Measurement and Payment -- The cost of all work described above and also including all costs of materials, labor, tools, equipment, and incidentals, and for doing all the work involved, complete in place, shall be included in the contract unit price bid for Bid Item No. 9 – 6” Thick Concrete Bus Shelter Pad, and no additional compensation will be allowed.

**Bid Item No. 10 – AC Backfill:**

(a) General – All Work shall conform to Caltrans Standard Specifications. The work shall consist of preparation of new subgrade by scarifying and re-compacting, placing asphalt concrete, compaction, removal of loose and broken asphalt concrete pavement and foreign materials, and all other work necessary to complete the asphalt concrete backfill.

(b) Material – Asphalt concrete shall conform to Caltrans Standard Specifications designation PG 70-10, and ½” maximum medium gradation, or other class and grade as approved by the Engineer.

(c) Tack Coat – A tack coat shall be furnished by the contractor and applied to all vertical and horizontal joints, between pavement layers, on concrete surfaces, and on existing pavement to be resurfaced, prior to placing the asphalt concrete, in accordance with Section 39-4 of the Caltrans Standard Specifications.

(d) Measurement and Payment – The Cost of all work described above and also including all costs of materials, labor, tools, equipment, and incidentals, and for doing all the work involved, complete in place, shall be included in the contract unit price bid for Bid Item No. 10 – AC Backfill, and no additional compensation will be allowed. No separate measurement and payment will be made for asphalt tack coat

**Bid Item No. 11 – Transport, Assemble, and Install MBTA Furnished Bus Shelter, Bench, and Trash Receptacle:**

(c) General – All work shall conform to manufacturer’s recommendations and MBTA requirements. The work shall consist of loading, deliver, and unloading bus shelter, bench, and trash receptacle from MBTA yard at Joshua Tree to job site; assemble and install bus shelter, bench, trash receptacle, including anchor to concrete pad, and all other work necessary to complete the installation of bus shelter, bench, and trash receptacle.

(d) Measurement and Payment – The cost of all work described above and also including all costs of materials, labor, tools, equipment, and incidentals, and for doing all the work involved, complete in place, shall be included in the contract unit price bid for Bid Item No. 11 – Transport, Assemble, and Install MBTA Furnished Bus Shelter, Bench, and Trash Receptacle, and no additional compensation will be allowed.

**Bid Item No. 12 – Coordination with Caltrans, Obtain Caltrans Double Permit, Comply With Permit Provisions, and Traffic Control:**

(a) General – All work shall conform to the Caltrans Traffic Control Plan and Caltrans requirements. The work shall consist of coordination with Caltrans for a pre-construction meeting, inspection, and all other activities throughout the construction period; obtain and pay for a Caltrans double permit at Caltrans District 8 Permit Division (permit fee will be reimbursed by MBTA); comply with all permit provisions including preparation, obtain approval, and implementation of a Water Pollution Control Program (WPCP); and furnish, install, maintain, relocate, and remove traffic control devices, including flashing arrow and flashing beacon, throughout the construction period.

(b) Measurement and Payment – The cost of all work described above and also including all costs of materials, labor, tools, equipment, and incidentals, and for doing all the work involved, complete in place, shall be included in the contract lump sum price bid for Bid Item No. 12 – Coordination with Caltrans, Obtain Caltrans Double Permit, Comply With Permit Provisions, and Traffic Control, and no additional compensation will be allowed.

**Bid Item No. 13 – Relocate Existing MBTA Bus Stop Sign and Post:**

(a) General – All work shall conform to Caltrans Standard Specifications and BMTA requirements. The work shall consist of removal of existing MBTA bus stop sign and post from current location and installation at new location, and shall include all necessary sawcutting, excavation, footing, backfill, and

compaction, as shown on the project plans.

(b) Measurement and Payment – The cost of all work described above and also including all costs of materials, labor, tools, equipment, and incidentals, and for doing all the work involved, complete in place, shall be included in the contract unit price bid for Bid Item No. 13 – Relocate Existing MBTA Bus Stop Sign and Post, and no additional compensation will be allowed.

**Bid Item No. 14 – Relocate Existing Speed Sign and Post:**

(a) General – All work shall conform to Caltrans Standard Plans and Specifications. The work shall consist of removal of existing traffic sign and post from current location and installation at new location, and shall include excavation, remove and reconstruct concrete footings, backfill, and compaction, as shown on the project plans.

(b) Measurement and Payment – The cost of all work described above and also including all costs of materials, labor, tools, equipment, and incidentals, and for doing all the work involved, complete in place, shall be included in the contract unit price bid for Bid Item No. 14 – Relocate Existing Speed Sign and Post, and no additional compensation will be allowed.

**Bid Item Nos. 15 –Traffic Sign and Post:**

(a) General – All work shall conform to Caltrans Standard Specifications and Standard Plans. The work shall consist of furnishing and installing new traffic sign and post, and shall include excavation, backfill, compaction, and reinstate disturbed surrounding areas to their original conditions.

(b) Measurement and Payment – The cost of all work described above and also including all costs of materials, labor, tools, equipment, and incidentals, and for doing all the work involved, complete in place, shall be included in the contract unit price bid for Bid Item No. 15 – Traffic Sign and Post, and no additional compensation will be allowed.

**Bid Item No. 16 – Construction Staking:**

(a) General – All work shall conform to Caltrans Standard Specifications and the project plans. The work shall consist of providing construction surveying and staking, and all other work necessary to perform the staking. Cut sheets and field notes shall be submitted to the Engineer.

(b) Measurement and Payment – The cost of all work described above and also including all costs of materials, labor, tools, equipment, and incidentals, and for doing all the work involved, complete in place, shall be included in the contract lump sum price bid for Bid Item No. 16 – Construction Staking, and no additional compensation will be allowed.

**Bid Item No. 17 – Paint New Curb With Red Paint Per Caltrans Standard Specifications Section 84-2:**

(a) General – All work shall conform to Caltrans Standard Specifications. The work shall consist of furnish and install paint, as shown on the project plans.

(b) Measurement and Payment – The cost of all work described above and also including all costs of materials, labor, tools, equipment, and incidentals, and for doing all the work involved, complete in place, shall be included in the contract unit price bid for Bid Item No. 17 – Paint New Curb With Red Paint Per Caltrans Standard Specifications Section 84-2, and no additional compensation will be allowed.

# PROPOSAL

TO THE BOARD OF DIRECTORS OF THE MORONGO BASIN TRANSIT AUTHORITY

The undersigned, as bidder, declares that: (1) this proposal is made without collusion with any other person, firm or corporation, and that the only persons or parties interested as principals are those named herein; (2) bidder has carefully examined the project plans, specifications, instructions to bidders, proposal, notice to contractors and all other information furnished therefore and the site of the proposed work; (3) bidder has investigated and is satisfied as to the conditions to be encountered, the character, quality and quantities of work to be performed and materials to be furnished. Furthermore, bidder agrees that submission of this proposal shall be conclusive evidence that such examination and investigation have been made and agrees, in the event this contract be awarded to bidder, to enter into a contract with the Board of Directors of the Morongo Basin Transit Authority, to perform said proposed work in accordance with the plans, if any, and the terms of the specifications, in the time and manner therein prescribed, and to furnish or provide all materials, labor, tools, equipment, apparatus and other means necessary so to do, except such thereof as may otherwise be furnished or provided under the terms of said specifications, for the following stated unit prices or lump sum price as submitted on the Schedule attached hereto.

The bidder shall submit as part of this proposal a completed copy of the Contractor's Industrial Safety Record.

Accompanying this proposal is \_\_\_\_\_ (Insert "\$\_\_\_\_\_cash", "Cashier's Check", "certified check", or "Bid Bond", as the case may be) in the amount equal to at least ten percent (10%) of the total aggregate bid price hereof based on the quantities shown and the unit prices quoted.

The undersigned further agrees that should he be awarded the contract on the basis hereof and thereafter, defaults in executing the required contract, with necessary bonds and documents, within fifteen (15) calendar days, after having received notice that the contract has been awarded and is ready for signature, the proceeds of the security accompanying his bid shall become the property of the Morongo Basin Transit Authority and this proposal and the acceptance thereof may be considered null and void.

The undersigned is licensed in accordance with an act providing for the registration of contractors, California

Contractor's License No. \_\_\_\_\_, Class \_\_\_\_\_.

Signature(s) of bidder \_\_\_\_\_

If an individual, so state. If a firm or co-partnership, state the firm name and give the names of all individual co-partners composing the firm. If a corporation, state legal name of corporation, also names of president, secretary, treasurer, and manager thereof. Two notarized officer's signatures and the corporate seal are required for corporations. One signature must be by either the President or Vice-President and the second signature must be by either the secretary or assistant secretary.

By: \_\_\_\_\_  
Title: \_\_\_\_\_

"corporate seal"

By: \_\_\_\_\_  
Title: \_\_\_\_\_

Morongo Basin Transit Authority – Bus Stop and Shelter (IFB 19-01)

By: \_\_\_\_\_  
Title:

By: \_\_\_\_\_

Legal Business Name:

\_\_\_\_\_

Address \_\_\_\_\_

Telephone \_\_\_\_\_

Proposals which do not show the number and date of the Bidder's License under the provisions of Chapter 9 of Division 3 of the Business & Professional Code may be rejected.

To be submitted with each bid:

Project Identification No. \_\_\_\_\_ to contract for \_\_\_\_\_

Bid Date \_\_\_\_\_

This information must include all construction work undertaken in the State of California by the bidder and partnership joint venture or corporation that any principal of the bidder participated in as a principal or owner for the last five calendar years and the current calendar year prior to the date of bid submittal. Separate information shall be submitted for each particular partnership, joint venture, corporate or individual bidder. The bidder may attach any additional information or explanation of data which he would like to be taken into consideration in evaluating the safety record. An explanation must be attached of the circumstances surrounding any and all fatalities.

# PROPOSAL

## PAY ITEMS AND BID PRICE SCHEDULE

To the Board of Directors of the Morongo Basin Transit Authority:

In compliance with the Notice Inviting Sealed Bids, the undersigned hereby agrees to enter into a contract to furnish all labor, materials, equipment and supplies for **Bus Stop and Shelter** in accordance with the specifications and plans in the Contract Documents which are on file in the office of the General Manager of the Morongo Basin Transit Authority to the satisfaction and under the direction of the General Manager at the following prices:

Item	Description	Qty.	Unit	Unit Price	Extended Amount
1	Sawcut and Remove Existing AC Pavement (See page C-14 for description)	304	SF	\$ _____	\$ _____
2	Sawcut and Remove Existing AC Curb (See page C-14 for description)	55	LF	\$ _____	\$ _____
3	Sawcut and Remove Existing Concrete Curb Ramp and Spandrel (See page C-15 for description)	2	EA	\$ _____	\$ _____
4	Remove Existing Bus Shelter, Bench, Trash Receptacle, and bus stop sign and post (See page C-15 for description)	1	LS	\$ _____	\$ _____
5	Grading (See page C-15 for description)	1	LS	\$ _____	\$ _____
6	Concrete Curb Ramp and Spandrel (See page C-16 for description)	2	EA	\$ _____	\$ _____
7	6" Concrete Curb and Gutter (See page C-16 for description)	55	LF	\$ _____	\$ _____
8	4" Thick Concrete Sidewalk (See page C-16 for description)	326	SF	\$ _____	\$ _____
9	6" Thick Concrete Bus Shelter Pad (See page C-16 for description)	60	SF	\$ _____	\$ _____
10	AC Backfill (See page C-16 for description)	304	SF	\$ _____	\$ _____
11	Transport, Assemble and Install MBTA Furnished Bus Shelter, Bench, and Trash Receptacle (See page C-17 for description)	1	EA	\$ _____	\$ _____

Morongo Basin Transit Authority – Bus Stop and Shelter (IFB 19-01)

Item	Description	Qty.	Unit	Unit Price	Extended Amount
12	Coordination with Caltrans, Obtain Caltrans Double Permit, Comply With Permit Provisions, and Traffic Control (See page C-17 for description)	1	LS	\$ _____	\$ _____
13	Relocate Existing MBTA Bus Stop Sign and Post (See page C-17 for description)	1	EA	\$ _____	\$ _____
14	Relocate Existing Speed Sign and Post (See page C-18 for description)	1	EA	\$ _____	\$ _____
15	Traffic Sign and Post (See page C-18 for description)	4	EA	\$ _____	\$ _____
16	Construction Staking (See page C-18 for description)	1	LS	\$ _____	\$ _____
17	Paint New Curb With Red Paint Per Caltrans Standard Specifications Section 84-2 (See page C-18 for description)	40	LF	\$ _____	\$ _____

**TOTAL BID FOR ITEMS 1 TO 17:** \$ \_\_\_\_\_  
(Figure)

**TOTAL BID FOR ITEMS 1 TO 17:** \_\_\_\_\_  
(Words)

Bidder acknowledges receipt of the following Addendum:

Addendum No. \_\_\_\_\_ Date: \_\_\_\_\_

Addendum No. \_\_\_\_\_ Date: \_\_\_\_\_

Addendum No. \_\_\_\_\_ Date: \_\_\_\_\_

Attached to this Proposal is cash, a cashiers check, or certified check in favor of the Morongo Basin Transit Authority, in an amount equal to at least ten percent (10%) of the total bid, or a bid bond for said amount in the form furnished by the Morongo Basin Transit Authority, with the understanding that said security shall be held by the Morongo Basin Transit Authority until the agreement for doing the work has been entered into, that said security shall be forfeited to the Morongo Basin Transit Authority as liquidated damages should the undersigned fail to enter into a contract and furnish the required bonds and insurance within the time specified in the Contract Documents, if awarded the contract, and the undersigned agrees that in the event of such failure, the actual amount of damages to the Morongo Basin

Morongo Basin Transit Authority – Bus Stop and Shelter (IFB 19-01)

Transit Authority would be impractical and extremely difficult to determine.

Dated: \_\_\_\_\_

FIRM NAME \_\_\_\_\_

SIGNATURE \_\_\_\_\_

Title \_\_\_\_\_

SIGNATURE \_\_\_\_\_

Title \_\_\_\_\_

SIGNATURE \_\_\_\_\_

Title \_\_\_\_\_

If a partnership, names of partners. If a corporation, names of President and Vice President, and the Secretary or Assistant Secretary.

NAME & ADDRESS:

\_\_\_\_\_

TELEPHONE \_\_\_\_\_

\_\_\_\_\_

\_\_\_\_\_

CONTRACTOR'S LICENSE NO. \_\_\_\_\_

\_\_\_\_\_

Please indicate whether proprietorship, corporation, or partnership and any use of fictitious business name:

Corporation \_\_\_\_ Partnership \_\_\_\_ Proprietorship \_\_\_\_

Fictitious Name \_\_\_\_\_



## CONTRACTOR'S INDUSTRIAL SAFETY RECORD

Record Last Five (5) Full Years

Year	2015	2016	2017	2018	2019	Total
No. of contracts						
Total amount of contracts (Thousands of dollars)						
No. of lost work days*						
No. of fatalities*						
No. of lost workday cases involving permanent transfer to another job or termination of employee*						

\*The information required for these items is the same as required for columns 3 to 6, Code 10, Occupational Injuries, Summary--Occupational Injuries and Illnesses, OSHA No. 102.

The above information was compiled from the records that are available to me at this time and I declare under penalty of perjury that the information is true and accurate within the limitations of those records.

\_\_\_\_\_  
Name of Bidder (print)

\_\_\_\_\_  
Signature

\_\_\_\_\_  
Address

\_\_\_\_\_  
State Contractor's Lic. No. & Classification

\_\_\_\_\_  
City

\_\_\_\_\_  
Zip Code

\_\_\_\_\_  
Telephone

*(THE BIDDER'S EXECUTION ON THE SIGNATURE PORTION OF THIS PROPOSAL SHALL ALSO CONSTITUTE AN ENDORSEMENT AND EXECUTION OF THOSE CERTIFICATIONS WHICH ARE A PART OF THIS PROPOSAL)*

## **EQUAL EMPLOYMENT OPPORTUNITY CERTIFICATION**

The bidder \_\_\_\_\_, proposed subcontractor \_\_\_\_\_, hereby certifies that he has \_\_\_\_\_, has not \_\_\_\_\_, participated in a previous contract or subcontract subject to the equal opportunity clause, as required by Executive Orders 10925, 11114, or 11246, and that, where required, he has \_\_\_\_\_, has not \_\_\_\_\_, filed with the Joint Reporting Committee, the Director of the Office of Federal Contract Compliance, a Federal Government contracting or administering agency, or the former President's Committee on Equal Employment Opportunity, all reports due under the applicable filing requirements.

**Note:** The above certification is required by the Equal Employment Opportunity Regulations of the Secretary of Labor (41 CFR 60-1.7(b)(1)), and must be submitted by bidders and proposed subcontractors only in connection with contracts and subcontracts which are subject to the equal opportunity clause. Contracts and subcontracts which are exempt from the equal opportunity clause are set forth in 41 CFR 60-1.5. (Generally only contracts or subcontracts or \$10,000.00 or under are exempt.)

Currently, Standard Form 100 (EEO-1) is the only report required by the Executive Orders or their implementing regulations.

Proposed prime contractors and subcontractors who have participated in a previous contract or subcontract subject to the Executive Orders and have not filed the required reports should note that 41 CFR 60-1.7(b)(1) prevents the award of contracts and subcontracts unless such contractor submits a report covering the delinquent period or such other period specified by the Federal Highway Administration or by the Director, Office of Federal Contract Compliance, U.S. Department of Labor.

**This certification for the prime contractor must be submitted at bid time with the bid. Certification for subcontractors, if not submitted at bid time, can be submitted within seven days after bid opening.**



## **NONCOLLUSION AFFIDAVIT**

(Title 23 United States Code Section 112 and  
Contract Code Section 7106)

To the Morongo Basin Transit Authority

In accordance with Title 23 United States Code Section 112 and Public Contract Code 7106 the bidder declares that the bid is not made in the interest of or on behalf of, any undisclosed person, partnership, company, association, organization, or corporation; that the bid is genuine and not collusive or sham; that the bidder has not directly or indirectly induced or solicited any other bidder to put in a false or sham bid, and has not directly or indirectly colluded, conspired, connived, or agreed with any bidder or anyone else to put in a sham bid, or that anyone shall refrain from bidding; that the bidder has not in any manner, directly or indirectly, sought by agreement, communication, or conference with anyone to fix the bid price of the bidder or any other bidder, or to fix any overhead, profit, or cost element of the bid price, or of that of any other bidder, or to secure, any advantage against the public body awarding the contract of anyone interested in the proposed contract; that all statements contained in the bid are true; and, further, that the bidder has not, directly or indirectly, submitted his or her bid price or any breakdown thereof, or the contents thereof, or divulged information or data relative thereto, or paid, and will not pay, any fee to any corporation, partnership, company association, organization, bid depository, or to any member or agent thereof to effectuate a collusive or sham bid.

Note: The above Non-collusion Affidavit is part of the Proposal. Signing this Proposal on the signature portion thereof shall also constitute signature of the Non-collusion Affidavit.

Bidders are cautioned that making a false certification may subject the certifier to criminal prosecution.

## **DEBARMENT AND SUSPENSION CERTIFICATION**

### TITLE 49, CODE OF FEDERAL REGULATIONS, PART 29

The bidder, under penalty of perjury, certifies that, except as noted below, he/she or any other person associated therewith in the capacity of owner, partner, director, officer, manager:

- is not currently under suspension, debarment, voluntary exclusion, or determination of ineligibility by any federal agency;
- has not currently under suspension, debarment, voluntarily excluded or determined ineligible by any federal agency within the past three (3) years;
- does not have a proposed debarment pending; and
- has not been indicted, convicted, or had a civil judgment rendered against it by a court of competent jurisdiction in any matter involving fraud or official misconduct within the past three (3) years.

If there are any exceptions to this certification, insert the exceptions in the following space.

Exceptions will not necessarily result in denial of award, but will be considered in determining bidder responsibility. For any exception noted above, indicate below to whom it applies, initiating agency, and dates of action.

Notes: Providing false information may result in criminal prosecution or administrative sanctions.

The above certification is part of the Proposal. Signing this Proposal on the signature portion thereof shall also constitute signature of this Certification.

# BIDDER'S BOND TO ACCOMPANY PROPOSAL

## MORONGO BASIN TRANSIT AUTHORITY STATE OF CALIFORNIA

KNOWN ALL PERSONS BY THESE PRESENTS:

That we, \_\_\_\_\_ as Principal, and \_\_\_\_\_ as Surety, are held and firmly bound unto the Morongo Basin Transit Authority in the sum of \_\_\_\_\_ (\$\_\_\_\_\_) dollars, to be paid to the said Morongo Basin Transit Authority or its certain attorneys, its successors and assigns; for the payment of which sum, well and truly made, we bind ourselves, our heirs, executors and administrators, successors or assigns, jointly and severally, firmly by these presents.

THE CONDITION OF THIS OBLIGATION IS SUCH

That if the certain proposal of the above bounded \_\_\_\_\_ to \_\_\_\_\_ dated \_\_\_\_\_, 20\_\_\_\_, is accepted by the Morongo Basin Transit Authority, and if the above bounded \_\_\_\_\_ his heirs, executors, administrators, successors and assigns, shall duly enter into and execute a contract for such construction, and shall execute and deliver the two bonds described within fifteen (15) calendar days, from the date of the mailing of a notice to the above bounden \_\_\_\_\_ by and from the said Morongo Basin Transit Authority that said contract is ready for execution, then this obligation shall become null and void; otherwise it shall be and remain in full force and virtue.

IN WITNESS WHEREOF, we hereunto set our hands and seals this \_\_\_\_\_ day of \_\_\_\_\_, 20\_\_\_\_.

\_\_\_\_\_  
Principal

By \_\_\_\_\_  
Title:

"corporate seal"

By \_\_\_\_\_  
Title:

\_\_\_\_\_  
Surety

"corporate seal"

By \_\_\_\_\_  
Attorney-in-Fact

PLEASE ATTACH NOTARY ACKNOWLEDGEMENT (for Bonding Company's Signature Only)

## INFORMATION REQUIRED OF BIDDERS

The bidder is required to supply the following information. Additional sheets may be attached if necessary.

(1) Name: \_\_\_\_\_

(2) Address: \_\_\_\_\_

(3) Telephone: \_\_\_\_\_

(4) Type of firm - Individual, Partnership, or Corporation: \_\_\_\_\_

(5) Corporation organized under the laws of the State of: \_\_\_\_\_

(6) Contractor's license no. and class: \_\_\_\_\_

(7) List the names and addresses of all members of the firm or names and titles of all officers of the corporation:

\_\_\_\_\_

\_\_\_\_\_

\_\_\_\_\_

\_\_\_\_\_

\_\_\_\_\_

(8) Number of years experience as a contractor in construction work: \_\_\_\_\_

(9) List at least three projects completed as of recent date:

<u>Contract Amount</u>	<u>Class of Work</u>	<u>Date Completed</u>	<u>Name &amp; Address of Owner</u>
------------------------	----------------------	-----------------------	------------------------------------

_____	_____	_____	_____
_____	_____	_____	_____
_____	_____	_____	_____
_____	_____	_____	_____
_____	_____	_____	_____

(10) List the name of the person who inspected the site of the proposed work for your firm:

\_\_\_\_\_

(11) NOTE: Upon request of the MBTA, the bidder shall furnish evidence showing a notarized financial statement, financial data, construction experience, or other information.

**PERFORMANCE BOND**

KNOW ALL MEN BY THESE PRESENTS: THAT

WHEREAS, the Morongo Basin Transit Authority, in the County of San Bernardino, State of California, by Council action of \_\_\_\_\_, has awarded to \_\_\_\_\_ hereinafter designated as the "Principal," a contract for construction of the \_\_\_\_\_ together with appurtenances thereto, and

WHEREAS, said Principal is required under the terms of said Contract to furnish a bond for the faithful performance of said Contract.

NOW, THEREFORE, we \_\_\_\_\_ as Principal, and \_\_\_\_\_ as Surety, are held and firmly bound unto the Morongo Basin Transit Authority, hereinafter called the "Contracting Morongo Basin Transit Authority" in the penal sum of one hundred percent (100%) of the amount of \_\_\_\_\_ Dollars (\$\_\_\_\_\_), lawful money of the United States of America, for payment of which sum well and truly to be made, we bind ourselves, our heirs, executors, administrators and successors, jointly and severally, firmly by these presents.

THE CONDITION OF THE OBLIGATION IS SUCH that, if the hereby bounded Principal, his or its heirs, executors, administrators, successors or assigns, shall in all things stand to and abide by and well and truly keep and perform all the undertakings, terms, covenants, conditions and agreements in said Contract and any alteration thereof, made as therein provided all within the time and in the manner therein designated and in all respects according to their true intent and meaning, then this obligation shall become null and void, otherwise it shall be and remain in full force and virtue.

FURTHER, said Surety, for value received, hereby stipulates and agrees that no change, extension of time, alteration or modification of the Contract Documents or of the work to be performed thereunder shall in any way affect its obligation on this bond, and it does hereby waive notice of any such change, extension of time, alteration or modification of the Contract Documents or of work to be performed thereunder.

IN WITNESS WHEREOF, three (3) identical counterparts of this instrument, each of which shall for all purposes be deemed an original thereof, have been duly executed by the Principal and Surety herein named on the \_\_\_\_ day of \_\_\_\_\_, 20\_\_\_\_. The name and corporate seal of each corporate party being hereto affixed and these presents fully signed by its undersigned representative pursuant to authority of its governing body.

\_\_\_\_\_  
Principal  
By \_\_\_\_\_  
Title:

"corporate seal"

By \_\_\_\_\_  
Title:

\_\_\_\_\_  
Surety

"corporate seal"

By \_\_\_\_\_  
Attorney-in-Fact

PLEASE ATTACH NOTARY ACKNOWLEDGEMENT



**PAYMENT BOND**

(BOND FOR LABOR AND MATERIAL)

KNOW ALL MEN BY THESE PRESENTS: THAT

WHEREAS, the Morongo Basin Transit Authority, in the County of San Bernardino, State of California, by Board action of \_\_\_\_\_, has awarded to \_\_\_\_\_ hereinafter designated as the "Principal," a contract for construction of the \_\_\_\_\_ together with appurtenances thereto, and

WHEREAS, said Principal is required to furnish a bond in connection with said contract providing that if said Principal, or any of his or its subcontractors shall fail to pay for any materials, provisions, provender, fuel, or other supplies or equipment used in, upon, or about the performance of the work contracted to be done, or for any work or labor done thereon of any kind, the Surety of this bond will pay the same to the extent hereinafter set forth;

NOW, THEREFORE, we \_\_\_\_\_ as Principal, and \_\_\_\_\_ as Surety, are held and firmly bound unto the Morongo Basin Transit Authority, hereinafter called the contracting Authority, in the penal sum of one hundred percent (100%) of the amount of \_\_\_\_\_ Dollars (\$\_\_\_\_\_), lawful money of the United States of America, for the payment of which sum well and truly to be made, we bind ourselves, our heirs, executors, administrators, successors, jointly and severally, firmly by these presents.

THE CONDITION OF THIS OBLIGATION IS SUCH THAT if said Principal, his or its heirs, executors, administrators, successors, or assigns, shall fail to pay for any materials, provisions, provender, rented or hired teams, implements, or machinery, or other supplies or equipment of any kind used in, upon, for or about the performance of the work contracted to be done, including, but not limited to, that part of water, gas, power, light, heat, oil, gasoline, or telephone service directly applicable to the contract, or for any work or labor thereon of any kind, or for any amounts due under the California Unemployment Insurance Code with respect to such work or labor, or for any amounts required to be deducted, withheld, and paid over to the Employment Development Department from the wages of the employees of said Principal and subcontractors pursuant to Section 13020 of the California Unemployment Insurance Code with respect to such work and labor, and provided that any person, so furnishing said supplies or equipment therefore shall have complied with the provisions of Chapter 7 of Title 15 of Part 4 of Division 3 of the California Civil Code, as amended, or any successor thereto, then said Surety shall pay the same in or to an amount not exceeding the amount hereinabove set forth and also shall pay in case suit is brought upon this bond, such reasonable attorney's fees as shall be fixed by the court.

The bond shall inure to the benefit of any and all persons, companies, and corporations named in California Civil Code Section 3181, as amended, or any successor thereto, so as to give a right of action to them or their assigns in any suit brought upon this bond.

FURTHER, the Surety, for value received, hereby stipulates and agrees that no change, extension of time, alteration, or modifications of the Contract Documents or of the work to be performed thereunder shall in any way affect its obligations of this bond and it does hereby waive notice of such change, extension of time, alteration, or modification of the Contract Documents or of work to be performed thereunder.

Notices, papers and other documents required by Chapter 2 of Title 14 of Part 2 of Code of Civil Procedure, or by any other law, regulation, or requirement of the Contract may be served upon Principal at this address:

---

---

---

and upon Surety at this address:

---

---

---

IN WITNESS WHEREOF, three (3) identical counterparts of this instrument, each of which shall for all purposes be deemed an original thereof, have been duly executed by the Principal and Surety herein named, under penalty of perjury, on the \_\_\_\_\_ day of \_\_\_\_\_, 20\_\_\_\_, the name and corporate seal of each corporate party being hereto affixed and these presents duly signed by its undersigned representative pursuant to authority of its governing body.

\_\_\_\_\_  
Principal

By \_\_\_\_\_  
Title:

"corporate seal"

By \_\_\_\_\_  
Title:

\_\_\_\_\_  
Surety

"corporate seal"

By \_\_\_\_\_  
Attorney-in-Fact

PLEASE ATTACH NOTARY ACKNOWLEDGEMENT

## WORKER'S COMPENSATION CERTIFICATE OF INSURANCE

WHEREAS, the Morongo Basin Transit Authority has required certain insurance to be provided by

---

NOW THEREFORE, the undersigned insurance company does hereby certify that it has issued the policy or policies described below to the following named insureds and that the same are in force at this time.

1. This certificate is issued to: Morongo Basin Transit Authority, 62405 Verbena Road, Joshua Tree, California 92252.
2. The insureds under such policy or policies are: \_\_\_\_\_
3. Worker's Compensation Policy or Policies in a form approved by the Insurance Commissioner of California covering all operations of the named insureds, as follows:

POLICY NUMBER	EFFECTIVE DATE	EXPIRATION DATE
_____	_____	_____
_____	_____	_____
_____	_____	_____

4. Said policy or policies shall not be canceled, nor shall there be any reduction in coverage or limits of liability, unless and until thirty (30) days' written notice thereof has been served upon the General Manager of the Morongo Basin Transit Authority.

\_\_\_\_\_

\_\_\_\_\_

By: \_\_\_\_\_  
Authorized Representative

## **INSURANCE REQUIREMENTS FOR THE MORONGO BASIN TRANSIT AUTHORITY**

### **PUBLIC WORKS CONTRACT**

The Contractor shall at all times during the terms of the contract carry, maintain, and keep in full force and effect, a policy or policies of comprehensive Public Liability Insurance with an insurance company acceptable to, and approved by, the General Manager and Attorney, with minimum limits of One Million Dollars (\$1,000,000.00), combined single limit coverage against any injury, death, loss or damage as a result of wrongful or negligent acts or omissions by the Contractor, together with an endorsement in substantially the form set forth below.

### **ENDORSEMENT**

It is hereby understood and agreed that the Morongo Basin Transit Authority, its Board of Directors and each member thereof, and every officer, agent (including but not limited to employees of Charles Abbott Associates, Inc. and all other Morongo Basin Transit Authority consultants) and employees of the Morongo Basin Transit Authority shall be named as jointly and severally insured as respects any and all claims arising out of the following project:

#### **BUS STOP AND SHELTER (IFB 19-01)**

It is further agreed that the following indemnity agreement between the Morongo Basin Transit Authority and the named insured is covered under the policy: Contractor agrees to indemnify, hold harmless and defend (with attorneys of the Morongo Basin Transit Authority's choice) the Morongo Basin Transit Authority, its Board of Directors and each member thereof and every officer, agent (including but not limited by this reference to employees of Charles Abbott Associates, Inc.) and employee of the Morongo Basin Transit Authority from any and all liability or financial loss resulting from any suits, claims, losses or actions brought against and from all cost and expenses of litigation brought against the Morongo Basin Transit Authority, its Board of Directors and each member thereof and any officer, agent (including but not limited by this reference to employees of Charles Abbott Associates, Inc.) or employee of the Morongo Basin Transit Authority which results directly or indirectly from the wrongful or negligent actions of the Contractor or the Contractor's officers, employees, agents or others employed by the Contractor while engaged by the Contractor in the performance of this agreement.

It is further agreed that the inclusion of more than one insured shall not operate to increase the limit of the company's liability and that insurers waive any right of contribution with insurance which may be available to the Morongo Basin Transit Authority, the Contractor's insurance being primary and not contributing with any other insurance available to the Morongo Basin Transit Authority and other above identified insureds.

In the event of cancellation or material change in the above coverage the company will give thirty (30) days written notice of cancellation or material change to the certificate holder (the Morongo Basin Transit Authority).

**INSTRUCTIONS FOR EXECUTION OF INSTRUMENTS  
FOR THE MORONGO BASIN TRANSIT AUTHORITY**

**THIS IS INSTRUCTION ONLY - IT IS NOT TO BE SIGNED OR USED IN CONJUNCTION WITH THE AGREEMENT OR ANY OTHER FORMS THAT MUST BE TURNED INTO THE MORONGO BASIN TRANSIT AUTHORITY - IT IS SIMPLY A FORMAT TO USE WHEN FILLING OUT DOCUMENTS.**

1. By an Individual. The individual must sign the instrument, and if he is doing business under a fictitious name, the fictitious name must be set forth. The signature must be acknowledged before a Notary Public, using the proper form of acknowledgment.
2. By a Partnership. The name of the partnership must be set forth followed by the signatures of less than all of the partners will be acceptable only if submitted with evidence of authority to act on behalf of the partnership. The signatures must be acknowledged before a Notary Public, using the proper form of acknowledgment.
3. By a Corporation. The name of the corporation must be set forth, followed by the signatures of the President or Vice President and Secretary or Assistant Secretary. The signatures must be acknowledged before a Notary Public, using in substance the following form of acknowledgment.
4. By a Surety. The name of the surety must be set forth, followed by an authorized signature. The signatures must be acknowledged before a Notary Public, using the proper form of acknowledgment.

STATE OF \_\_\_\_\_ )  
 ) SS.  
 COUNTY OF \_\_\_\_\_ )

On \_\_\_\_\_, 20\_\_\_\_, before me, the undersigned, appeared \_\_\_\_\_, known to me to be the President or Vice President and \_\_\_\_\_, known to be to be the (Secretary) (Assistant Secretary) of the corporation that executed the within instrument, and acknowledged to me that such corporation executed the within instrument pursuant to its by-laws or a resolution of its Board of Directors.

WITNESS my signature and seal.

\_\_\_\_\_  
Notary Public

(Seal)

## CONTRACT

### MORONGO BASIN TRANSIT AUTHORITY

THIS AGREEMENT is made and entered into this \_\_\_\_\_, by and between the MORONGO BASIN TRANSIT AUTHORITY, hereinafter referred to as "Morongo Basin Transit Authority," and \_\_\_\_\_ hereinafter referred to as "Contractor."

WITNESSETH:

WHEREAS, Contractor and Contractor's Surety are providing the bonds attached hereto as Exhibit B and incorporated by this reference, and

WHEREAS, Morongo Basin Transit Authority desires to contract with Contractor to perform the services detailed in this contract, including the Proposal, and

WHEREAS, Contractor has represented that it is fully qualified to assume and discharge such responsibility;

NOW, THEREFORE, the parties hereto do agree as follows:

1. Scope of Services - Morongo Basin Transit Authority hereby employs Contractor to perform the work and provide the services and materials as described in the Notice to Contractors, Instructions to Bidders, Special Provisions and the Proposal, attached hereto as Exhibit A and incorporated herein by this reference, including miscellaneous appurtenant work. Such work shall be performed in a good and workmanlike manner, under the terms as stated herein and in the Notice to Contractors, Instructions to Bidders, Special Provisions and the Proposal, and in accordance with the latest edition of the Joint Cooperative Committee, Southern California Chapters of the American Public Works Association and the Associated General Contractors of America, document entitled "Standard Specifications." In the event of any conflict between the terms of this agreement and any of the above-referenced documents, the terms of this agreement shall be controlling.
2. Compensation - In consideration of the services rendered hereunder, Contractor shall be paid according to the prices as submitted on the Pay Items and Bid Price Schedule of the Proposal, attached hereto as part of Exhibit A and in accordance with the Special Provisions.
3. Hold Harmless; Insurance - It is specifically understood and agreed by all parties hereto that Contractor is, for the purposes of this Agreement, an independent contractor and not an employee of the Morongo Basin Transit Authority. Accordingly, Contractor shall not be deemed the Morongo Basin Transit Authority's employee for any purpose whatsoever. Contractor shall not incur or have the power to incur any debt, obligation or liability whatever for or against Morongo Basin Transit Authority and shall hold harmless, indemnify and defend with the attorneys of the Morongo Basin Transit Authority's choice, the Morongo Basin Transit Authority its officers, employees, agents and representatives, from and against any and all obligations, claims, liens, or causes of actions, arising out of or related to Contractor's services hereunder. Contractor shall file and maintain with Morongo Basin Transit Authority at all times during the term of this Agreement, a copy or certificate of general liability insurance with an insurance company acceptable to, and approved by, the General Manager and Attorney of the Morongo Basin Transit Authority, with minimum limits of One Million Dollars (\$1,000,000.00) combined single limit coverage against any injury, death, loss or damage as a result of wrongful or negligent acts or omissions by the Contractor. Such insurance shall not be canceled without thirty (30) days' prior written notice to Morongo Basin Transit Authority, shall name the Morongo Basin Transit Authority and its officers and employees as additional insureds, shall include all automobiles utilized by Contractor's personnel in the

performance of this Agreement, and shall be primary and not contributing with other insurance available to the Morongo Basin Transit Authority.

4. Assignment - This agreement may not be assigned by the Contractor, in whole or in part, without the prior written consent of Morongo Basin Transit Authority.

5. Termination - This Agreement may be canceled by Morongo Basin Transit Authority at any time without penalty upon thirty (30) days' written notice. In the event of termination without fault of Contractor, Morongo Basin Transit Authority shall pay Contractor for all services rendered prior to date of termination, and such payment shall be in full satisfaction of all services rendered hereunder.

6. Worker's Compensation Insurance - In accordance with the provisions of Division 2, Part 7, Chapter 1, Article 5 (commencing with Section 1860) and Division 4, Part 1, Chapter 4 (commencing with Section 3700) of the Labor Code of the State of California, the Contractor is required to secure the payment of compensation to his employees and shall for that purpose obtain and keep in effect adequate Workers Compensation Insurance.

The undersigned Contractor is aware of the provisions of Section 3700 of the Labor Code which requires every employer to be insured against liability for worker's compensation or to undertake self insurance in accordance with the provisions of that Code, and will comply with such provisions before commencing the performance of the work of this contract.

7. General Rate of Per Diem Wages - Pursuant to the Labor Code of the State of California, the Director of Industrial Relations has determined the general prevailing rate of wages and employer payments for health and welfare, vacation, pension and similar purposes applicable to the work to be done. This rate and scale are on file with the General Manager and copies will be made available to any interested party on request. The Contractor to whom the contract is awarded, and the subcontractors under him must pay not less than these rates for this area to all workers employed in the execution of this contract.

8. Retention - In accordance with Part 5 (Section 2230), Division 2 of the Public Contract Code, a contractor may substitute securities for retention moneys withheld by a public agency to ensure performance under this contract. At the request and expense of the contractor, eligible securities equivalent to the amount withheld shall be deposited with the Morongo Basin Transit Authority, or with a state or federally chartered bank, as the escrow agent, who shall then pay such moneys to the contractor, and upon satisfactory completion of the contract, the securities shall be returned to the Contractor.

9. Suit; Recovery of Attorney Fees & Costs - Should either party bring any action to protect or enforce its rights hereunder, the prevailing party in such action shall be entitled to recover, in addition to all other relief, its reasonable attorney fees and court costs.

10. Morongo Basin Transit Authority Approval - All labor, materials, tools, equipment and services shall be furnished and work performed and completed under the direction and supervision and subject to the approval of Morongo Basin Transit Authority or its authorized representatives.

11. Gratuities - Contractor warrants that neither it nor any of its employees, agents, or representatives has offered or given any gratuities or promises to Morongo Basin Transit Authority's employees, agents, or representatives with a view toward securing this Contract or securing favorable treatment with respect thereto.

12. Conflict of Interest - Contractor warrants that he is and will continue to be in compliance with all applicable conflict of interest laws.

13. Contractor's Affidavit - After the completion of the work contemplated by this Contract, Contractor shall file with the General Manager his affidavit stating that all workmen and persons employed, all firms

supplying materials, and all subcontractors upon the Job have been paid in full, and that there are no claims outstanding against the Project for either labor or materials, except certain items, if any, to be set forth in an affidavit covering disputed claims or items in connection with a Stop Notice which has been filed under the provisions of the laws of the State of California.

14. Notice to Morongo Basin Transit Authority of Labor Disputes - Whenever Contractor has knowledge that any actual or potential labor dispute is delaying or threatens to delay the timely performance of the Contract, Contractor shall immediately give notice thereof, including all relevant information with respect thereto, to Morongo Basin Transit Authority.

15. Books and Records - Contractor's books, records, and plans or such part thereof as may be engaged in the performance of this Contract, shall at all reasonable times be subject to inspection and audit by any authorized representative of the Morongo Basin Transit Authority.

16. Legal Day's Work - Eight (8) hours labor constitutes a legal day's work.

17. Inspection - The work shall be subject to inspection and testing by Morongo Basin Transit Authority and its authorized representatives.

18. Discrimination - Contractor represents that it has not, and agrees that it will not, discriminate in its employment practices on the basis of race, creed, religion, national origin, color, sex, age or handicap.

19. Governing Law - This Contract and any dispute arising hereunder shall be governed by the law of the State of California.

20. Written notice - Any written notice required to be given in any part of the Contract Documents shall be performed by depositing the same in the U.S. Mail, postage prepaid, directed to the address of the Contractor as set forth in the Contract Documents, and to the Morongo Basin Transit Authority addressed as follows:

Mr. Mark Goodale, General Manager  
Morongo Basin Transit Authority  
62405 Verbena Road  
Joshua Tree, California 92252

21. Clayton/Cartwright Acts Assignment - The Contractor agrees to assign to the Morongo Basin Transit Authority all rights, title, and interest in and to all causes of action it may have under Section 4 of the Clayton Act (15 U.S.C. Sec. 15) or under the Cartwright Act (Chapter 2 (commencing with Section 16700) of Part 2 of Division 7 of the Business and Profession Code), arising from purchases of goods, services, or materials pursuant to the Public Works Contract. This assignment shall be made and become effective at the time the awarding body tenders final payment to the Contractor, without further acknowledgement by the parties.

22. Morongo Basin Transit Authority Claims - Morongo Basin Transit Authority does not waive any claims against Contractor by making any payment. The time limit for the Morongo Basin Transit Authority to assert claims against Contractor shall not be limited by the Contract Documents but shall be in accordance with the laws of the State of California.

(Signatures on the following page)



IN WITNESS WHEREOF, the parties hereto have executed the within Agreement the day and year first above written.

MORONGO BASIN TRANSIT AUTHORITY

CONTRACTOR:

\_\_\_\_\_  
Chairman of the Board of Directors

\_\_\_\_\_

ATTEST:

By: \_\_\_\_\_  
Title:

\_\_\_\_\_  
General Manager

By: \_\_\_\_\_  
Title:

"Corporate seal"

APPROVED AS TO FORM:

\_\_\_\_\_  
Attorney

APPROVED AS TO CONTENT:

\_\_\_\_\_  
General Manager

## APPENDIX



DURABILITY WITH DISTINCTION

**INSTALLATION  
INSTRUCTIONS  
FOR  
HIGH PEAK ROOF & GERARD TILE**

**TWENTY NINE PALMS, CA**

**TOLAR MANUFACTURING COMPANY INC.**

TRANSIT SHELTERS | STREET FURNITURE | DISPLAYS & DIRECTORIES | TRANSIT SOLAR LIGHTING  
258 Mariah Circle, Corona, CA USA 92879-1751 | 800-339-6165 | 951-808-0081 | [www.tolarmfg.com](http://www.tolarmfg.com)

### 4.3.4 Kwik Bolt TZ Expansion Anchor

#### 4.3.4.3 Technical Data

Table 1 — Kwik Bolt TZ Specification Table

SETTING INFORMATION	Symbol	Units	Nominal anchor diameter (in.)													
			3/8		1/2		5/8		3/4							
Anchor O.D.	$d_o$	In. (mm)	0.375 (9.5)		0.5 (12.7)		0.625 (15.9)		0.75 (19.1)							
Nominal bit diameter	$d_{bit}$	In.	3/8		1/2		5/8		3/4							
Effective min. embedment	$h_{ef}$	In. (mm)	2 (51)	2 (51)	3-1/4 (83)	3-1/8 (79)	4 (102)	3-3/4 (95)	4-3/4 (121)							
Min. hole depth	$h_o$	In. (mm)	2-5/8 (67)		2-5/8 (67)		4 (102)	3-3/4 (95)	4-3/4 (121)	4-5/8 (117)	5-3/4 (146)					
Min. thickness of fixture <sup>1</sup>	$t_{min}$	In. (mm)	1/4 (6)	3/4 (19)	1/4 (6)	3/8 (9)	3/4 (19)	1/8 (3)	1-5/8 (41)							
Max. thickness of fixture	$t_{max}$	In. (mm)	2-1/4 (57)		4 (101)	2-3/4 (70)	5-5/8 (143)	4-3/4 (121)	4-5/8 (117)	3-5/8 (92)						
Installation torque	$T_{inst}$	ft-lb (Nm)	25 (34)		40 (54)		60 (81)		110 (149)							
Min. dia. of hole in fixture	$d_h$	In. (mm)	7/16 (11.1)		9/16 (14.3)		11/16 (17.5)		13/16 (20.6)							
Available anchor lengths	$\ell_{anch}$	In. (mm)	3 (76)	3-3/4 (95)	5 (127)	3-3/4 (95)	4-1/2 (114)	5-1/2 (140)	7 (178)	4-3/4 (121)	6 (152)	8-1/2 (216)	10 (254)	5-1/2 (140)	8 (203)	10 (254)
Threaded length including dog point	$\ell_{thread}$	In. (mm)	7/8 (22)	1-5/8 (41)	2-7/8 (73)	1-5/8 (41)	2-3/8 (60)	3-3/8 (86)	4-7/8 (125)	1-1/2 (38)	2-3/4 (70)	5-1/4 (133)	6-3/4 (171)	1-1/2 (38)	4 (102)	6 (152)
Unthreaded length	$\ell_{unthr}$	In. (mm)	2-1/8 (54)		2-1/8 (54)		3-1/4 (83)		4 (102)							
Installation embedment	$h_{nom}$	In. (mm)	2-1/4 (57)		2-3/8 (60)	3-5/8 (92)	3-5/8 (92)	4-1/2 (114)	4-3/8 (111)	5-3/8 (137)						

<sup>1</sup> The minimum thickness of the fastened part is based on use of the anchor at minimum embedment and is controlled by the length of thread. If a thinner fastening thickness is required, increase the anchor embedment to suit.

Figure 1 — Kwik Bolt TZ installed

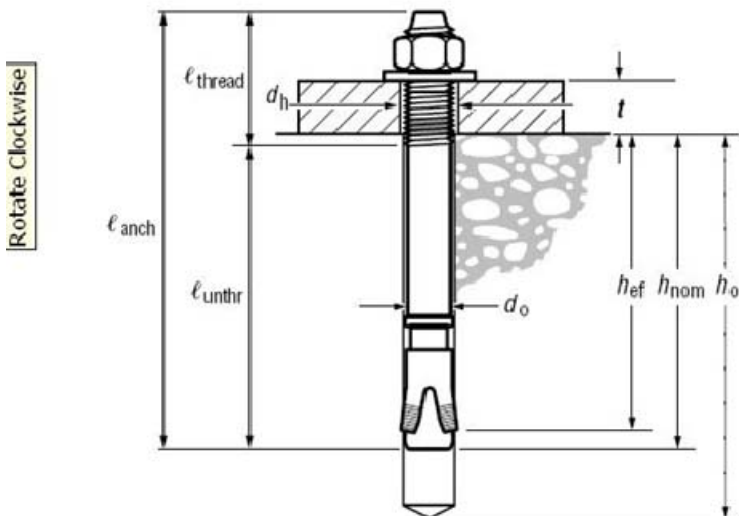

DATE	BY	DESCRIPTION	SCALE	APPENDIX
	A	REMOVE PIPE	4/17/05	
	B	FILE WAS. SITE MANIP PM 13 28 PALMS BRN 1A	7/25/07	

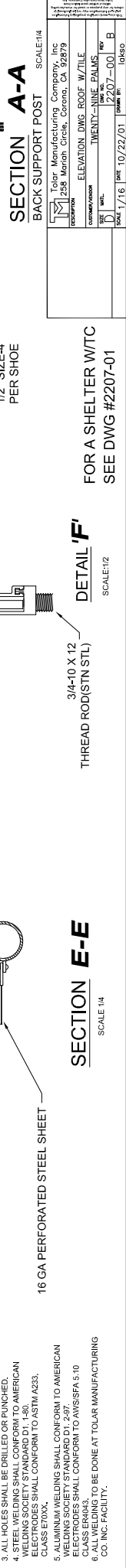
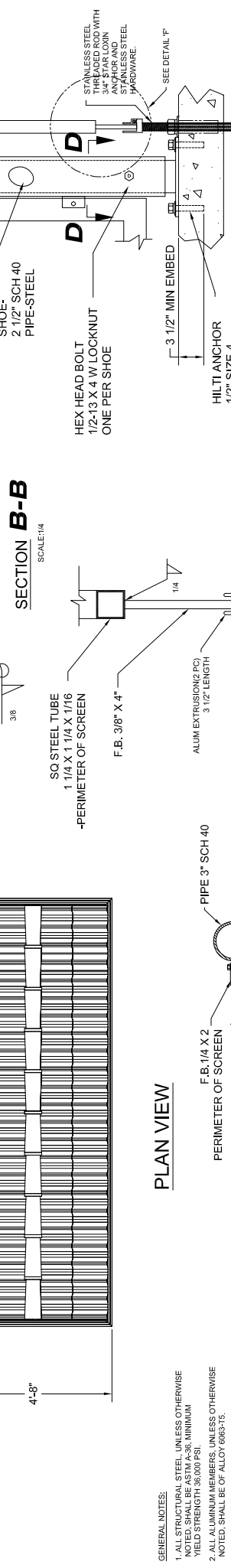
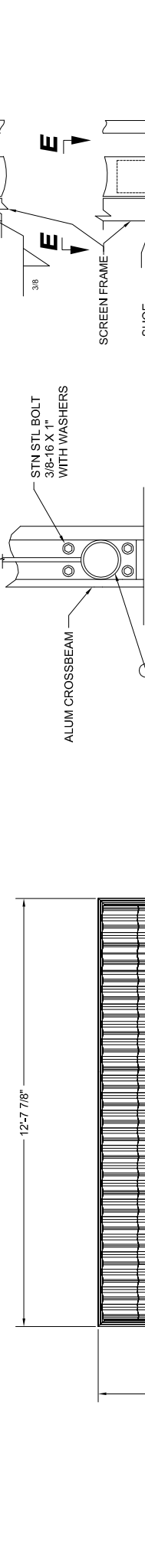
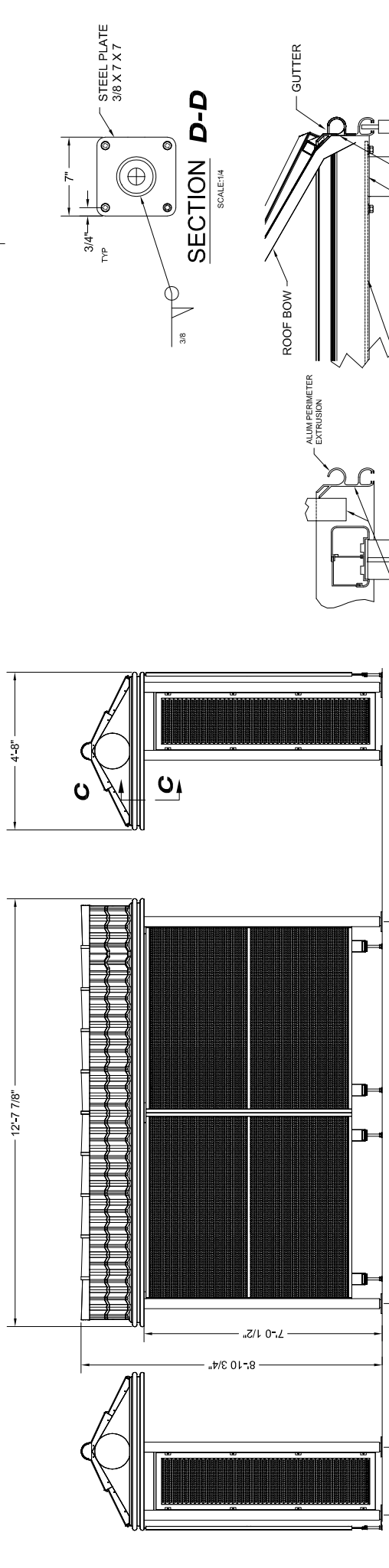

**DETAIL 'F'**  
 SCALE: 1/2"  
 Labels: 3/4-10 X 12 THREAD ROD (STN STL), 1/4".

**GENERAL NOTES:**

1. ALL STRUCTURAL STEEL, UNLESS OTHERWISE NOTED, SHALL BE ASTM A-36, MINIMUM YIELD STRENGTH 36,000 PSI.
2. ALL ALUMINUM MEMBERS, UNLESS OTHERWISE NOTED, SHALL BE OF ALLOY 6063-T5.
3. ALL HOLES SHALL BE DRILLED OR PUNCHED.
4. STEEL WELDING SHALL CONFORM TO AMERICAN WELDING SOCIETY STANDARD D1. 2.97. ALL WELDING SHALL CONFORM TO ASTM A233, CLASS E70XX.
5. ALUMINUM WELDING SHALL CONFORM TO AMERICAN WELDING SOCIETY STANDARD D1. 2.97.
6. ALL WELDING SHALL CONFORM TO AWS SFA 5.10.
7. ALL WELDING SHALL CONFORM TO AWS SFA 5.10.
8. ALL WELDING TO BE DONE AT TOLAR MANUFACTURING CO. INC. FACILITY.

**FOR A SHELTER W/TC**  
 SEE DWG #2207-01

**Tolar Manufacturing Company, Inc**  
 255 Marsh Circle, Corona, CA 92709  
 ELEVATION DWG ROOF W/TILE  
 PROJECT: TWENTY-NINE PALMS  
 DATE: 10/22/01  
 SCALE: 1/4"

**SECTION A-A**  
 SCALE: 1/4"  
 BACK SUPPORT POST

**SECTION B-B**  
 SCALE: 1/4"  
 ALUM CROSSBEAM

**SECTION C-C**  
 SCALE: 1/4"  
 ALUM PERIMETER EXTRUSION

**SECTION D-D**  
 SCALE: 1/4"  
 STEEL PLATE

**SECTION E-E**  
 SCALE: 1/4"  
 PERIMETER OF SCREEN

**DETAIL 'F'**  
 SCALE: 1/2"  
 THREAD ROD (STN STL)

## **ROOF SHEATHING & TILE INSTALLATION**

- 1. Place the 3/32" thick aluminum panel with battens over the bows of the roof. Install edges into grooves as shown in Fig 1 (Page 5). There should be a 1/2" gap between panels.**
- 2. Secure the panels with sheet metal screws TEKS (self drilling & tapping) #8 x 1/2. See Fig 2 (Page 6).**
- 3. Place the lower row of Gerard tile as shown on Page 7. Begin at the lower roof edge and overlap tiles from left to right. The smaller tile should be at the last one at the right end of the roof. Attach tile with TEKS screws # 8 x 1/2" or #8 x 3/4". Each tile should have 2-3 TEKS screws in the face (top) fastening into the alum tube batten underneath.**
- 4. Place the upper row of Gerard tile as shown on Page 7. Again, work from left to right finishing with the smaller tile. The upper row should press against the top alum tube batten and will overhang the bottom row. Fasten the upper row of tiles through the face and into the top batten with 2-3 TEKS screws # 8 x 3/4". Note: Gerard installation manual does allow exposed fasteners.**
- 5. Secure both rows of tiles at the middle batten. Install TEKS screws #8 x 3/4" approximately every 24" through both upper panels and lower panels and into batten.**

TOP VIEW OF ROOF PANEL

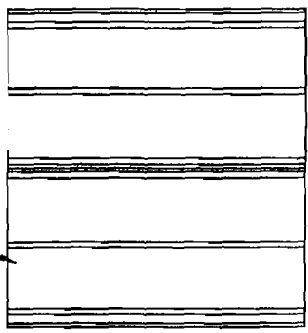

① LOWER ROOF PANEL

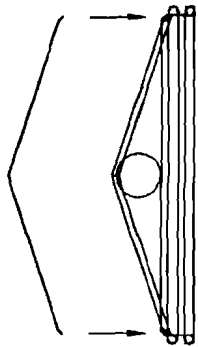

② INSERT ROOF PANEL

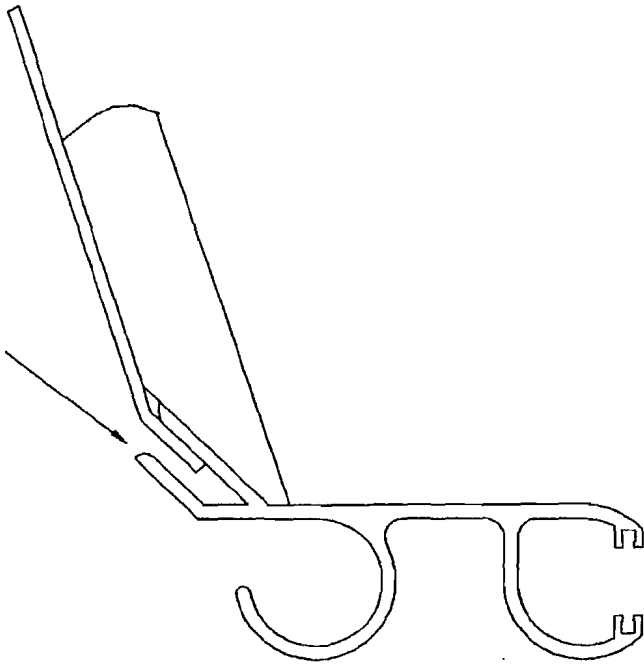

SHEET METAL SCREW (TEKS) #8 X 1/2"

APPROX. 1/2" GA

ALUMINUM SHEET

ROOF BOWS

ROOF END

③ SPACING

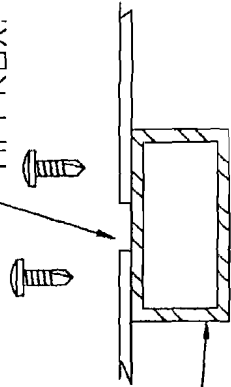
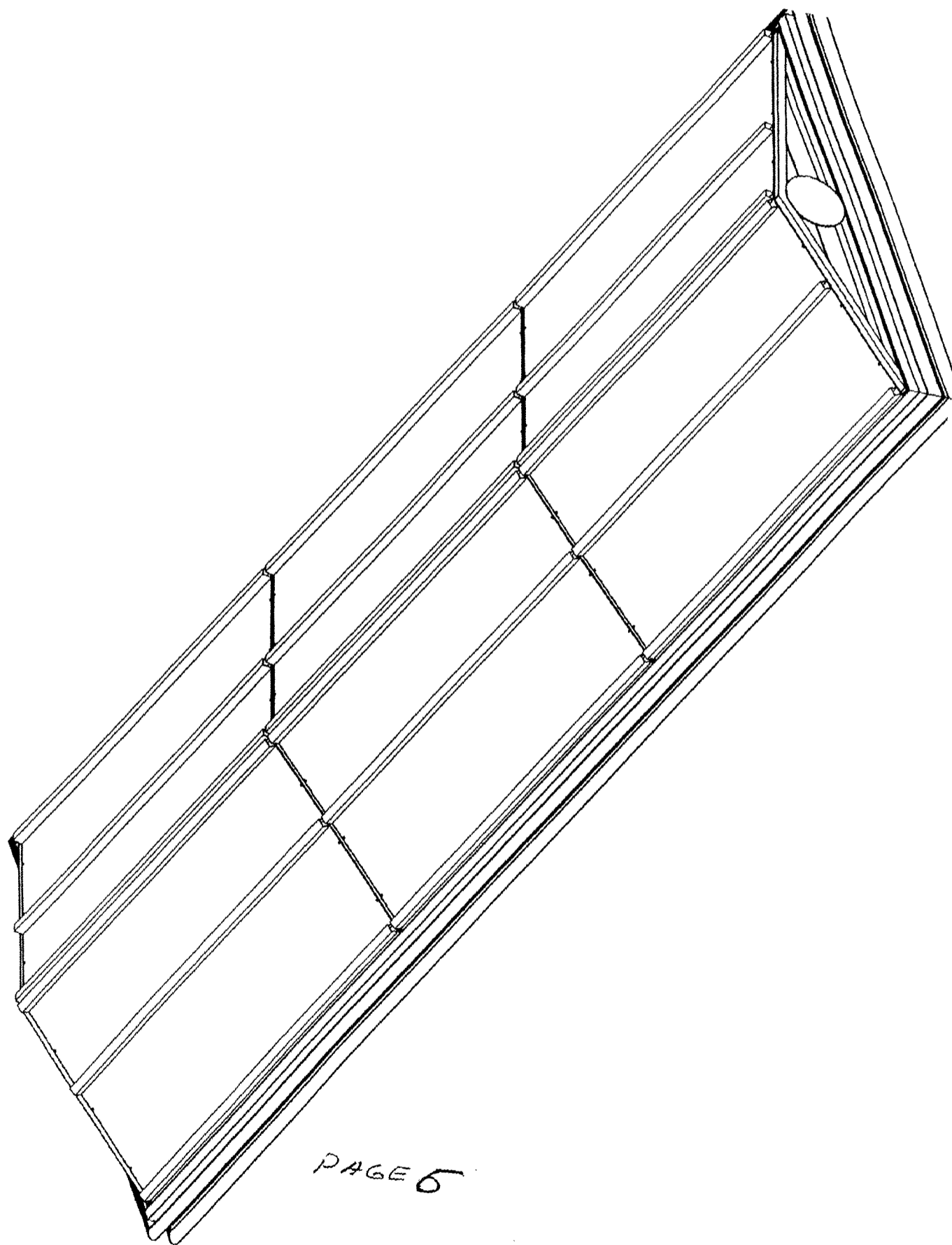
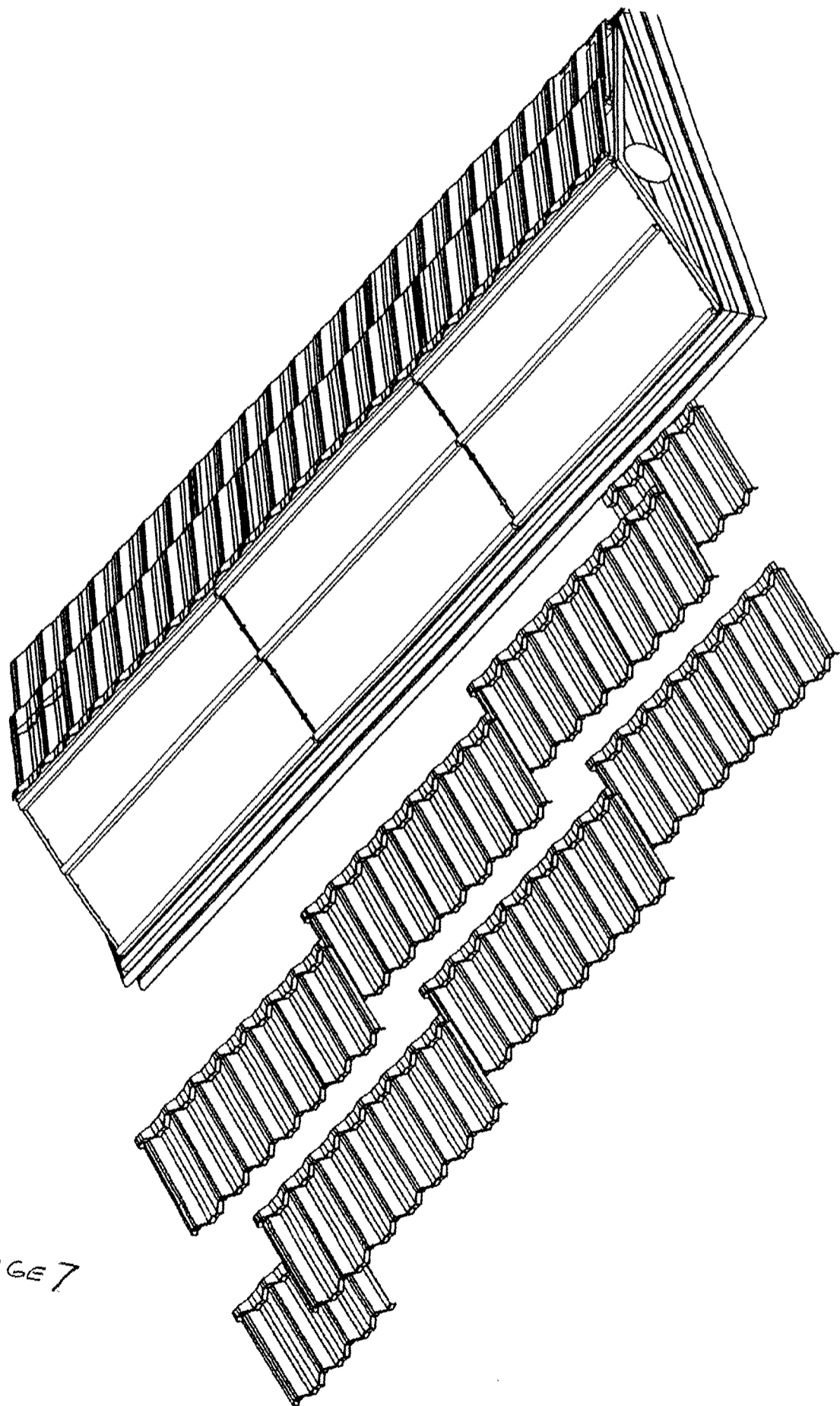

FIG 1



PAGE 6





PAGE 7

## **ROOF END CLOSEOUTS & RIDGE TILE**

- 1. Attach the 4 small panels & circle at each end of roof. Position the circle so that it fits inside ridge tile (SeePage 9) and inside the small panels. Use sheet metal screws TEKS #8 x 1/2".**
- 2. Place the first ridge tile at each end of roof just over the circle attached in step 1.**
- 3. Continue placing 5 ridge tiles from each end to meet at roof center. SeePage10.**
- 4. Fasten the ridge tiles by running a sheet metal screw (TEKS) flathead Philips #8 x 1 1/2" through the bottom edge of the ridge tile and into the tile below. Also use TEKS #8 x 3/4" as required.**

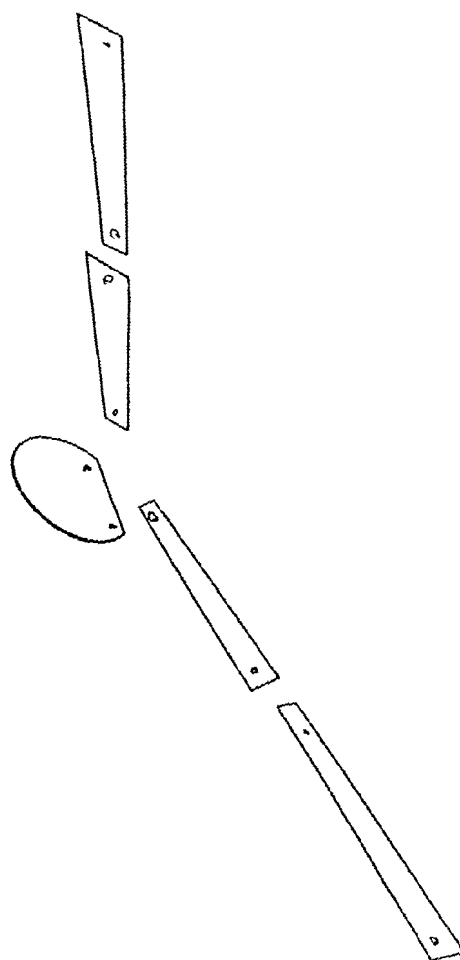
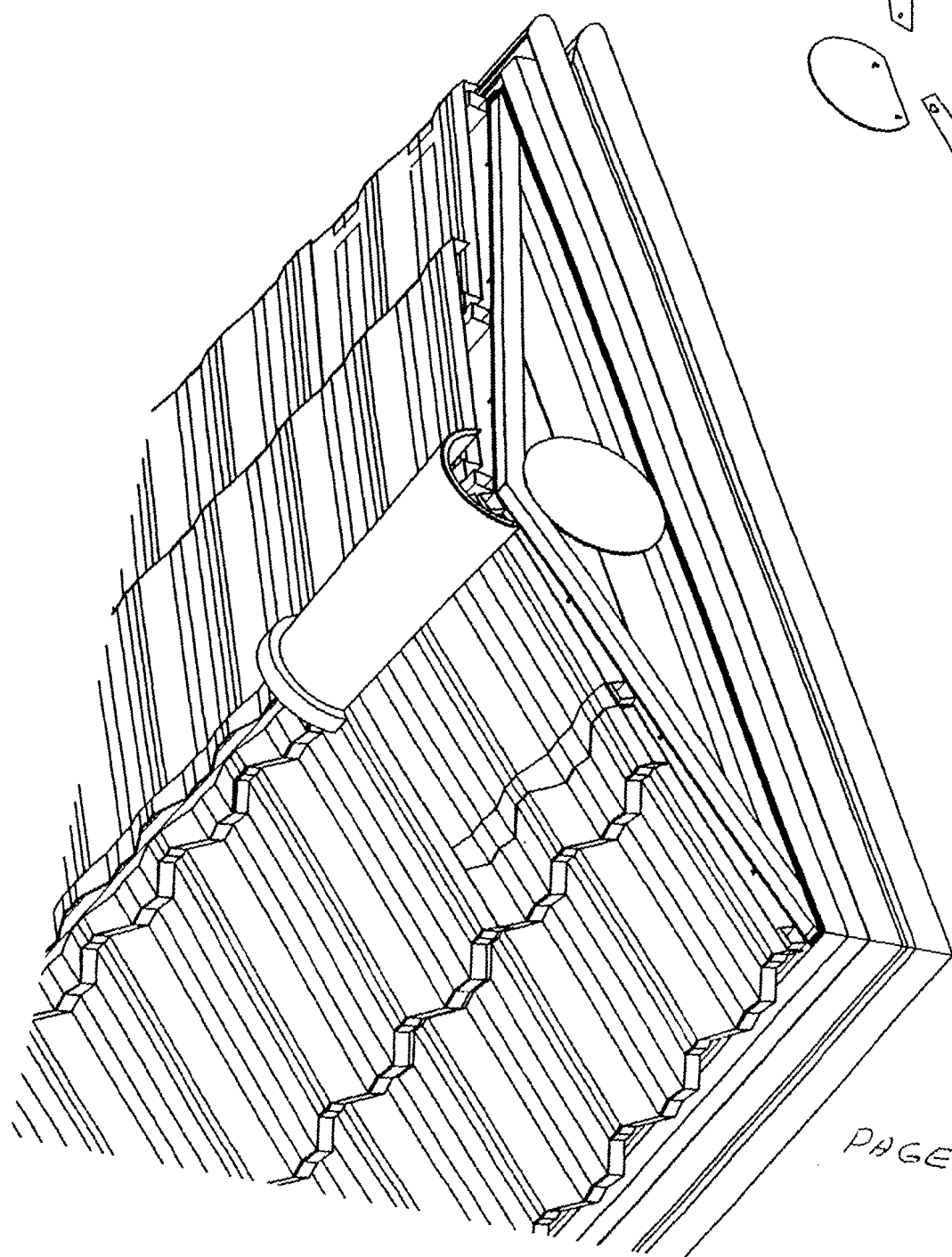

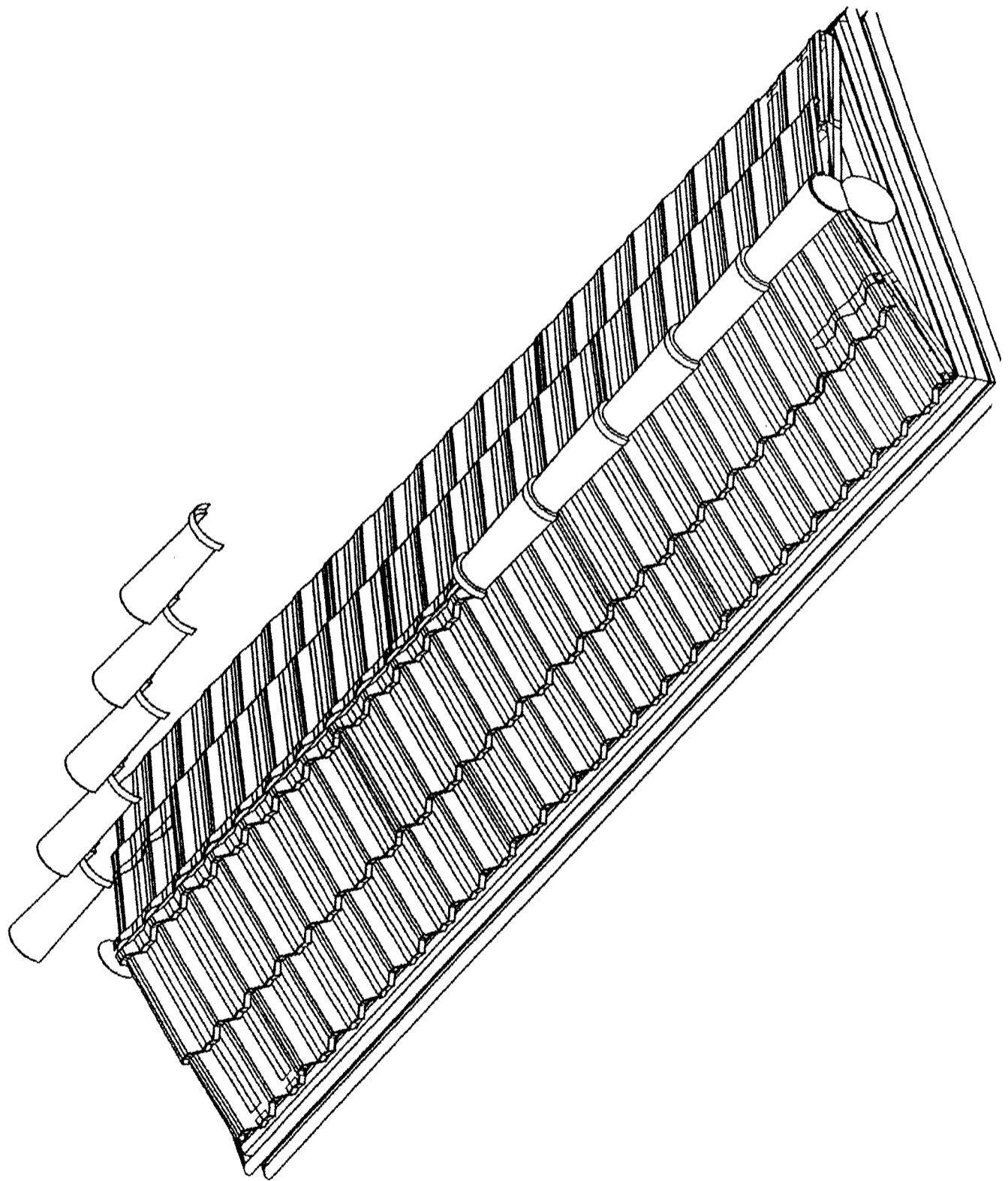

PAGE 10

## **ROOF INSTALLATION**

**SEE PAGE 12**

- 1. Slide the four 18" long shoes into the two support posts of each dual post assembly.**
- 2. Raise the roof (weight-175-250 pounds) and position the dual post assemblies under the roof crossbeams.**
- 3. Insert and tighten eight (8) each 3/8-16 x 1" Hex Head Bolts, 3/8 Lockwashers and 3/8 Flatwashers at the top of each dual post assembly.**
- 4. Level the roof by placing a carpenter's level on the roof's gutter. The roof height can be increased if desired. Drill a .50(1/2") diameter hole completely through the shoe. Install and tighten the 1/2-13 x 4" Hex Head Bolt at each post. Use the self-locking hexnut to secure. The small 1/4 diameter may be used initially to level the roof. Drill a .221(#2) diameter hole through the shoe. Hammer in a drive screw #14 x 3/4" long completely through the shoe pipe. It is not necessary to use this drive screw; some installers use it to level the roof preliminarily.**
- 5. Plumb the support posts and measure between the posts at each end. The measurement between posts should be 20 5/8" I.D. Force the posts in or out at the bottom to maintain this measurement. With a 3/8" diameter masonry drill, make four (4) holes in the concrete using each support leg shoe as a hole locator. Place the 3/8" size Hilti anchors into the holes. Secure each shoe with the anchors.**

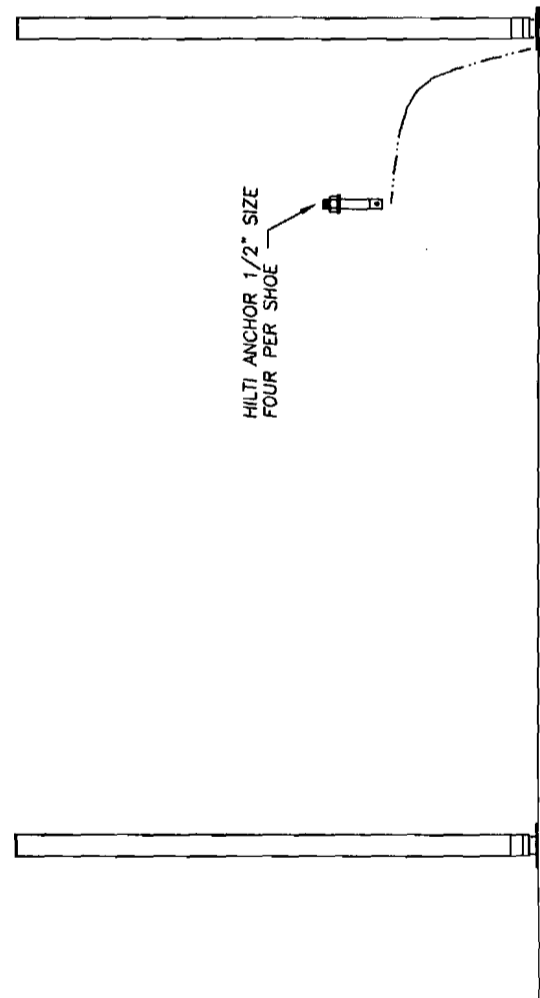
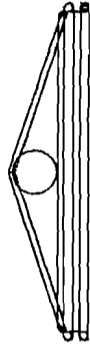

FRONT VIEW

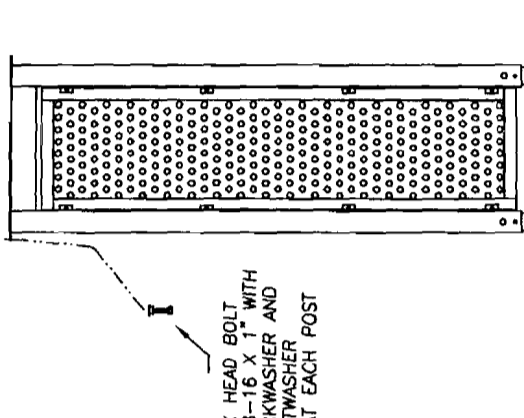

2'-0 1/8"

END VIEW

### ROOF INSTALLATION (TYPICAL)

## REAR SCREENS INSTALLATION

1. See PAGE 14 and the Elevation Drawing PAGE 3. Drop a plumb line from the rear screen insertion groove of the roof perimeter. Mark the concrete near both ends of the roof and snap a chalk line. The rear screen support/anchor assemblies will be inserted on this line. Mark the chalk line at the intervals shown on the elevation drawing. These marks will be the proper spacing for the support/anchor assemblies. The first support/anchor assembly at either end must be at least 4" in from end of roof.
2. Drill four(4) 1 1/4" diameter holes into the concrete on the marks with a masonry drill. These holes should be at least 8" deep and may penetrate into the grade below the concrete. This depth is required to allow clearance for the threaded adjusting rod. Clean out holes.

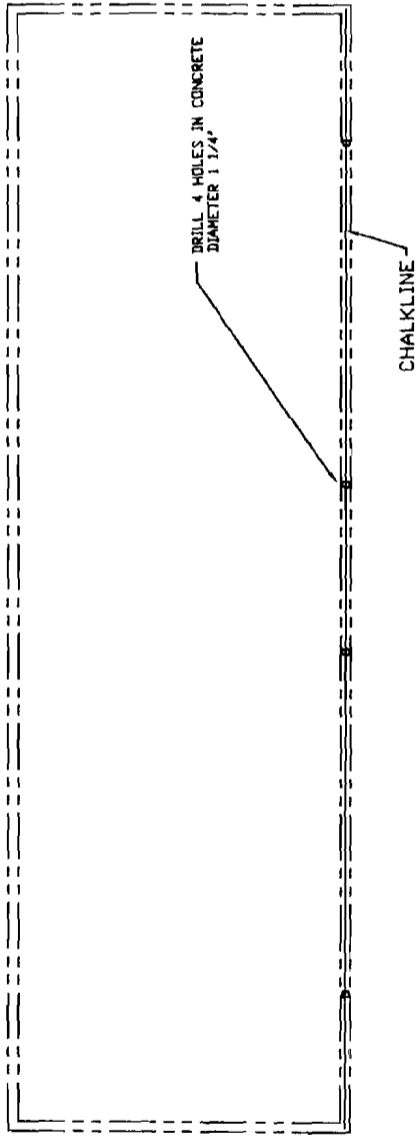

PLAN VIEW

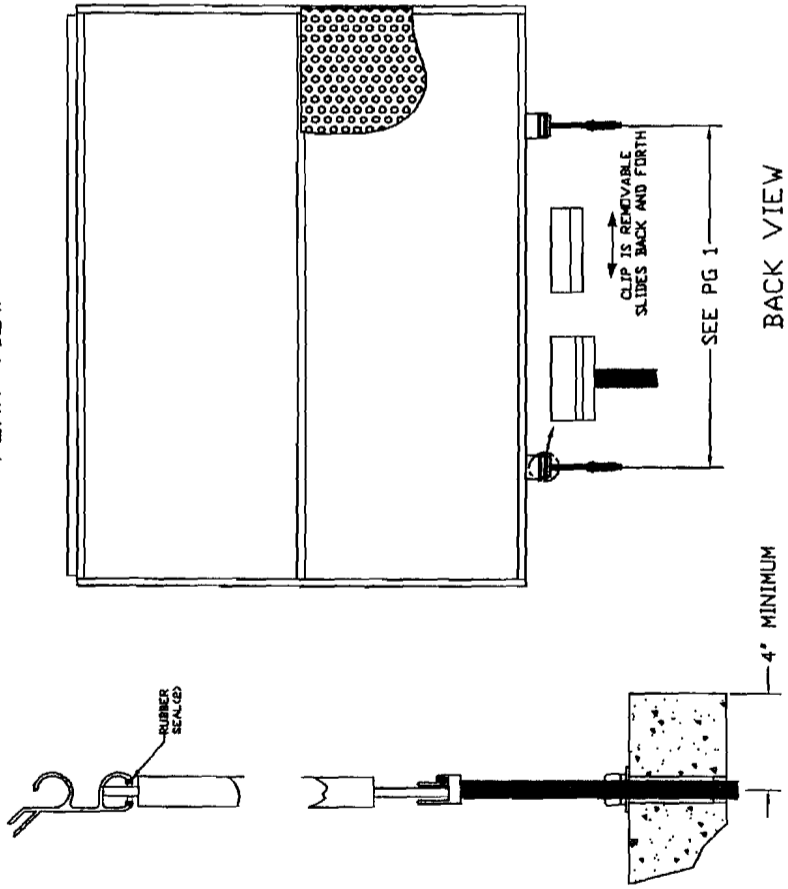

REAR PANELS INSTALLATION(TYPICAL)



3. Place the bottom screen support/anchor assemblies into the holes. The top surface of the anchor itself should be flush to concrete or 1/2" below. The total height of the screen is 81". Measure from inside the screen insertion groove to the screen support anchor. Rotate the threaded rod inside the anchor to adjust height. Tighten the 3/4-10 hexnut to expand and secure anchor. Slide screen up into screen insertion groove and onto bottom screen support/anchor assemblies (separate clip can be slid off). Replace clip.

### END SCREEN INSTALLATION

1. Install end screens. Holes in screen frame correspond to holes in tabs attached to post. See screen installation PAGE 16

### BENCH INSTALLATION

1. Place bench at one end of shelter. Allow 30" x 48" minimum space at end of bench for wheelchair access.
2. Using the shoes of the bench as a template, mark the anchor locations onto the concrete.
3. Move bench and drill four holes with 3/8" diameter masonry drill. These holes must be 2 1/2" deep.
4. Position bench and install 3/8" Hilti anchors.

..\\..\\AutoCAD2000\\Installations\\Plots\\Fig1.dwg  
..\\..\\AutoCAD2000\\Installations\\Plots\\Fig2.dwg  
..\\..\\AutoCAD2000\\Installations\\Plots\\Fig3.dwg  
..\\..\\AutoCAD2000\\Installations\\Plots\\Insscn13.dwg  
..\\..\\AutoCAD2000\\Installations\\Plots\\Insscn04.dwg  
..\\..\\AutoCAD2000\\Installations\\Plots\\INSRF13 Perf Elec Non Ad.dwg  
..\\..\\AutoCAD2000\\Shelters\\Non Ad Low Dome\\S NALD PM 13 Conroe 1.dwg

# END SCREEN INSTALLATION

## NOTES:

1. INSTALL SCREEN OUTSIDE OF TABS ON PIPE OR INSIDE OF TABS, USE YOUR DISCRETION.
2. LOOSEN BOLTS AT TOP OF POSTS AND THE ANCHORS AT BOTTOM TO ALLOW FITTING OF SCREEN.
3. INSTALL THE TAMPERPROOF SCREW THROUGH THE SCREEN FRAME FIRST THEN THROUGH THE TAB.

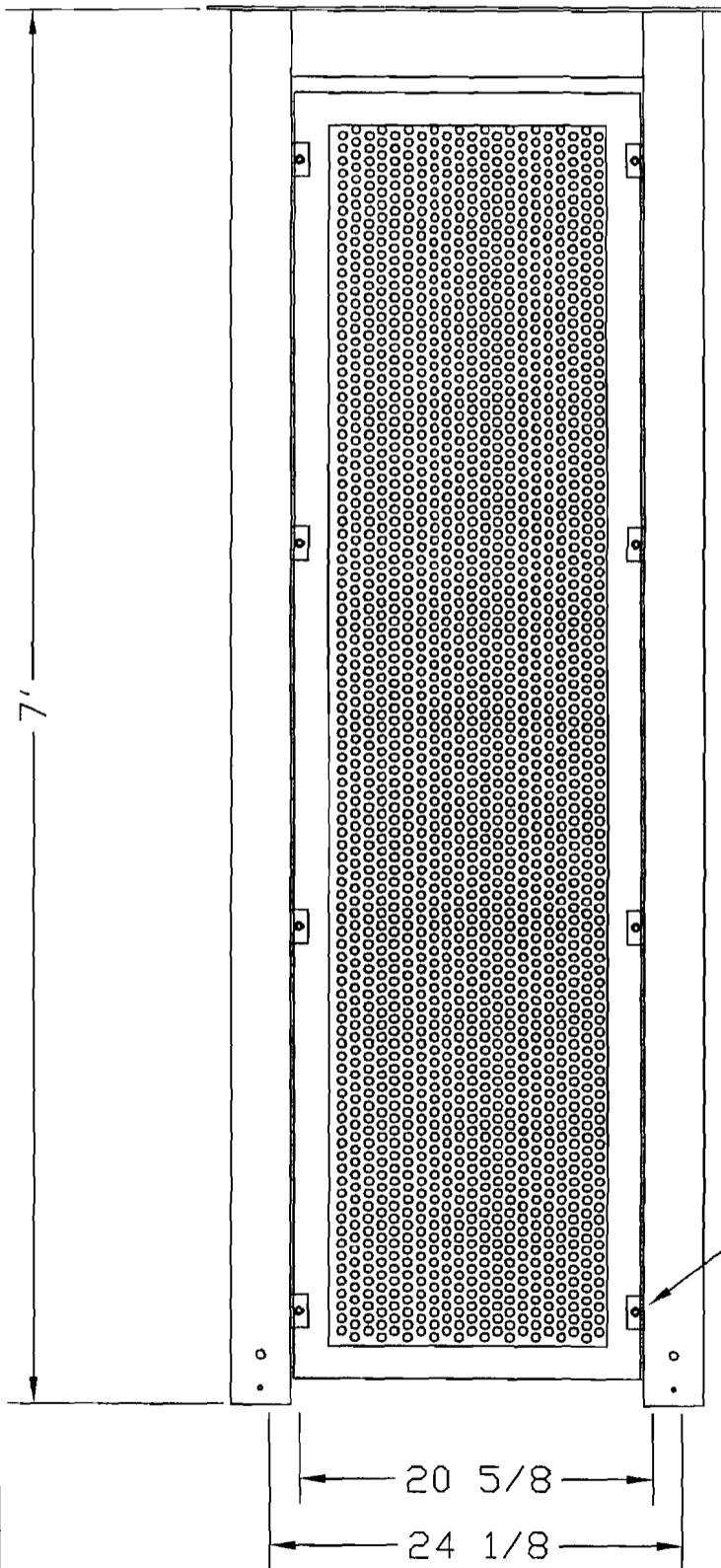

INSTALL WITH EIGHT  
SCREWS 1/4-20 X 1  
AND SELFLOCK NUT-  
USE FLATWASHER AGAINST  
SLOTTED HOLE.



# **Urban Solar Corporation**

## **RMS 60F PV Shelter**

### **TRANSIT SHELTER SOLAR-POWERED LED LIGHTING SYSTEM**

Date: April 1, 2009

Revision: A

# Introduction

The Urban Solar Corporation RMS-60F stand alone solar powered LED lighting system has been designed specifically to meet the requirements for lighting the barrel roof type transit shelter. The system has been engineered to integrate with the shelter's mechanical design in order to provide an aesthetic look and a very simple installation procedure.

## How it works

The RMS-60F shelter lighting system provides dusk till dawn lighting using LED light fixtures, batteries, and solar panels, integrated with an energy control module (ECM). Electricity generated from the solar panels is directed to the ECM which controls the charging of the battery bank. The ECM senses darkness using the solar panel voltage, and switches on the power to the LEDs.

The main system components are described below:

**PV Array (solar module)** - The PV array consists of two 32 W flexible solar modules mounted to flexible metal framework. The solar panel array size is sufficient to provide enough solar charging for the system to operate dusk till dawn, at a specific brightness level, year round at a given geographical location.

**Batteries**- The battery bank is composed of three 18 amp-hour 12 Volt cells. The batteries are sealed, lead acid, rechargeable, and provide a minimum of 5 days autonomy (i.e. the system could operate for a minimum of 5 days with absolutely no solar charging – for example during heavy snowfall).

**Luminaires**- The LED luminaires contain high power white LEDs. The luminaires are driven well below their maximum power rating to increase efficiency and extend the already long life.

**ECM** - The Energy Control Module is the central control of the lighting system. It controls battery charging and regulates the power to the LED luminaires. The ECM also monitors the system performance to ensure the batteries will not be damaged by over charging, and will turn off the LEDs if the battery voltage falls below the low voltage disconnect (LVD) setting. Once the batteries have been sufficiently charged above the LVD, the ECM will turn the LEDs back on again. The ECM is factory programmed for a specific operating profile based on the customer requirements for LED on-time and brightness level, and depends on the geographical location and solar array size. Using a calendar based approach, the LED light levels and on-times can be optimized for maximum performance year round.

## 2. Assemble and Install the RMS-60F

Before assembling your RMS 60F solar lighting system it is necessary to identify the major components of the system and verify the following parts list:

### RMS-60F components

Power module



Power Module with LID removed (shown with ECM and batteries)

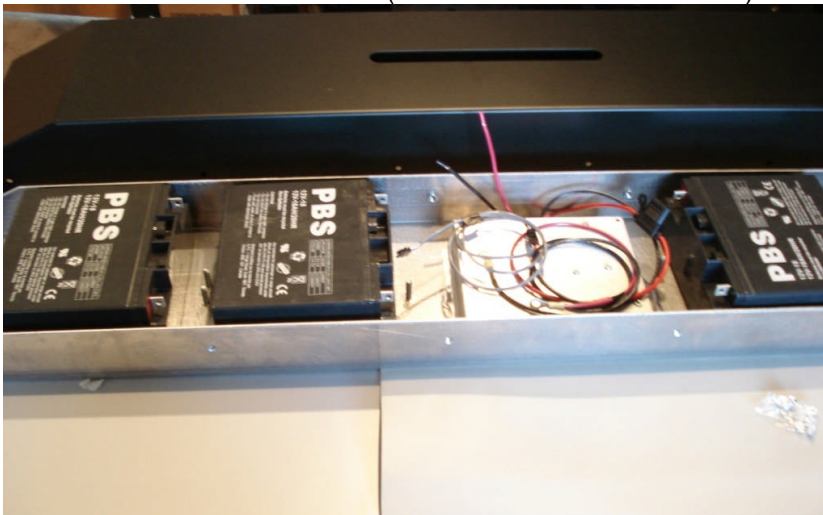

Batteries and Brackets (3)



Solar Module Assembly (Qty: 2)

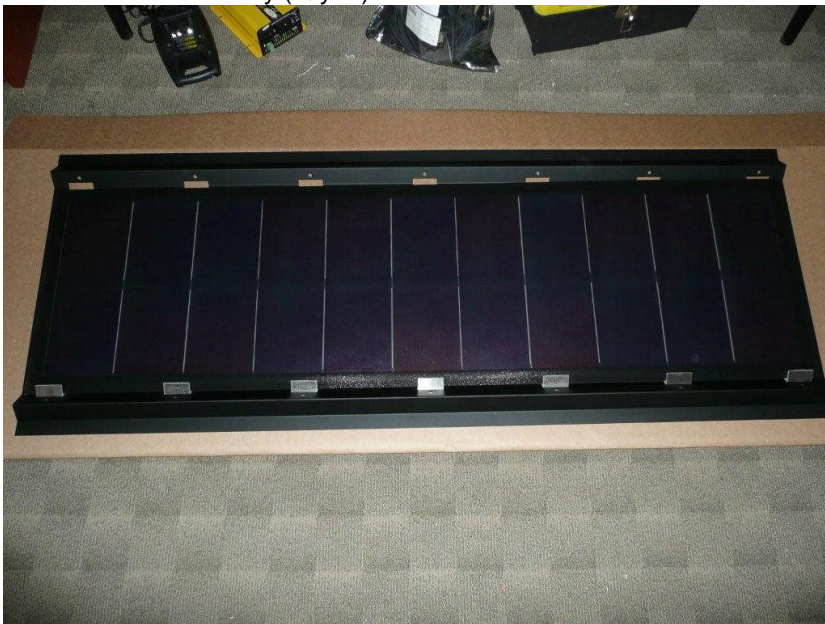



ECM with Solar, LED and Battery connections

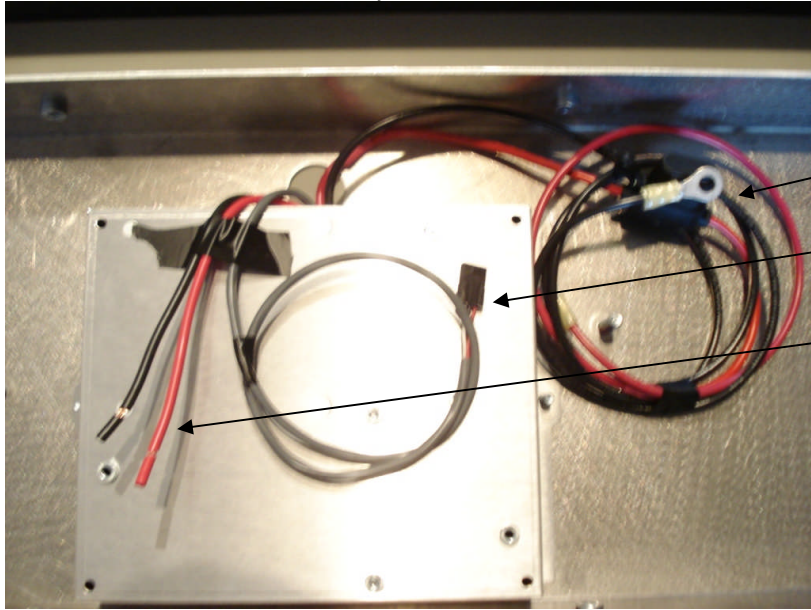

Battery Harness

Luminaire Connection

Solar Connection

Battery Jumper Harnesses:

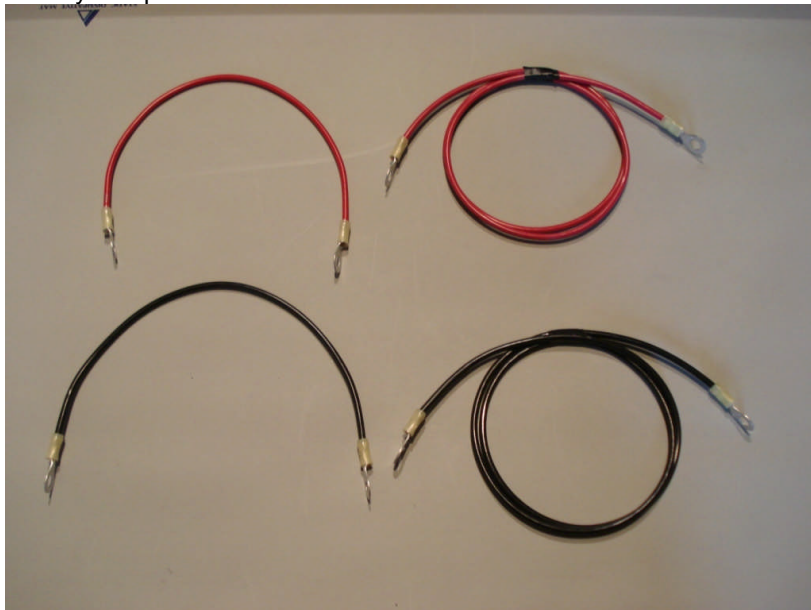

Installation Hardware:

12 pcs TR-27, SECURITY SCREW, 1/4-20 X 1, SELF-TAPPING

If you have not received all of the above components please contact Urban Solar.

## Installation and Assembly

1. Please read the entire installation procedure before starting as the order of operations is optional.
2. Remove Power Module Lid then remove battery straps and jumper harnesses. Note that the battery bracket bolts do not need to be removed entirely.
3. Determine the mounting location on the ceiling of the shelter. The power module base should be positioned so that it can be secured to the shelter roof ribs near each end – i.e. centered on two roof ribs. Typically the module will be positioned at the center of the shelter. Using appropriate hardware (TR-27 ¼-20 x 1, self tapping), mount the power module base to the ceiling and ensure it is secured with a minimum of four (4) screws fastened directly through the roof ribs. Pilot holes will have to be drilled in the power module base and roof ribs – use a 13/64 drill bit for the pilot holes.

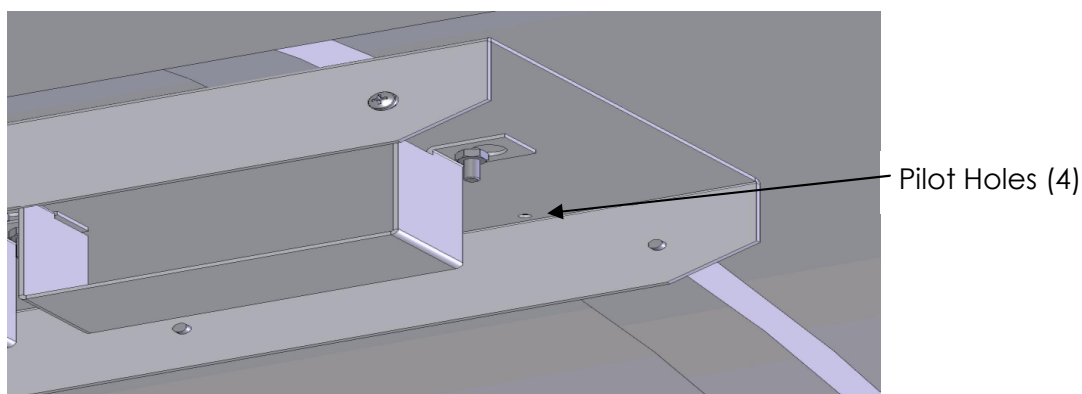
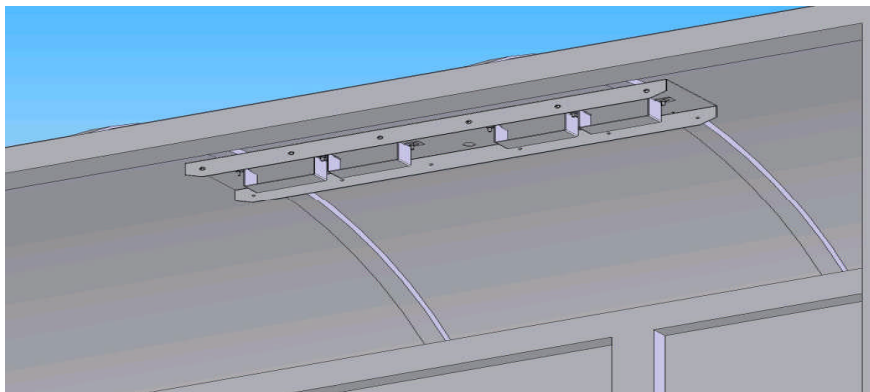



Note – the following steps (4-7) can be performed before the module is mounted to the shelter ceiling as it may be easier to do in the shop – it is at the discretion of the installation crew. It will make mounting to power module to the ceiling of the shelter more difficult because of the weight of the batteries, but makes battery wiring much easier.

4. Insert batteries in to the power module and secure with the battery hold down straps provided.



**USE EXTREME CAUTION WHEN INSTALLING BATTERY HARNESES. ALWAYS WEAR INSULATING GLOVES WHEN CONNECTING BATTERIES. AVOID CONTACT OF FREE POSITIVE RING TERMINALS WITH NEGATIVE TERMINALS OF BATTERY OR ANY PART OF THE CHASSIS**

**Be cautious when handling the battery pack. It is capable of generating hazardous short-circuit currents. Remove all jewelry (bracelets, metal-strap watches, rings) before attempting to handle or disassemble the battery pack. Contact Urban Solar if further instruction is required.**

#### **REFER TO WIRING DIAGRAM FOR COMPLETE WIRING DETAILS**

5. Battery wiring – batteries are wired in PARALLEL. Use the 2 black jumper cables to connect all of the black terminals together, and use the 2 red jumper cables to connect all the red terminals together.
6. Attach the black main negative battery power cable coming from the ECM to one of the negative battery terminals.
7. Attach the red fused main positive battery power cable coming from the ECM to one of the positive battery terminals.
8. Use wire ties to tidy up wiring and tuck neatly out of the way.

## RMS 60F Wiring Diagram

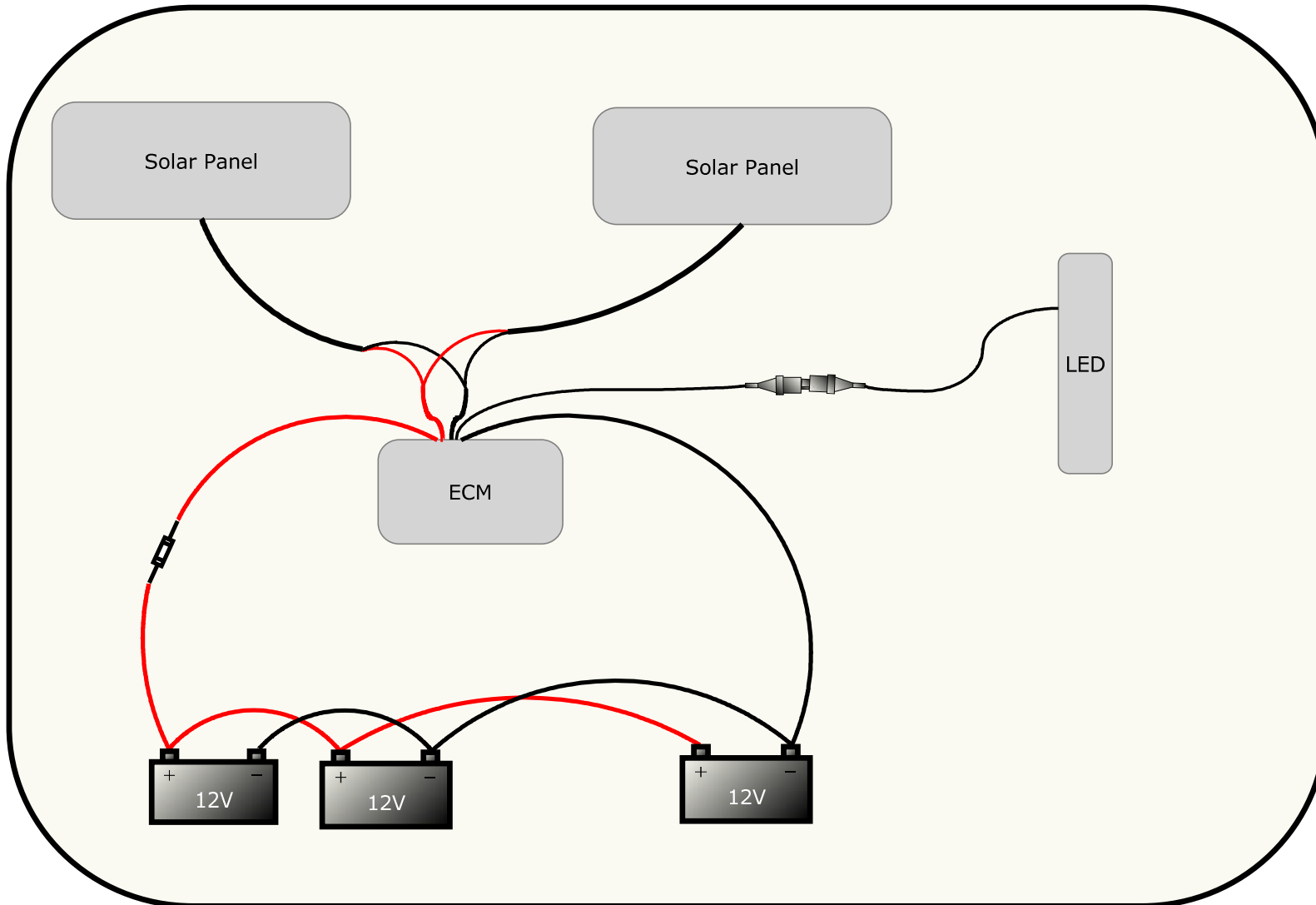

## Install solar panels on shelter roof

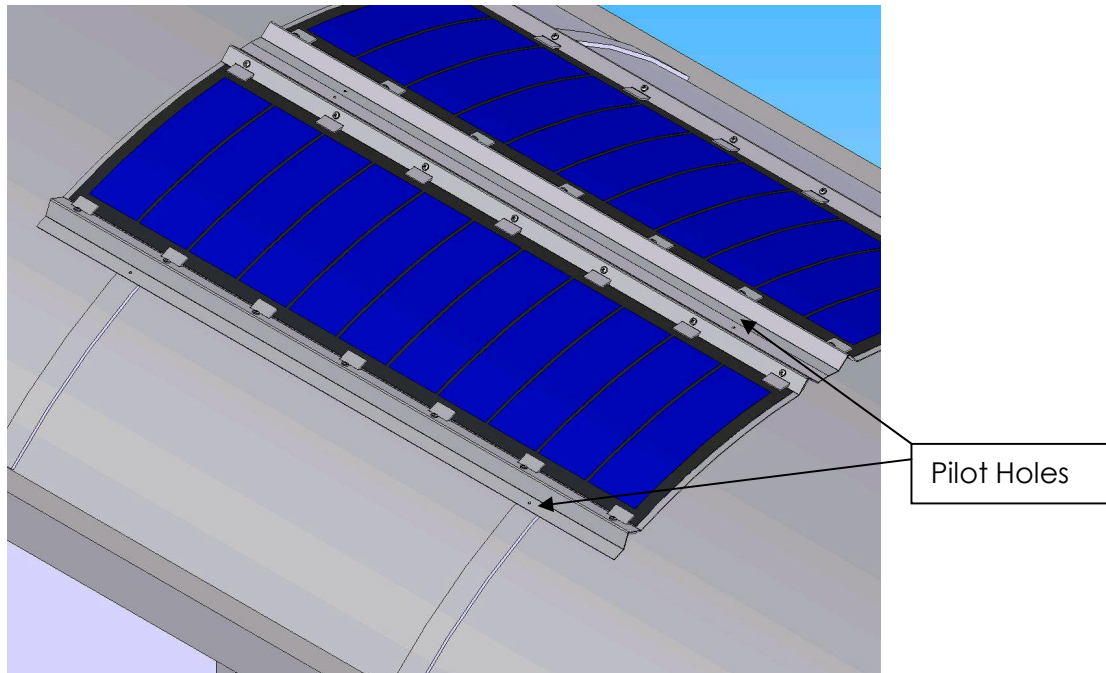

9. Determine solar panel positioning then mark and drill holes for mounting to the shelter roof ribs.
10. Drill a hole through the roof into the power module for routing the solar panel wiring. The hole should line up with one of the larger wire feed through holes in the power module base.

11. Route the solar panel wires through to the power module then secure panels to the roof using security screws provided. The panels will flex to conform to the radius of the shelter roof.

**Caution – do not short the solar panel positive leads to the negative leads or to any part of the metal work on the chassis or shelter. Use electrical tape to insulate leads when routing solar panel wiring.**

12. The panels are also wired in parallel. Connect both positive solar leads to the positive (red) lead from the ECM as shown. Connect both negative solar leads to the negative (black) lead from the ECM. Use marrettes (wire nuts) to make connections.
13. Hold the power module lid up and make the connection for the luminaire to the control module as shown.
14. Coil up any excess wiring and use wire wraps or zip ties to neaten up and tuck away all wiring.
15. Replace the power module lid and secure with fasteners provided.

The RMS-60F installation process is now complete. The LEDs will turn on approximately 30minutes after dusk.

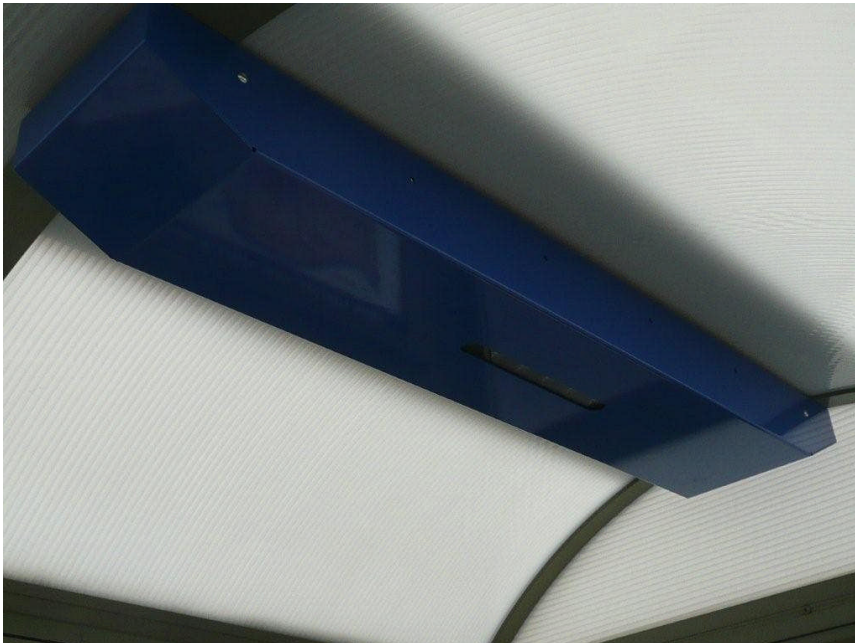

## Troubleshooting

This section describes what to do if the RMS 60F is not operating properly. If RMS 60F does not operate according to its specifications, check the following:

Make sure that all wiring connections have been made exactly as detailed in this manual.

Check the voltage across the battery terminals. The battery voltage must be > 11.8Volts for the system to operate. Make sure the polarity is correct.

Check the fuse in the positive battery lead.

Check the voltage across the solar panel leads. On a typical day the voltage should read between 15 to 24 Volts. Also make sure the polarity is correct.

Please contact Urban Solar Corporation for assistance.

## Maintenance/ Product Care

Although the system is designed to be maintenance free, optimal performance requires clean solar panels. Clean on an annual basis or as required. Use water and a soft sponge or cloth for cleaning and a mild, non-abrasive cleaning agent for more stubborn residue. Rinse well.

### Batteries

Be cautious when handling the battery pack. It is capable of generating hazardous short-circuit currents. Remove all jewelry (bracelets, metal-strap watches, rings) before attempting to handle or disassemble the battery pack. Contact Urban Solar if further instruction is required.

**Consult your local municipal by-laws for information on recycling the cells.  
DO NOT THROW THE CELLS IN THE GARBAGE!**

## Contact and re-order information

If you have any questions or feedback we would like to hear from you. Please visit our website or feel free to contact us directly at 778-430-5516 or [techsupport@urbansolarcorp.com](mailto:techsupport@urbansolarcorp.com)

Urban Solar Corporation

4211 Commerce Circle

Victoria, BC Canada, V8Z 6N6

[www.solarlightingfortransit.com](http://www.solarlightingfortransit.com)

# Appendix A: RMS 60F - Exploded View

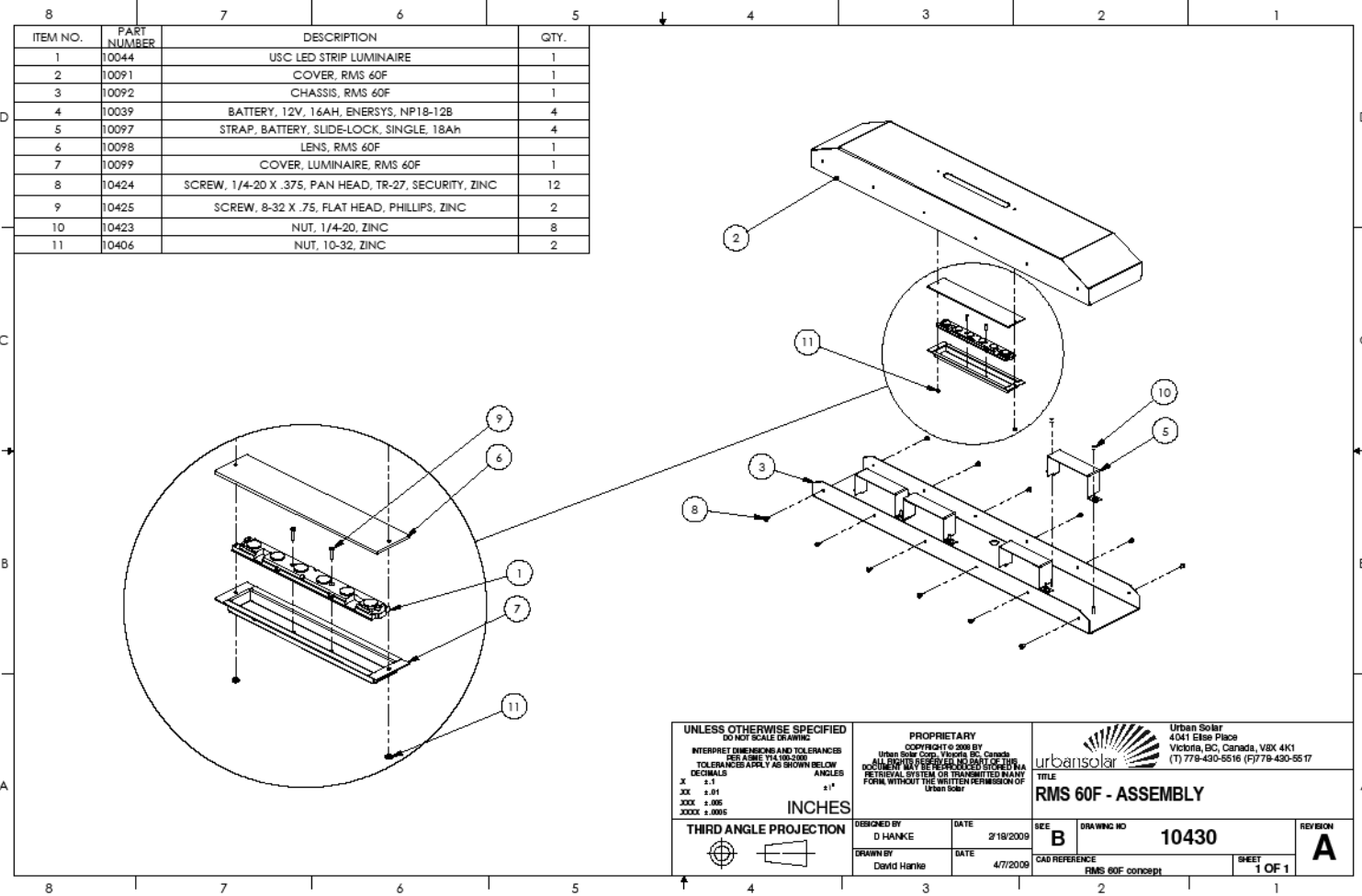

<p>UNLESS OTHERWISE SPECIFIED DO NOT SCALE DRAWING INTERPRET DIMENSIONS AND TOLERANCES PER ASME Y14.100-2009 TOLERANCES APPLY AS SHOWN BELOW</p> <p>DECIMALS ±.1 XX ±.01 XXX ±.005 XXXX ±.0005</p> <p>ANGLES ±1°</p> <p><b>INCHES</b></p> <p>THIRD ANGLE PROJECTION</p>	<p>PROPRIETARY COPYRIGHT © 2009 BY Urban Solar Corp, Victoria BC, Canada NO PART OF THIS PUBLICATION IS TO BE REPRODUCED OR TRANSMITTED IN ANY FORM WITHOUT THE WRITTEN PERMISSION OF Urban Solar</p>	<p>Urban Solar 4041 Elser Place Victoria, BC, Canada, V8X 4K1 (778) 430-5516 (F) 778-430-5517</p>		
	<p>TITLE <b>RMS 60F - ASSEMBLY</b></p>			
<p>DESIGNED BY D HANKE</p>	<p>DATE 2/19/2009</p>	<p>REV <b>B</b></p>	<p>DRAWING NO <b>10430</b></p>	<p>REVISION <b>A</b></p>
<p>DRAWN BY David Hanke</p>	<p>DATE 4/7/2009</p>	<p>CAD REFERENCE RMS 60F concept</p>	<p>SHEET <b>1 OF 1</b></p>	



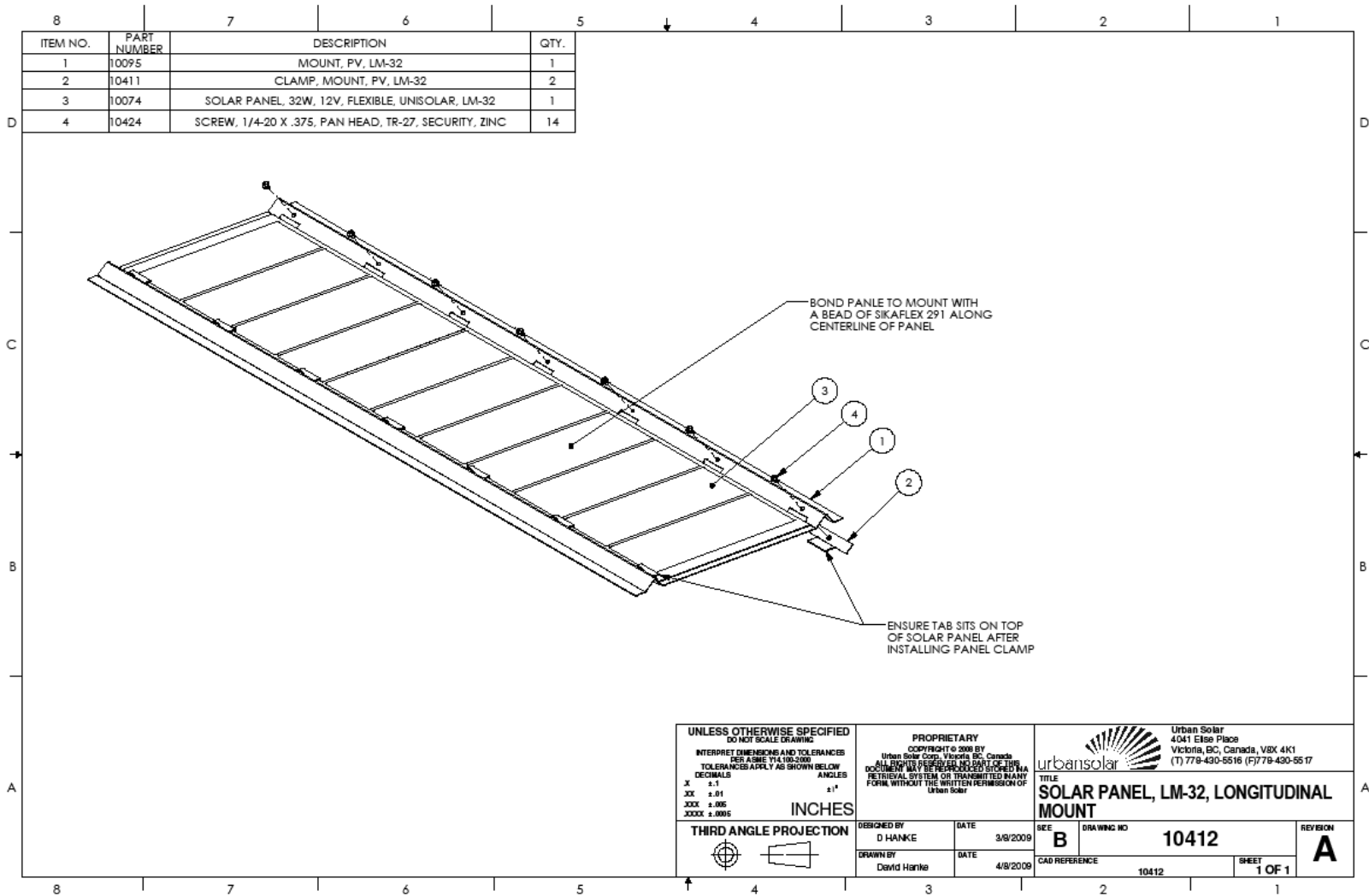



STATE OF CALIFORNIA · DEPARTMENT OF TRANSPORTATION  
**ENCROACHMENT PERMIT**  
 TR-0120 (REV. 6/2012)

Permit No. 08-19-N-BS-0680	
Dist/Co/Rte/PM 08-SBD-62, PM 10.443	
Permit Approval Date 06/26/2019	
Fee Paid \$ EXEMPT	Deposit \$ EXEMPT
Performance Bond Amount (1) \$ 0.00	Payment Bond Amount (2) \$ 0.00
Bond Company	
Bond Number (1)	Bond Number (2)

In compliance with (Check one):

- Your application of \_\_\_\_\_ May 30, 2019
- Utility Notice No. \_\_\_\_\_ of \_\_\_\_\_
- Agreement No. \_\_\_\_\_ of \_\_\_\_\_
- R/W Contract No. \_\_\_\_\_ of \_\_\_\_\_

TO: Morongo Basin Transit Authority (MBTA)  
 62405 Verbena Rd.  
 Joshua Tree, CA 92252  
 Attn: Mark Goodale 760-366-2986

, PERMITTEE

and subject to the following, PERMISSION IS HEREBY GRANTED to:

Enter onto SR-62 right-of-way at Elk Trail in the Town of Yucca Valley, to remove approximately 89' existing AC curb, two existing curb ramps and one existing bus shelter; to install, own and maintain new 6" concrete curb and gutter, 6' wide sidewalk, two curb ramps, 6" thick bus shelter pads, and install one bus shelter as per construction plan and traffic control plan date stamped June 12, 2019 by Caltrans District 8 Encroachment Permits Office, and/or to the satisfaction of the Caltrans Representative.

Notwithstanding General Provision #4, your contractor is required to apply for and obtain an encroachment permit prior to starting work. A deposit of \$ 820 for processing permit application and for inspection, and a copy of payment and performance bonds are required at the time of application.

A pre-job meeting with the assigned Caltrans Representative, Martin Morris, (909) 383-4207, is required at least 7 days prior to start of any work under this permit. Failure to do so may result in permit revocation with no prejudice.

**THIS PERMIT IS NOT A PROPERTY RIGHT AND DOES NOT TRANSFER WITH THE PROPERTY TO A NEW OWNER.**

The following attachments are also included as part of this permit (Check applicable):

- Yes  No General Provisions
- Yes  No Utility Maintenance Provisions
- Yes  No Storm Water Special Provisions
- Yes  No Special Provisions
- Yes  No A Cal-OSHA permit, if required: Permit No. \_\_\_\_\_
- Yes  No As-Built Plans Submittal Route Slip for Locally Advertised Projects
- Yes  No Storm Water Pollution Prevention Plan / Water Pollution Control Plan

In addition to fee, the permittee will be billed actual costs for:

- Yes  No Review
- Yes  No Inspection
- Yes  No Field Work

(if any Caltrans effort expended)

- Yes  No The information in the environmental documentation has been reviewed and considered prior to approval of this permit.

This permit is void unless the work is completed before December 26, 2019

This permit is to be strictly construed and no other work other than specifically mentioned is hereby authorized.

No project work shall be commenced until all the other necessary permits and the environmental clearances have been obtained.

PERMIT ENGINEER: Chien-Hsin Chu  
 COPIES TO:  
 Maintenance: Paradise Valley  
 M. Morris  
 File

APPROVED:

BY:

  
 Michael D. Beauchamp, District Director

  
 RAMAKRISHNA TADI, PHD, P.E., District Permit Engineer

**ADA Notice**

For individuals with sensory disabilities, this document is available in alternate formats. For alternate format information, contact the Forms Management Unit at (916) 445-1233, TTY 711, or write to Records and Forms Management, 1120 N Street, MS-89, Sacramento, CA 95814.

In addition to the attached General Provisions, the following checked special provisions are applicable:

A PRE-JOB MEETING WITH THE ASSIGNED CALTRANS REPRESENTATIVE, Martin Morris, (909)383-4207 AT LEAST 7 DAYS IS REQUIRED PRIOR TO START OF ANY WORK UNDER THIS PERMIT. FAILURE TO DO SO WILL RESULT IN PERMIT CANCELLATION AND RESUBMITTAL MAY BE REQUIRED.

Notwithstanding General Provision #4, your contractor is required to apply for and obtain an encroachment permit prior to starting work. A fee/deposit of \$ 820 for inspection, and \$                      for electrical equipment is required at the time of application.

You are required to submit an approved Storm Water Pollution Prevention Plan (SWPPP) for projects with a cumulative disturbed soil area equal or greater than 1 acre, and an approved Water Pollution Control Program (WPCP) for projects with a disturbed soil area less than 1 acre, unless otherwise required by other agencies (RWQCBs, U.S. Army Corps of Engineers, Department of Fish and Game, etc.).

Upon the expiration of this permit, the Permittee is required to apply for the countywide annual maintenance permit for this new facilities installed under the Permit No.:   .

The Permittee is required to apply for a separate permit to maintain and/or replace in kind of these facilities on each occurrence upon the expiration of this permit.

The Permittee shall provide the stage construction traffic handling plans, work schedule and a list of all sub-contractors to the Department's Representative at the time of the pre-construction meeting or prior to start construction.

All traffic control, signing and striping shall comply with California MUTCD 2014. It is available at: [http://www.dot.ca.gov/hq/traffops/signtech/mutcdsupp/ca\\_mutcd.htm](http://www.dot.ca.gov/hq/traffops/signtech/mutcdsupp/ca_mutcd.htm)

Permittee and his/her contractors shall comply with Department 2018 Standard Specifications, Department 2018 Standard Plans, and all the latest revisions implemented as of this permit issued date, and the project specific special provisions for Oversight Projects and Streamlined Oversight Projects. It is the responsibility of the permittee and his/her contractors to verify with the Department Standard Plans, Standard Specifications, and all the latest revisions as of this permit issued date before ordering any materials for the project within the Department Right-Of-Way. The Department Standard Plans, Standard Specifications, and the Revisions are available at: <http://www.dot.ca.gov/hq/esc/oe/standards.php>

Permittee and/or permittee's authorized contractor/agent are required and responsible to identify the Department's underground electrical systems before performing any excavation work within the right of way.

All personnel shall wear hard hats and orange or lime vests, shirts or jackets as appropriate while on State property.

The Permittee's work shall be subordinated to any operations which the Department may conduct and shall not delay, nor interfere with the Department's Forces or Department's Contractors.

Attention is directed to Standard Specifications Section 7-1.11, Preservation of Property, and Business and Professions Code, Section 8771. The Permittee shall physically inspect the work site and locate survey monuments prior to work commencement. Monuments shall be referenced or reset in accordance with the Business and Professions Code.

Except for installing, maintaining and removing traffic control devices, any work encroaching within 3 feet of the edge of a traffic lane for areas with a posted speed limit below 45mph, or 6 feet of the edge of a traffic lane, for areas with a speed limit posted at 45mph or higher, shall require closing of the adjacent traffic lane. Permittee shall notify the Department's Representative, and obtain approval of, all traffic control, lane closures or detours, at least seven (7) WORKING DAYS prior to setting up of any traffic control.

No lane may be closed or obstructed at any time unless specifically allowed per the encroachment permit, shown in approved traffic control plans, and/or as directed by the Department's Representative.

Traffic control is generally authorized between 9:00 AM and 3:00 PM only on Monday through Thursday and until 1:00 PM on Fridays, excluding holidays except specified in the Permit. Lane closure is not allowed on Saturdays, Sundays and designated holidays. The designated holidays are: January 1st, the third Monday in January, the second and third Mondays in February, March 31, the last Monday in May, July 4th, the first Monday in September, the second Monday in October, November 11th, Thanksgiving Day, the day after Thanksgiving Day, and December 25th. When a fixed holiday falls on Saturday, the preceding Friday shall be designated as holiday.

Should any deviation from these procedures or conditions be observed, all work shall be suspended until satisfactory steps have been taken to ensure compliance.

If time extension is necessary, a request for time extension and the accompanying attachments must be made a minimum of two (2) weeks prior to completion date stated on face of permit. If work has not been started before completion date, the permit will be voided. Failure to comply with rules and regulations stated on permit will jeopardize future permit privileges.

"AS-BUILT" PLANS ARE REQUIRED UPON COMPLETION OF ALL WORK. PLEASE REFER TO THE GENERAL PROVISION TR-0045, ITEM 22 FOR THE "AS-BUILT" REQUIREMENTS. NO FINAL INSPECTION WILL BE PERFORMED UNTIL THE DEPARTMENT IS IN RECEIPT OF "AS-BUILT" PLANS.

No vehicle or equipment shall be stored overnight within the right of way; it shall be removed immediately at the completion of the day's work. Refueling of vehicle or equipment within the right of way is strictly prohibited.

Required traffic control devices shall be installed around fixed objects to warn the motoring public for safety. Personal vehicles of the contractor shall not be parked within freeway right of way.

No materials or waste shall be stockpiled within State right of way.

Except as specifically provided herein, all requirements of the Vehicle Code and other applicable laws must be complied with in all particulars.

When traffic cones or delineators are used to delineate a temporary edge of traffic lane, the line of cones or delineators shall be considered to be the edge of the traffic lane. The permittee shall not reduce the width of the existing lane to less than 10 feet without written approval from the Department's Representative.

Excavations made within the limits of the right of way shall be backfilled and resurfaced to original condition before leaving the work area unless otherwise authorized by the Department's Representative.

All trenches repair shall comply with ENCROACHMENT PERMIT TRENCH DETAIL, TR-0153 or to the satisfaction of the Department's Representative.

Permittee shall be responsible for arranging the services of a qualified traffic control contractor to provide any needed traffic control.

The permittee shall arrange a meeting between his field representative, traffic control contractor, Department's Representative and/or CHP at least two (2) weeks prior to start of any work covered under this permit to arrange date and time of starting work and determine appropriate methods of handling traffic. At least 3 working days notice shall be given to the Caltrans representative and/or the CHP, prior to the meeting to allow time to arrange for attendance.

A copy of this permit, complete with all attachments, shall be kept by permittee/contractor working under this permit and must be shown to the Department Permit Inspector, Department's Representatives, or Law Enforcement Officer, on demand.

The permittee shall be responsible for notifying the appropriate utility companies or underground service alert prior to any excavation work.

The permittee shall notify the California Highway Patrol Area Commander at least 72 hours prior to implementing traffic control.

When the work area encroaches upon a sidewalk, walkway, or crosswalk area, special consideration must be given to pedestrian safety. Protective barricades, fencing, handrails and bridges, together with warning and guidance devices and signs must be utilized so that the passageway for pedestrians, especially blind and other physically handicapped, is safe and well defined and shown on the approved permit plan.

Pedestrian walkways and canopies within State Right of Way shall comply with the requirements of the applicable local agency or of the latest edition of the Uniform Building Code whichever contains the higher standards.

[For City or County projects with utility relocations:]

If existing public or private utilities conflict with the construction PROJECT, PERMITTEE will make necessary arrangements with the owners of such utilities for their protection, relocation, or removal. PERMITTEE shall inspect the protection, relocation, or removal of such facilities. Total costs of such protection, relocation, or removal which STATE or PERMITTEE must legally pay, will be borne by PERMITTEE. If any protection, relocation, or removal of utilities is required, including determination of liability for cost, such work shall be performed in accordance with STATE policy and procedure. PERMITTEE shall require any utility company performing relocation work in the STATE's right-of-way to obtain a State Encroachment Permit before the performance of said relocation work. Any relocated utilities shall be correctly located and identified on the as-built plans.

[For other projects with utility relocations:]

If existing public or private utilities conflict with the construction PROJECT, PERMITTEE will make necessary arrangements with the owners of such utilities for their protection, relocation, or removal. PERMITTEE

PAGE 4: ATTACHED TO AND MADE PART OF PERMIT NO. 08-19-N-BS-0680

shall inspect the protection, relocation, or removal of such facilities. Total costs of such protection, relocation, or removal shall be borne by PERMITTEE in compliance with the terms of the Highway Encroachment Permits, Case Law, Public Utility Regulations, and Property Rights. PERMITTEE shall require any utility company performing relocation work in the STATE's right-of-way to obtain a State Encroachment Permit before the performance of said relocation work. Any relocated utilities shall be correctly located and identified on the as-built plans.

In addition to the attached General Provisions (TR-0045), the following special provisions are also applicable:

1. Advertising displays on bus passenger shelters or benches may not be within 660' (201m) of and visible from any Federal Aid Interstate or Primary highway. Advertising displays shall only be placed at approved passenger loading areas. The advertising displays must not extend beyond the exterior limits of the shelter or bench. Advertising shall not exceed two (2) display panels per shelter or bench.
2. Bus passenger shelters and benches shall be located a minimum of 2' (0.6 m) behind the face of curb, with a minimum of 4' (1.2 m) width of walkway available.
3. All pavement shall be saw cut prior to removal.
4. Pavement markings obliterated shall be replaced in kind by permittee.
5. No telephone installations are authorized by this permit.

PERMIT NO.: 08-19-N-BS-0680

CO/RTE/PM: 08-SBD-62-10.443-VAR

PRECONSTRUCTION MEETING AGREEMENT

I, \_\_\_\_\_, acting as an authorized agent for the permittee, \_\_\_\_\_, do hereby agree to personally accomplish or have another designated person arrange for all involved company representatives to attend a pre-construction meeting with the authorized Department's Representative at \_\_\_\_\_, as specified on this permit. Such meeting must be held two (2) days or more prior to the planned start of the work on this project. The Authorized Department's Representative shall have complete authority to determine whether the permit conditions, either implied or written, have been complied with. The Department's Representative may then allow the permit work to proceed as appropriate. The Pre-construction Meeting Record below must be signed by both the Department's Representative and the permittee before the permit work may start.

I have read and understand the attached General Provisions TR-0045 and other attached provisions of this permit.

This agreement or a copy thereof, must be mailed back to the Department's District 8 Encroachment Permit Office at 464 W. 4th. Street, MS 619, San Bernardino, CA 92401-1400, within three (3) working days prior to the pre-construction meeting. Failure to return this form could delay the release of your bonds. A copy of this document shall be at the job site at all times when work is in progress and failure to do so may result in the suspension of work, as directed by the Department's Representative.

It is the permittee's responsibility to insure that the Department's Representative is notified of work completion and that the attached Completion Notice is mailed to the Department's Permit office.

Signature Date

Print or Type Name

Position or Title

**PRECONSTRUCTION MEETING RECORD**

Department's Representative

Date

Permittee's Representative

Date

Date Work May Begin: \_\_\_\_\_





**1. GENERAL:** The purpose of these Special Provisions is to provide the Permittee with specifications for water pollution control to minimize, prevent, or control the discharge of material into the air, surface waters, groundwater, and storm sewers owned by the State or local agencies. These provisions are not intended to take the place of the Caltrans Water Pollution Control Program (WPCP) for projects where soil disturbance from work activities less than one acre, or work activities of one acre or more subject to the preparation of the Caltrans Storm Water Pollution Prevention Plan (SWPPP) that would require a waste discharge identification number or coverage under the California Construction General Permit (*Order No. 2009-0009-DWQ, NPDES No CAS000002*). The Permittee shall comply with the following Special Provisions and the direction of the State Representative.

**2. NPDES REQUIREMENTS:** The Permittee shall be responsible for full compliance with the Caltrans Storm Water Program and the Caltrans National Pollutant Discharge Elimination System (NPDES) Permit requirements. It is the Permittee's responsibility to install, inspect, and repair or maintain facilities and devices used for water pollution control practices before performing daily work activities. Installation and maintenance responsibilities on the job site include: 1) soil stabilization materials in work areas that are inactive or prior to storm events, 2) water pollution control devices to control sediment and erosion, 3) implementation of spill and leak prevention procedures for chemical and hazardous substances stored on the job site, 4) material storage, 5) stockpile management, 6) waste management, 7) non-stormwater management, 8) water conservation, and 9) illicit connection, illegal discharge detection and reporting. The Permittee shall report to the state representative when discharges enter into receiving waters, adjacent property, drainage systems or when discharges could be a cause or a threat for water pollution. The Permittee shall also control illicit discharges or illegal dumping prior to start of daily work schedule. Copies of written notices or orders from the Regional Water Quality Control Board or other regulatory agency shall be provided to the State representative within 48 hours of reported activity. For additional information on storm water compliance, visit the State Water Resources Control Boards storm water Website at [http://www.waterboards.ca.gov/water\\_issues/programs/stormwater](http://www.waterboards.ca.gov/water_issues/programs/stormwater)

**3. RESPONSIBILITY FOR DEBRIS REMOVAL:** The Permittee shall be responsible for preventing sediment, trash, debris, and other construction waste from entering the street, the storm drains, local creeks, or any other bodies of water.

**4. SPOILS AND RESIDUE:** The Permittee shall vacuum any saw-cut concrete waste material, debris, residue, etc. No spoils, debris, residue, etc. shall be washed into a drainage system.

**5. SWEEPING:** Sweep paved roads at construction entrance and exit locations and surrounding paved areas daily within the job site during: 1) clearing and grubbing, 2) earthwork, 3) trenching, 4) soil disturbance, 5) pavement grinding and/or cutting, and 6) after observing tracking of material onto or off the State property. Keep dust to a minimum during sweeping activities. Use vacuum whenever dust generation is excessive or sediment pickup is ineffective. Roadways or work areas shall not be washed down with water. Street sweeping operations must conform to Section 13 Water Pollution Control of the State of California standard specifications for construction (most current version) <http://www.dot.ca.gov/hq/esc/oe/specifications/SSPs/2010-SSPs/>.

**6. VEHICLES AND EQUIPMENT:** Permittee shall prevent all vehicles, equipment, etc. from leakage or mud tracking onto

roadways. If leaks cannot be repaired immediately, remove the vehicle or equipment from the job site.

**7. MAINTENANCE AND FUELING OF VEHICLES AND EQUIPMENT:** Maintenance and fueling of equipment shall not result in any pollution at the job site. The Permittee shall immediately clean up spills/leaks, and properly dispose of contaminated soil and materials.

**8. CLEANING VEHICLES AND EQUIPMENT:** Limit vehicle and equipment cleaning or washing at the job site except what is necessary to control vehicle tracking or hazardous waste. The Permittee shall clean all equipment within a bermed area or over a drip pan large enough to prevent run-off. No soaps, solvents, degreasers, etc shall be used in State right of way. Any water from this operation shall be collected and disposed of at an appropriate site. Containment berms or dikes shall be used for fueling, washing, maintaining and washing vehicles or equipment in outside areas. Containment must be performed at least 100 feet from concentrated flows of storm water, drainage courses, and storm drain inlets if within a flood plain, otherwise at least 50 feet if outside the floodplain. Keep adequate quantities of absorbent spill-cleanup material and spill kits in the fueling or maintenance area and on fueling trucks.

**9. DIESEL FUELS:** The use of diesel fuel from petroleum or other fossil fuel as a form-oil or solvent is not allowed.

**10. WEATHER CONDITIONS AT WORKSITE:** Any activity that would generate fine particles or dust that could be transported off site by stormwater shall be performed during dry weather.

**11. HOT MIX ASPHALT:** Runoff from washing hot mix asphalt shall not enter into any drainage conveyances.

**12. PROTECTION OF DRAINAGE FACILITIES:** The Permittee shall protect/cover gutters, ditches, drainage courses, and inlets with gravel bags, fiber rolls, State approved fabric filters, etc., to the satisfaction of the State representative during grading, paving, saw-cutting, etc. and materials must conform to Section 13-6.02 Materials for Water Pollution Control of the State of California standard specifications for construction (most current version). No such protection measures shall cause an obstruction to the traveling public. The Permittee shall implement spill and leak prevention procedures for chemicals and hazardous substances stored on the job site in accordance to section 13-4.03B(1-3) Spill Prevention and Control, Water Pollution Control, of the State of California standard specifications for construction (2010 version).

**13. PAINT:** Rinsing of painting equipment and materials is not permitted in state right-of-way. When thoroughly dry, dispose of the following as solid waste: dry latex paint, paint cans, used brushes, rags, gloves, absorbent materials, and drop cloths. Oil based paint sludge and unusable thinner shall be disposed of at an approved hazardous waste site.

**14. CONSTRUCTION MATERIALS:** Stockpile of all construction materials, including, but not limited to; pressure treated wood, asphalt concrete, cold mix asphalt concrete, concrete, grout, cement containing premixes, and mortar, shall conform to section 13-4.03C Material Management (Storage & Stockpiles), Water Pollution Control, of the State of California standard specifications for construction (2010 version).

**15. CONCRETE EQUIPMENT:** Concrete equipment shall be washed in a designated washing area in a way that does not contaminate soil, receiving waters, or storm drain systems.

3/24/17

**16. EXISTING VEGETATION:** Established existing vegetation is the best form of erosion control. Minimize disturbance to existing vegetation. Damaged or removed vegetation shall be replaced as directed by the State Representative.

**17. SOIL DISTURBANCE:** Soil disturbing activities shall be avoided during the wet weather season. If construction activities during wet weather are allowed in your permit, all necessary erosion control and soil stabilization measures shall be implemented in advance of soil disturbing activity.

**18. SLOPE STABILIZATION AND SEDIMENT CONTROL:** Consider a certified expert in Erosion and Sediment control in cases where slopes are disturbed during construction. The Permittee is directed to comply with Section 13.5 Temporary Soil Stabilization and Section 21 Erosion Control of the State of California (2010 version) standard specifications for construction during application of temporary soil stabilization measures to the soil surface. Fiber rolls or silt fences may be required down slope until permanent soil stabilization is established. Remove the accumulated sediment whenever the sediment accumulates to 1/3 of the linear sediment barrier height.

**19. STOCKPILES:** Stockpiles containing aggregate and/or soil shall be stored at least 100 feet from concentrated flows of storm water, drainage courses, and storm drain inlets if within a flood plain, otherwise at least 50 feet if outside the floodplain, and shall be covered and protected with a temporary perimeter sediment barrier. Cold mix stockpiles shall be stored on an impermeable surface and covered with 9mil plastic to prevent contact with water.

**20. DISCOVERY OF CONTAMINATION:** The State Representative shall be notified in case any unusual discoloration, odor, or texture of ground water, is found in excavated material or if abandoned, underground tanks, pipes, or buried debris are encountered.

**21. SANITARY AND SEPTIC WASTE:** Do not bury or discharge wastewater from a sanitary or septic system within the highway. Properly connected sewer facilities are free from leaks. With State Representative approval place portable sanitary facility at least 50 feet away from storm drains, receiving waters, and flow lines. Permittee must comply with local health agency provisions when using an on-site disposal system.

**22. LIQUID WASTE:** Prevent job site liquid waste from entering storm drain systems and receiving waters. Drilling slurries, grease or oil-free waste water or rinse water, dredging, wash water or rinse water running off a surface or other nonstorm water liquids not covered under separate waste water permits shall be held in structurally sound, leak-proof containers, such as portable bins or portable tanks. Store containers at least 50 feet away from moving vehicles and equipment. Liquid waste may require testing to determine hazardous material content prior to disposal.

**23. WATER CONTROL AND CONSERVATION:** Manage water use in a way that will prevent erosion and the discharge of pollutants into storm drain systems and receiving waters. Direct runoff water, including water from water line repair from the job site to areas where it can infiltrate into the ground. Direct water from off-site sources around the job site or from contact with jobsite water.

**24. PILE DRIVING:** Keep spill kits and cleanup materials at pile driving locations. Park pile driving equipment over drip pans,

absorbent pads, or plastic sheeting with absorbent material, and away from storm water run-on when not in use.

**25. DEWATERING:** Dewatering consists of discharging accumulated storm water, groundwater, or surface water from excavations or temporary containment facilities. All dewatering operations shall comply with the latest Caltrans guidelines. Contact State representative for approval of dewatering discharge by infiltration or evaporation, otherwise, any effluent discharged into a permitted storm water system requires approval from the Regional Water Quality Control Board. Prior to the start of dewatering, the Permittee shall provide the State Representative with a dewatering and discharge work plan that complies with section 13-4.01B Submittals, Water Pollution Control, of the State of California standard specifications for construction (2010 version). A copy of the Waste Discharge Permit and a copy of a valid WDID number issued by the Regional Board shall be provided to the State representative.

Included in this package is your  
**Permit & “Customer Service  
Questionnaire”**

Please fill out the questionnaire and return it  
along with the

**“100% Completion Notice”**  
(Only when work is completed)

**Three simple ways to submit your  
“Customer Service Questionnaire”:**

1. Give it to the “Inspector” at final inspection
2. Mail it to:

*Department of Transportation  
Encroachment Permits  
464 W. 4<sup>th</sup> Street, 6<sup>th</sup> Floor, MS 619  
San Bernardino, CA 92401-1400*

3. Fax to: (909) 383-6370

**Your input is greatly appreciated!!!**



PERMIT NUMBER
---------------

Dear Customer,

Our goal is to provide the best service possible to our customers. Please take a few minutes to complete this questionnaire. Your comments will enable us to see how we are doing overall and any areas which may need improvement.

**PLEASE TELL US HOW WE'RE DOING**

INSIDE THE OFFICE	EXCELLENT	VERY GOOD	GOOD	POOR
Staff courteous and helpful	<input type="checkbox"/>	<input type="checkbox"/>	<input type="checkbox"/>	<input type="checkbox"/>
Staff quick and efficient	<input type="checkbox"/>	<input type="checkbox"/>	<input type="checkbox"/>	<input type="checkbox"/>
Explanations and instructions clear	<input type="checkbox"/>	<input type="checkbox"/>	<input type="checkbox"/>	<input type="checkbox"/>

**TELEPHONE ANSWERING**

Timely response	<input type="checkbox"/>	<input type="checkbox"/>	<input type="checkbox"/>	<input type="checkbox"/>
Receiving information or answers	<input type="checkbox"/>	<input type="checkbox"/>	<input type="checkbox"/>	<input type="checkbox"/>

**INSPECTION**

Inspector courteous and helpful	<input type="checkbox"/>	<input type="checkbox"/>	<input type="checkbox"/>	<input type="checkbox"/>
Pre-construction meeting set and held in a timely manner	<input type="checkbox"/>	<input type="checkbox"/>	<input type="checkbox"/>	<input type="checkbox"/>
Inspector at job site frequently	<input type="checkbox"/>	<input type="checkbox"/>	<input type="checkbox"/>	<input type="checkbox"/>
Inspector able to answer questions and deal with problems	<input type="checkbox"/>	<input type="checkbox"/>	<input type="checkbox"/>	<input type="checkbox"/>

**OVERALL PERFORMANCE**

What would you say is our overall performance?	<input type="checkbox"/>	<input type="checkbox"/>	<input type="checkbox"/>	<input type="checkbox"/>
--	--------------------------	--------------------------	--------------------------	--------------------------

Is there a staff person you would like to commend?	STAFF'S NAME:
--	---------------

COMMENTS:

NAME (Optional)	BUSINESS PHONE NUMBER	DATE
-----------------	-----------------------	------